

RADIO NEWS

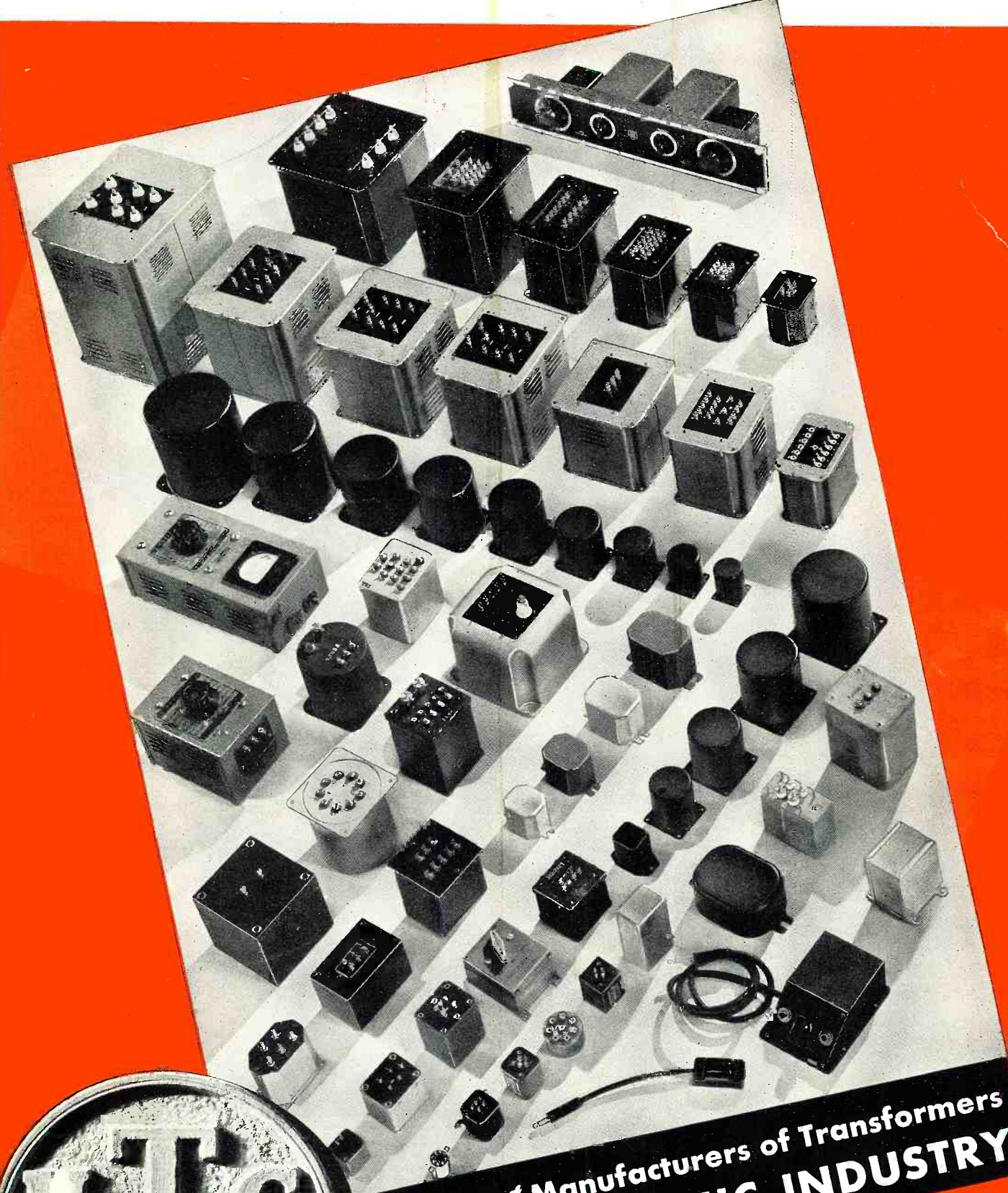

MARCH
1944
25c
in Canada 30c



Foremost Manufacturers of Transformers
to the **ELECTRONIC INDUSTRY**

United Transformer Co.

150 VARICK STREET • NEW YORK 13, N. Y.
EXPORT DIVISION: 13 EAST 40th STREET, NEW YORK 16, N. Y., CABLES: "ARLAB"

FREE Lesson in Radio

Gives You A Real Start Toward Understanding These Subjects

With 31 Photos, Sketches, Radio Drawings

- How superheterodyne circuits work
- How to remove tubes, tube shields
- Three reasons why Radio tubes fail
- Electrodynamic loudspeaker:
 - How it works
 - Replacing damaged cone
 - Recentering voice coil
 - Remedies for open field coil
- Output transformer construction, repair
- Gang tuning condenser:
 - Construction of rotor, stator
 - How capacity varies
 - Restraining dial cord
 - Straightening bent rotor plates

- I.F. transformers—
 - What they do, repair hints
- How to locate defective soldered joints

GETTING ACQUAINTED WITH RECEIVER SERVICING

- Inside story of carbon resistors
- Paper, electrolytic, mica, trimmer condensers
- How condensers become shorted, leaky
- Antenna, oscillator coil facts
- Power transformer: construction, possible troubles
- Installing power cord
- Troubles of combination volume control, on-off switch
- Tone controls
- Dial lamp connections
- Receiver servicing technique:
 - Checking performance
 - Testing tubes
 - Circuit disturbance test
- Isolating defective stage
- Locating defective part



See For Yourself How I Train You at Home to BE A RADIO TECHNICIAN

More Radio Technicians and Operators Now Make \$50 a Week Than Ever Before

I will send you a sample Lesson, "Getting Acquainted with Receiver Servicing," to show you how practical it is to train for Radio at home in spare time. It's a valuable lesson. Study it—keep it—use it—without obligation! And with this Lesson I'll send my 64-page illustrated book, "Win Rich Rewards in Radio." It describes many fascinating jobs Radio offers, explains how N. R. I. trains you at home for good pay in Radio!

Big Demand Now for Well-Trained Radio Technicians, Operators

There's a big shortage today of capable Radio Technicians and Operators. Fixing Radios pays better now than for years. With new Radios out of production, fixing old sets, which were formerly traded in, adds greatly to the normal number of servicing jobs.

Be Ready to Cash In on Good Pay Jobs Coming in Television, Electronics

Broadcasting Stations, Aviation and Police Radio, and other Radio branches are scrambling for Operators and Technicians. Radio Manufacturers, now working on Government orders for Radio equipment, employ trained men. The Government too needs hundreds of competent civilian and enlisted Radio men and women. And think of the NEW jobs that Television, Electronics and other Radio developments will open after the war.

I Trained These Men

 <p>\$200 a Month "For several years I have been in business for myself making around \$200 a month. I have N.R.I. to thank for my start." AR-Texas.</p> <p>LIE J. FROEHNER, 300 W. Texas Ave., Goose Creek, Texas.</p> <p>First Lieutenant "I cannot divulge any information as to my work but N.R.I. training is coming in mighty handy." RICHARD W. ANDERSON, (Address omitted for military reasons.)</p>	 <p>\$5 to \$10 Week in Spare Time "I am engaged in spare time Radio work. I average from \$5 to \$10 a week." THEODORE K. DURRE, 400 E. Horsesham, Pa.</p> <p>Chief Operator Broadcasting Station "Before I completed your lessons I obtained my Radio Operator's license and joined Station WMTC where I am now Chief Operator." H. O. L. S. F. HAYES, 827 W. Madison St., Lapeer, Michigan.</p>
--	---

Many Beginners Soon Make \$5, \$10 a Week EXTRA in Spare Time

The moment you enroll for my Course I start sending you EXTRA MONEY JOB SHEETS that show you how to earn EXTRA money fixing Radios. Many make \$5, \$10 a week EXTRA in spare time while still learning. I send you SIX big bits of real Radio parts. You LEARN Radio fundamentals from my lessons—PRACTICE what you learn by building typical circuits like those illustrated on this page—PROVE what you learn by interesting tests on the circuits you build.

EXTRA PAY IN ARMY, NAVY, TOO

Men likely to go into military service, soldiers, sailors, marines, should mail the Coupon now! Learning Radio helps Service men get extra rank, extra prestige, more interesting duties, MUCH HIGHER PAY. Also, prepares for good Radio jobs.

Mail Coupon for Free Lesson and Book

The opportunity the war has given beginners to get started in Radio may never be repeated. So take the first step at once. Get my FREE Lesson and 64-page, illustrated book. No obligation—no salesman will call. Just mail coupon in an envelope or paste it on a penny postal.—J. E. SMITH, President, Dept. 4CR, National Radio Institute, Washington 9, D. C.

You Build These and Many Other Radio Circuits With Kits I Supply

By the time you've conducted 60 sets of Experiments with Radio Parts I supply—have made hundreds of measurements and adjustments—you'll have valuable PRACTICAL experience.

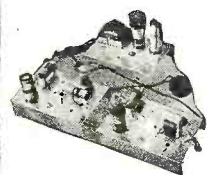

You build this SUPERHETERODYNE CIRCUIT containing a pre-selector oscillator-mixer-first detector, i.f. stage, diode-detector-a.v.c. stage and audio stage. It will bring in local and distant stations. Get the thrill of learning at home evenings in spare time while you put the set through fascinating tests!

You build this MEASURING INSTRUMENT yourself early in the Course, useful for practical Radio work on neighborhood Radios to pick up EXTRA spare time money. It is a vacuum tube multimeter, measures A.C., D.C. and R.F. volts, D.C. currents, resistance, Receiver Output.



Building this A. M. SIGNAL GENERATOR will give you valuable experience. Provides amplitude modulated signals for test and experimental purposes.

GOOD FOR BOTH 64 PAGE BOOK SAMPLE LESSON FREE

J. E. SMITH, President, Dept. 4CR, National Radio Institute, Washington 9, D. C.

Mail me FREE, without obligation, Sample Lesson and 64-page book, "Win Rich Rewards in Radio." (No salesman will call. Write plainly.)

Name Age

Address

City State 4FR

Have you a friend or pal who is interested in Radio? Write his name and address below and I'll send him my book, "Win Rich Rewards in Radio." We will not mention your name unless you request it.

Name

Address

City State 4CRA



C O N T E N T S

FEATURES

Future Automatic Air Traffic Control Devices.....*Glen A. Gilbert* 21
 Postwar Two-Way Radio Systems.....*Samuel Freedman* 24
 Electro-Optics*Albert A. Shurkus* 26
 Nomographic Evaluation of Complex Numbers..... 29
 Simple Square-Wave Generator.....*Rufus P. Turner* 30
 Broadcast Stations as Frequency Standards.....*Guy Dexter* 32
 Mine Locators*Connery Chappell* 34
 Panoramic Reception.....*C. T. Read, W9AA* 35
 Jungle Broadcast*George B. Hill* 38
 Electronic Industry 44
 Postwar Television*Phil Glanzer* 46

DEPARTMENTS

For the Record 8
 Spot Radio News.....*Lewis Winner* 10
 QTC 40
 Book Review 40
 Theory and Application of U.H.F., Part 3.....*Milton S. Kiver* 41
 Manufacturers' Literature 46
 Practical Radio Course, Part 21.....*Alfred A. Ghirardi* 47
 What's New in Radio..... 49
 The Saga of the Vacuum Tube, Part 10.....*Gerald F. J. Tyne* 50

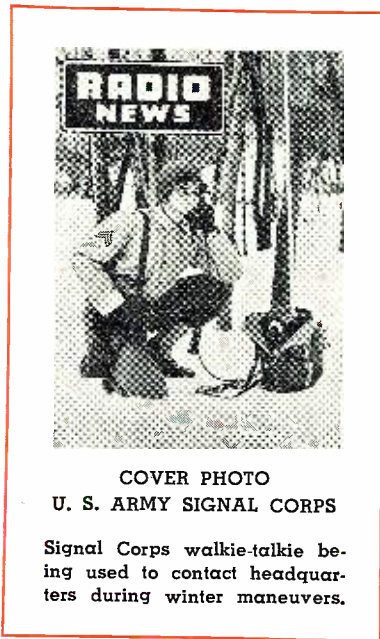

COVER PHOTO
U. S. ARMY SIGNAL CORPS

Signal Corps walkie-talkie being used to contact headquarters during winter maneuvers.

WILLIAM B. ZIFF
Publisher

B. G. DAVIS
Editor

C. R. TIGHE
Ass't to Publisher

OLIVER READ, W9ETI
Managing Editor

WM. A. STOCKLIN
Associate Editor

R. A. WHITEMAN
Technical Editor

JOE MARTY, JR.
Field Editor

J. M. ECKERT
Assistant Editor

R. B. FRANK, W9JU
(on leave)

E. H. SEHNERT
Chief Draftsman

K. R. PORTER
War Correspondent

W. E. SMITH
War Photographer

S. L. CAHN
Advertising Mgr.

GEORGE BERNER
Advertising Director

HERMAN R. BOLLIN
Art Director

H. G. STRONG
Circulation Director

Copyright, 1944
ZIFF-DAVIS PUBLISHING COMPANY
 Editorial Offices: 540 N. Michigan Ave., Chicago 11, Ill.
 Member of the Audit Bureau of Circulations

RADIO NEWS is published monthly by the Ziff-Davis Publishing Company at 540 N. Michigan Ave., Chicago, Ill. New York Office, 270 Madison Ave., Washington, D. C., Office, Earle Bldg., Special Washington Representative, Col. Harold E. Hartney, Occidental Hotel, London Editorial Representative, A. Spenser Allberry. Subscription Rates: In U. S. \$3.00 (12 issues), single copies, 25 cents; in South and Central America and U. S. Possessions, \$3.00 (12 issues); in Canada \$3.50 (12 issues), single copies 30 cents; in British Empire, \$4.00 (12 issues); all other foreign countries \$6.00 (12 issues). Subscribers should allow at least 2 weeks for change of address. All communications about subscriptions should be addressed to: Director of Circulation, 540 N. Michigan Ave., Chicago, Ill. Entered as second class matter March 9, 1938, at the Post Office, Chicago, Illinois, under the Act of March 3, 1879. Entered as second class matter at the Post Office Department, Ottawa, Canada. Contributors should retain a copy of contributions. All submitted material must contain return postage. Contributions will be handled with reasonable care, but this magazine assumes no responsibility for their safety. Accepted material is subject to whatever adaptations, and revisions, including "by-line" changes, necessary to meet requirements. Payment covers all authors, contributors or contestants rights, title, and interest in and to the material accepted and will be made at our current rates upon acceptance. All photos and drawings will be considered as part of material purchased.



"HOGARTH SAYS HE CAN'T FEEL
REALLY LOST WHEN HE HAS
HIS ECHOPHONE EC-1 ALONG"

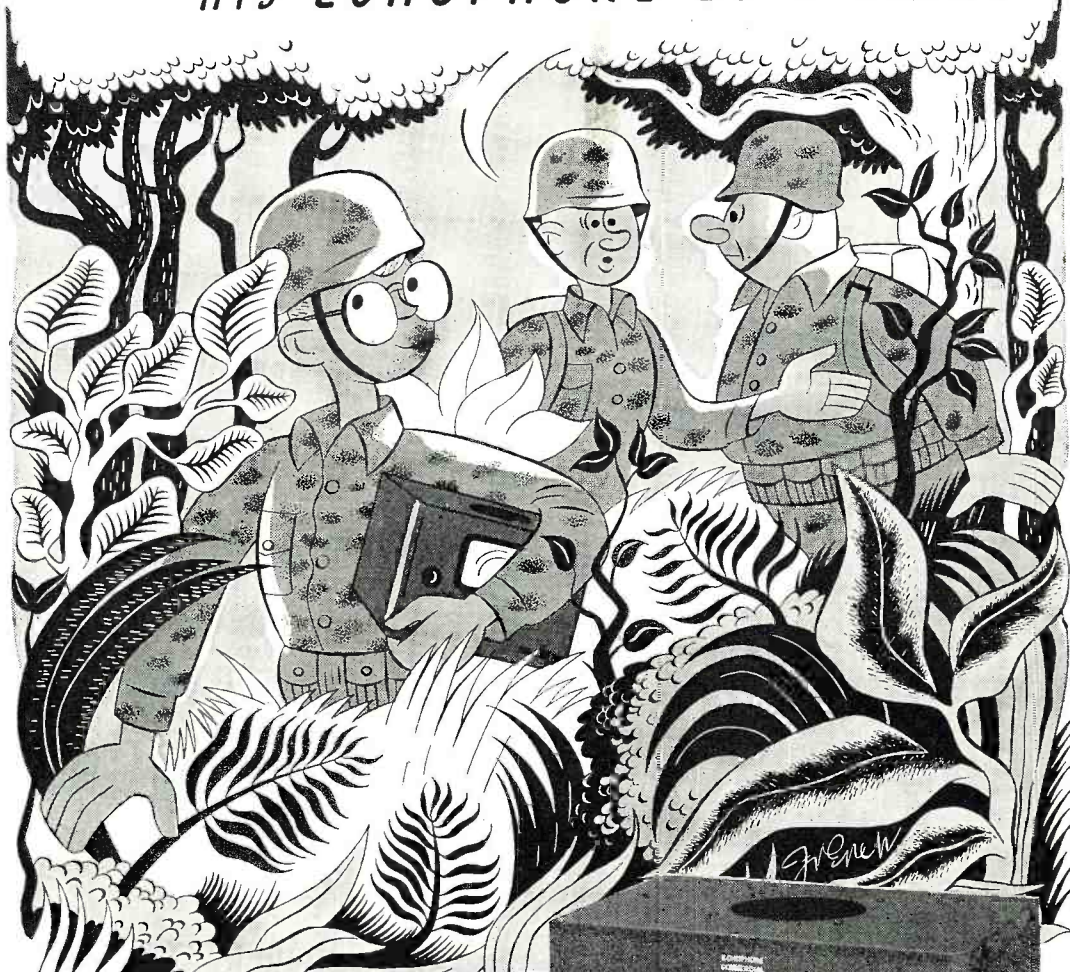

Echophone Model EC-1

(Illustrated) a compact communications receiver with every necessary feature for good reception. Covers from 550 kc. to 30 mc. on three bands. Electrical band-spread on all bands. Beat frequency oscillator. Six tubes. Self-contained speaker. Operates on 115-125 volts AC or DC.



ECHOPHONE RADIO CO., 201 EAST 26th ST., CHICAGO, ILLINOIS

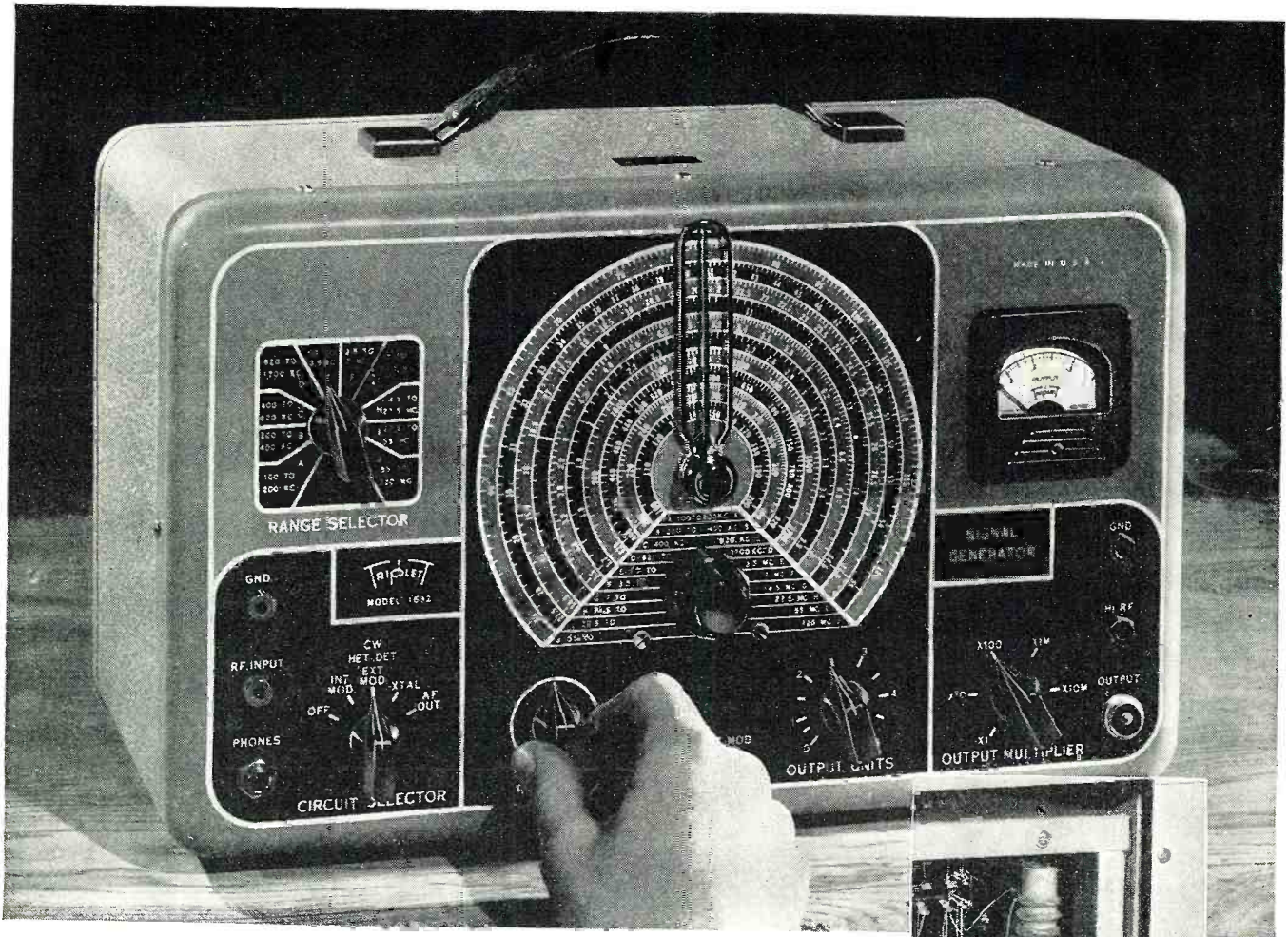

MODEL NO. 1632

Signal Generator

CONTINUOUS COVERAGE—100 KC. TO 120 MC. • ALL FREQUENCIES FUNDAMENTALS

A complete wide-range Signal Generator in keeping with the broader requirements of today's testing. Model 1632 offers accuracy and stability, beyond anything heretofore demanded in the test field, plus the new high frequencies for frequency modulated and television receivers, required for post-war servicing. Top-quality engineering and construction throughout in keeping with the pledge of satisfaction represented by the familiar Triplet trademark.

Of course today's production of this and other models go for war needs, but you will find the complete Triplet line the answer to your problems when you add to your post-war equipment.

Triplet

ELECTRICAL
BLUFFTON



INSTRUMENT CO.
OHIO ***

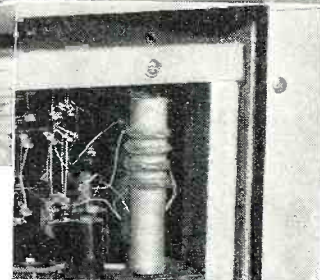

- Triple shielding throughout, Steel outer case, steel inner case, plus copper plating.

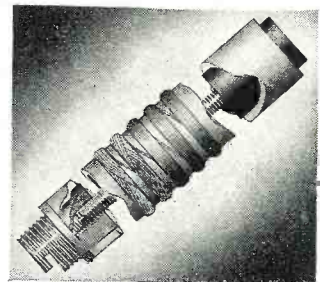

- All coils permeability tuned. Litz wire wound impregnated against humidity with "high-Q" cement.

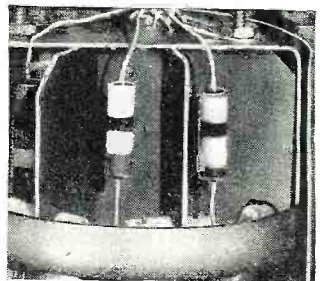

- Note sections individually shielded with pure copper. Entire unit encased in aluminum shield.

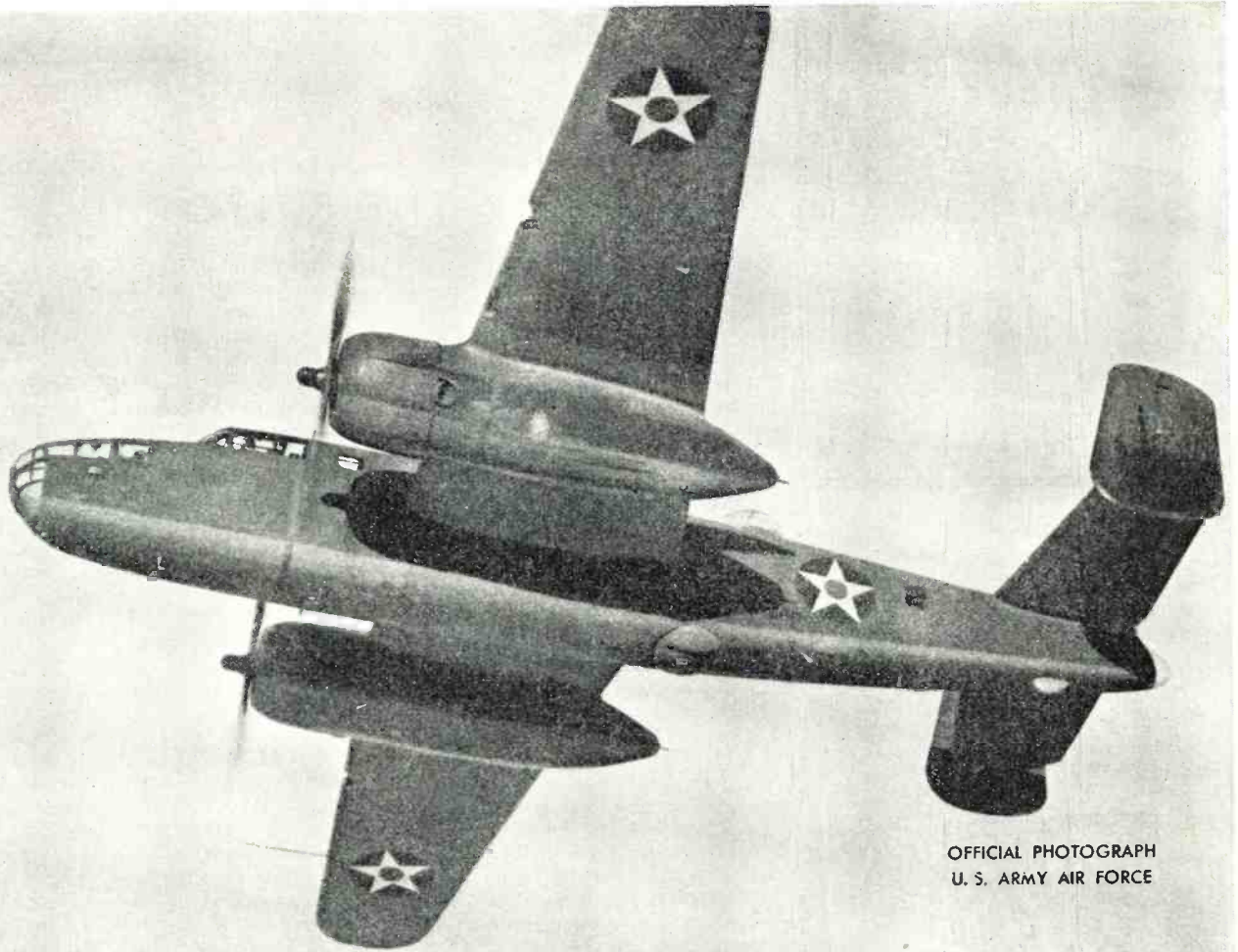

OFFICIAL PHOTOGRAPH
U. S. ARMY AIR FORCE

A LONG WAY FROM HOME!

● Boring into the sunset, this Mitchell has a rendezvous with danger. Armed to the teeth, and freighted with destruction, she will fight her way in to the "target for tonight" and she will fight her way home again. She and her sisters have a deadly job to do, and radio will help them do it.

Ground stations around the world depend heavily on the HRO receiver for dependable communications with aircraft.



NATIONAL COMPANY, INC.
MALDEN, MASS.

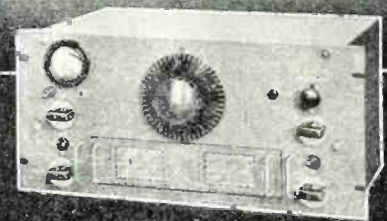

RADIO EQUIPMENT HINTS

SYLVANIA SERVICEMAN SERVICE

by
FRANK FAX



"RADIO EQUIPMENT HINTS" describes testing equipment so important to every radio man's service bench. Hints on how to use this equipment will save your time in tracing and locating receiver troubles.

There are 59 pages of clear information from radio tube headquarters. The volume is liberally illustrated with photographs, circuits and graphs.

Read over the subjects in the Table of Contents, reproduced below:

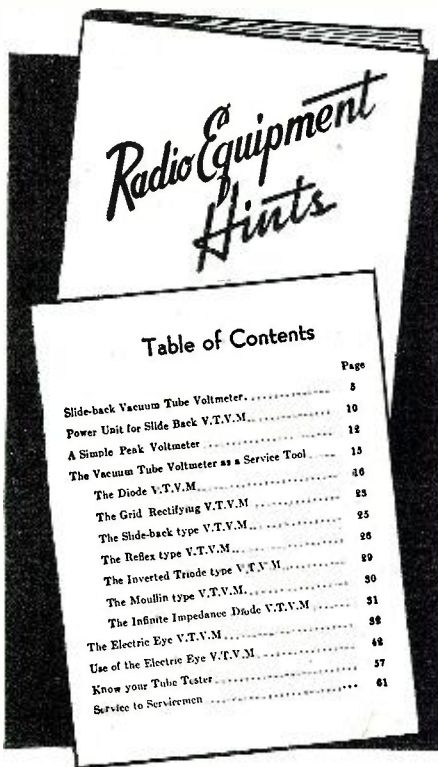

This is the second of the new Sylvania "Hints" series.

"Radio Equipment Hints" is FREE. If your jobber does not have copies, write to: FRANK FAX, SYLVANIA, EMPORIUM, PA.

SYLVANIA

ELECTRIC PRODUCTS INC.
RADIO DIVISION • EMPORIUM, PA.

For the Record

BY THE EDITOR

WE ARE firmly convinced that radio can, and will, become a valuable asset to the safety and communications problems of the nation's railroads. Recent news stories indicate a growing interest in this matter on the part of members of Congress, railroad executives and other leaders concerned with the problems of safety and convenience in travel and transportation.

Thoughts of application of radio for this purpose are not new. But the actual application is. Ships and planes are using radio communications for practically all their dispatching and communications. In their case the technical difficulties were relatively simple because interference of terrain and ferrous metals were not generally present. Neither were they troubled with the presence of power lines, signal bridges and other adjacent metallic structures.

But, we are coming into a new era of radio knowledge—a knowledge that has been learned "the hard way." Wars are disastrous and deplorable, but the technical knowledge gained in this war may afford us the opportunity in coming years to actually save as many lives and as much material as the war cost. Our industry's experience in developing two-way radio equipment for tanks and submarines should enable us to lick the majority of the technical problems present in "rail radio."

Many authorities believe that this should be a postwar job—a job that should be delayed because immediate war production goals must be met. But we believe that the problem is an immediate one—one that should receive attention without delay because it is vital that we alleviate as much as possible the loss of material and manpower resulting from the recent epidemic of rail disasters.

We appreciate that rail transportation enjoys the highest safety ratio of any public utility, but we sincerely believe that the use of radio as an additional safety device will enable them to actually increase the safety ratio to a point where it approaches perfection.

WHILE talking to the plant superintendent at our printers the other day—we were told that the February Signal Corps issue of RADIO NEWS was the largest magazine ever printed by them. In fact, as far as we can determine, it is the largest issue ever published in the radio field. Our subscribers received a real bonus with its record-breaking contents of 454 pages.

While we are compelled to use a

lighter paper stock—the same as all consumers—we did manage to cover all important branches of the activities of the Signal Corps in a single issue. Now that we've caught our breath—we recall the many trips that were made to gather photographs, to arrange and plan editorial material and to study the vast organization that is the Signal Corps. We found the Officers and other personnel most cooperative in helping to bring to our readers the war-time responsibilities of the Corps and the manufacturers who supply the material they require to "do a job." It is a matter of record that the Signal Corps of today is one of the most efficient organizations of any military branch. We know you will agree!

WE WISH to thank the readers of our Radio-Electronic ENGINEERING and Radio-Electronic MANUFACTURER editions for their many letters of commendation. Plans are being made to even further increase the editorial scope of these inserts. The nation's leading technical authors and industrial leaders will continue to present material of greatest value to the readers of these special editions of RADIO NEWS.

TUBE manufacturing programs for the postwar era indicate that most of the tubes made will be of miniature style. Development and design appear to have progressed to the point where it is entirely practical, from an engineering and economical standpoint, to produce the miniature type tubes for most applications. Engineers say that miniature tube techniques have been so improved that an amazing degree of efficiency can be expected from the most complex multi-element tube. To augment the general adoption of miniature tubes are the new compact dry batteries with shelf life four times greater than pre-war units.

RADIO played an important role in our surprise landing on the west coast of Italy on January 22. It was a most stunning and hazardous operation—one that required complete coordination of all forces. Mobile radio units, Handie-talkies, and mine-detectors were in service immediately following the landings. Our troops are depending on us to supply them with ample supplies of communications equipment. They're getting it—the finest and most versatile of any made for military use!

O. R.

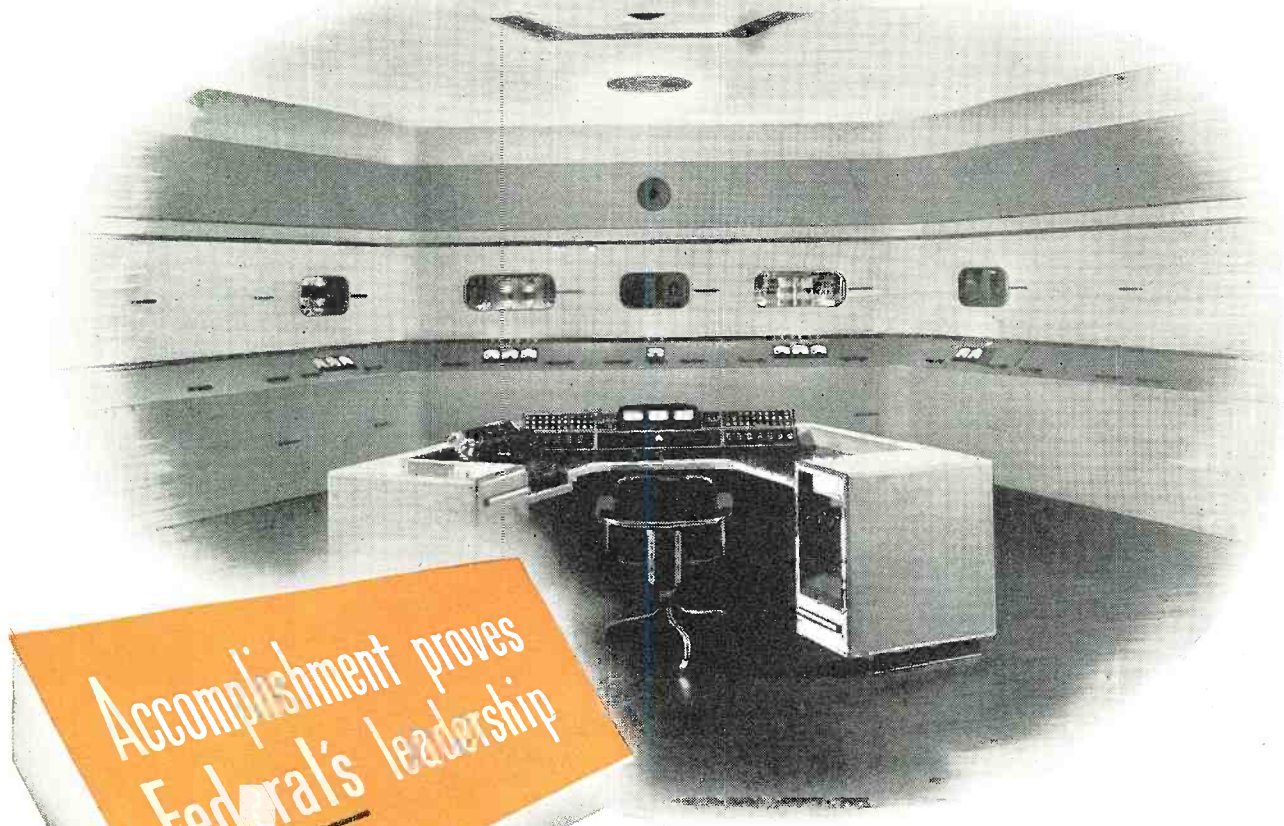

Accomplishment proves
Federal's leadership

When the curtain goes up on the approaching post-war era, Federal does not propose to perform sleight-of-hand in producing a startling fantasia in broadcast equipment.

But Federal, which built WABC, the 50 Kilo-watt key station of the Columbia Broadcasting System and the most modern transmitter in the country, will produce then, as it will discuss now, up-to-the-minute equipment of even greater power to meet individual needs.

Federal's long experience in building transmitters, in both high frequency and standard broadcast ranges, assures equipment that will measure to the highest standards.

Federal's scientific talent, which includes the world's best technical minds, assures equipment that will embody good engineering practices and proved refinements in design.

Federal invites you to discuss your ideas and its facilities for developing transmitting equipment to your particular requirements.

Most of the leading broadcast stations are equipped with Federal transmitting and rectifying tubes — known for their quality and high standard. Use Federal tubes — built with the ultimate of care and workmanship for satisfactory performance.



Federal Telephone and Radio Corporation

COMMUNICATION PRODUCTS DIVISION



Newark, N. J.

Designed for



Application

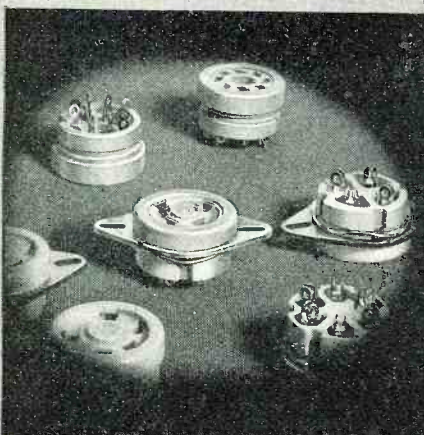

TUBE SOCKETS

Designed for Application

MODERN SOCKETS for MODERN TUBES! Long Flashover path to chassis permits use with transmitting tubes, 866 rectifiers, etc. Long leakage path between contacts. Contacts are type proven by hundreds of millions already in government, commercial and broadcast service, to be extremely dependable. Sockets may be mounted either with or without metal flange. Mounts in standard size chassis hole. All types have barrier between contacts and chassis. All but octal also have barriers between individual contacts in addition.

**JAMES MILLEN
MFG. CO., INC.**

MAIN OFFICE AND FACTORY

MALDEN

MASSACHUSETTS



By **LEWIS WINNER**

RADIO NEWS Washington Correspondent

Presenting latest information on the Radio Industry.

YEAR END REPORTS FROM INDUSTRY AND BROADCAST STATIONS

reveal some mighty interesting facts on the progress achieved on our home and war fronts.

In industry, for instance, plastics played quite a major role. Developments of the year included the impregnating of various types of cloth and paper with plastic resins to produce plastic material that was quite rugged and light in weight. And no expensive tools are necessary to produce the finished products. Interesting plastic parts produced during the year included antenna housings, loud speakers, a variety of components, chassis, and so on. Quartz crystals were also among highlight radio features of the year. An interesting development provided for the application of silver coatings directly to the faces of crystals to prevent frequency changes. This development was of particular assistance in equipment designed for mobile use where the rapid movement was ordinarily responsible for frequency changes of the quartz. The silver coating also permitted the soldering of fine wire, thus facilitating the making of connections.

The transmission of voice over power circuits also rose in popularity during the past year. Developments provided for extremely reliable operation with transmitters having output powers of as low as 3 watts. Transmission over these lines also provided for control of electrical devices, heretofore a project for scores of maintenance engineers.

In broadcasting, transoceanic transmission was intensely active. Over a score of stations were on the air continuously sending out millions of words to all corners of the world. Short-wave listening stations on these shores recorded over a hundred-million words of foreign short-wave broadcasts. Dozens of foreign news reporters reviewed these broadcasts at the rate of over a hundred-thousand words a day. This required translation from as many as fifteen languages.

Frequency modulation was quite active during the year, too. The larger stations maintained operating schedules of up to forty hours weekly. This year that schedule will undoubtedly be doubled in many instances.

Although broadcast stations were required to operate with reduced personnel and limited material for repair, they nevertheless offered service

that was favorable with records of station operation in normal times. For the combined service delays amounted to approximately only one-tenth of one per cent throughout the entire year. This is certainly a notable record, and a tribute to the resourcefulness and perseverance of our engineers, technicians and executive personnel.

THE CONTINUED NEED FOR RADIO equipment for the war effort in substantially vast quantities, precludes the possibility of civilian production in 1944. This was revealed by Bond Geddes, RMA general manager, at the recent RMA mid-winter conference in Chicago. He said that even if Germany should collapse, the needs for electronic equipment in the Pacific area are so great that there would be no plant capacity for civilian goods. Officials at the conference said that government contracts for 1944 call for approximately 50% more volume than in 1943.

Mr. Geddes also pointed out that reconversion will come gradually. He said that government control of manpower, materials and prices is inevitable. However, he explained, the radio industry is in a better position to convert than those engaged in heavier industry.

He emphasized that the price range of future receivers constitutes quite a problem, and will require close control. It is entirely possible, he explained, that government pressure will hold down both production and distribution costs to prevent runaway prices.

RMA president Paul V. Galvin explained that the tremendous growth of the industry from a one-billion dollar business in 1942 to a four-billion dollar affair in 1943 should not be taken as a normal business condition. He said that a healthy percentage of this demand will undoubtedly disappear when peace is declared. We must therefore, he said, be ready to adjust ourselves to the many complex problems that will undoubtedly face the industry. He felt certain that although this adjustment problem was a giant one, we will be able to take it in our stride and solve it without too much grief.

Some interesting sidelights on post-war conditions were also presented recently by FCC chairman James L. Fly and FCC engineer E. K. Jett. They implied, for instance, that standard

RADIO NEWS

Keeping Sea Lanes **FREE** Lanes

More amazing than fiction are the dashing exploits of PT boats. In a war to keep free the sea lanes of the world, these combat vessels streak into action and unleash a group attack that's packed with power and punch. One reason they maneuver so successfully: the lanes of communication are kept free. Vital radio messages from boat to boat are protected against noisy local interference.

In climates tropical or polar, Solar noise-suppression systems absorb static right where it starts—at generators, motors, windshield wipers, contacts and other local sources. Solar Capacitors and Elim-O-Stats, as components of such systems, also protect others of our fighters. Men talking from plane to plane, from jeep to jeep and from tank to tank transmit and receive commands without the lost syllables that might mean lost lives. Solar engineers, pioneers in capacitor manufacture, draw on an unusually rich radio experience and uninterrupted electronic research. In days to come, their war-won knowledge will be valuable in meeting postwar communication needs, just as it is now available for military and naval demands. Solar Manufacturing Corp., 285 Madison Ave., New York 17, N. Y.

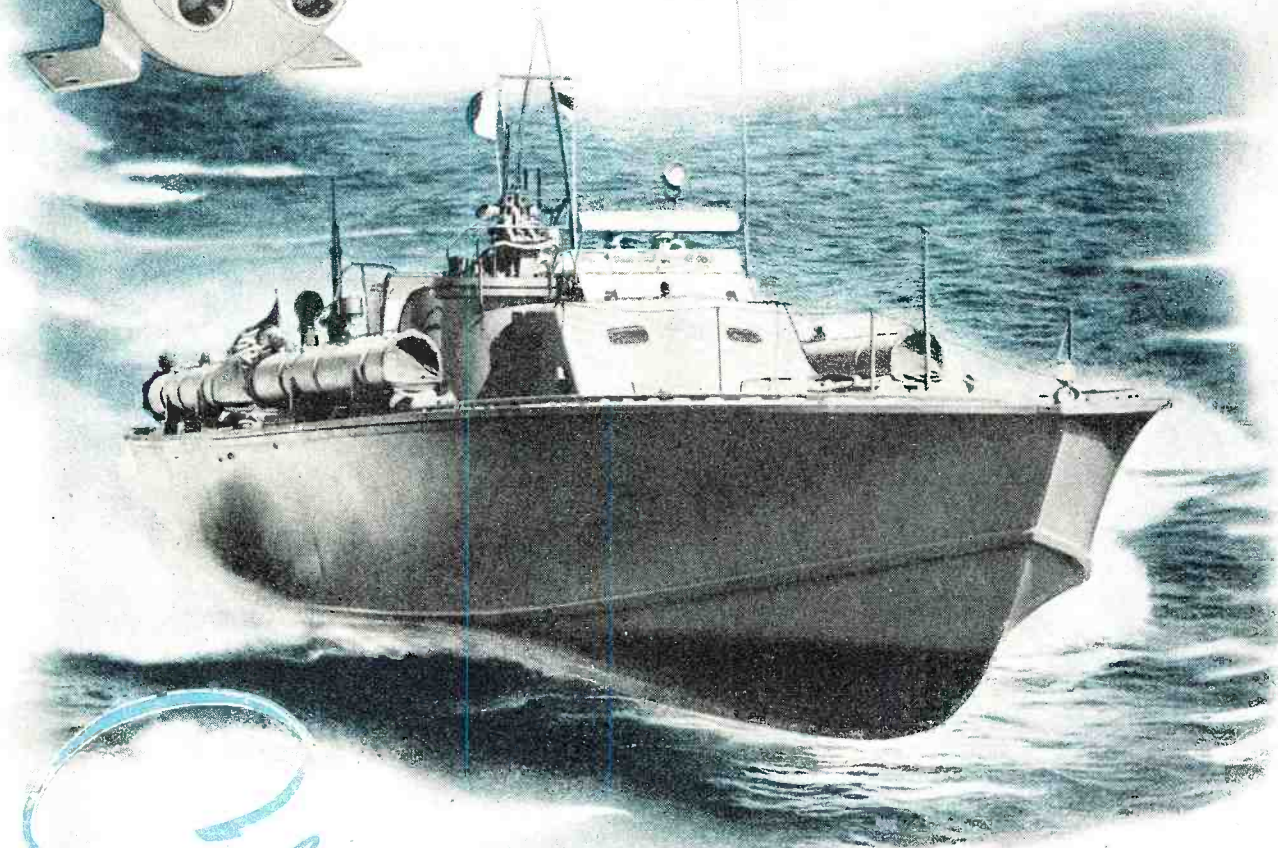
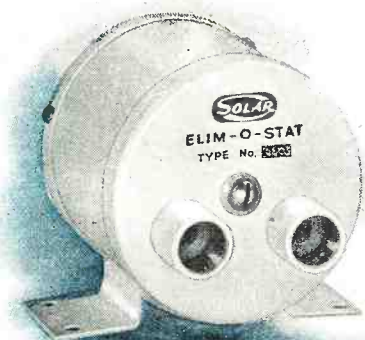

Solar 

ELIM-O-STATS



CAPACITORS AND RADIO NOISE-SUPPRESSION FILTERS

March, 1944

11



SPINTITES ARE REAL SPEED UP TOOLS. This is the WRENCH that works like a SCREW DRIVER

Standard sizes for Hexagon nuts or headed screws . . . special SPINTITES for square or knurled nuts. Handles are either fixed or chuck type SPEED-UP design by makers of WALDEN WORCESTER WRENCHES



STEVENS WALDEN, INC.
465 SHREWSBURY STREET
WORCESTER, MASSACHUSETTS

broadcasting will continue to be used in view of the sixty-million receivers now in homes designed to receive this type of transmission. In addition, they said the primary service is quite good. However, they pointed out, frequency modulation will become an important medium and slowly but surely rise towards great popularity. Their comments on television receivers were quite interesting. As they see it, the many new developments may destroy the usefulness of the television receivers now in service.

They predicted that most of the postwar receivers will provide for standard broadcast, frequency modulation and television reception, and at comparatively moderate prices.

THE SECOND BIRTHDAY of one of the war's outstanding scientific agreements, the British-American Patent Interchange Agreements, was celebrated on January 1st. This agreement has provided for an exchange of patent rights, plans, processes, drawings, designs and technical information between British and American manufacturers on many projects in which radio has been featured. Of course, the agreement which runs for the duration of the war, is confined to manufacturing products essential to it. When the war is over, the patent rights will be returned to their respective owners. Under provisions of the Lend-Lease Act, property interests in the postwar use of all kinds of industrial information are being properly safeguarded.

The agreement provides for the contractor who wishes to use a certain patent, to file his request for this patent through a contracting officer or the technical representative of the service or agency with whom he has made his war contracts. Then a simple requisition is prepared and forwarded to the British representatives.

This agreement was formally signed between the governments of the United Kingdom and Northern Ireland and this country on August 24, 1942. However, it was effectively put into operation on January 1, 1942. Full details on directions and regulations appear in the War Department Procurement regulations, paragraphs 1109-1111 (available from Headquarters, Army Service Forces, War Dept., Washington 25, D. C.) and Navy Procurement directives, paragraphs 14001-14021, inclusive (available from the Office of the Undersecretary of the Navy, Navy Department, Washington 25, D. C.). Copies of the agreement itself are available from the State Department, Washington 25, D. C.

Unfortunately, the products produced as a result of this unusual agreement cannot be described at the present time. However, a host of remarkable radio products have come off the production bench as a result of this agreement . . . projects that we hope to be able to describe soon. In the meanwhile we can say that these projects have contributed materially

to the winning of the war. And that's important enough for the present.

ROMMEL'S NEMESIS GOES ON DISPLAY TOUR. WAC Sergeant Mary Jane MacGuire and William J. Halligan, president, Hallicrafters, Inc., Chicago, inspect the display model of



the Army Signal Corps' famous mobile radio unit, the Hallicrafter SCR-299, part of the Signal Corps Production Incentive exhibit now on tour of war plants making Signal Corps equipment.

This complete receiving and broadcasting unit, which carries its own power and measures 29 feet from front bumper to trailer, is credited with establishing and maintaining communications with fast moving Allied troops in the North African campaign and elsewhere.

TUBES HAVE COME BACK TO LIFE AGAIN in Washington . . . at least in one part of Washington . . . the WPB part. For the Radio and Radar Division of WPB has officially approved of a program calling for the production of at least four and a half-million critical types of tubes, in the first quarter of 1944. But the Navy may prevent the entire program from swinging into full effect. Naval officials have stated that they are quite upset by this authorization of WPB for non-military tube production. They say that they are not getting all the tubes they need for their communication equipment. It appears to be the same situation that arose when the WPB released those 576,613 Philips' tubes only to have the Navy step in and claim that they should have first claim on these tubes. Thus far, it appears as if the Navy may take approximately half of this allotment.

The need for tubes by the military is acknowledged, but the civilian requirements are essential, too. It is thus generally believed that most of this allotment, which by the way takes care of but 50% of the industry requirements, will probably be produced and distributed.

The WPB program included particular production emphasis on nine hard-to-get tubes. These are the 12SA7, 12SQ7, 12SK7, 50L6, 35Z5, 35L6, 1H5, 1A7, and the 80. These and other critical types will bear the familiar "MR" stamp identifying them

HERE IS YOUR SUCCESS CHANCE

BE A

RADIO-ELECTRONIC TECHNICIAN!

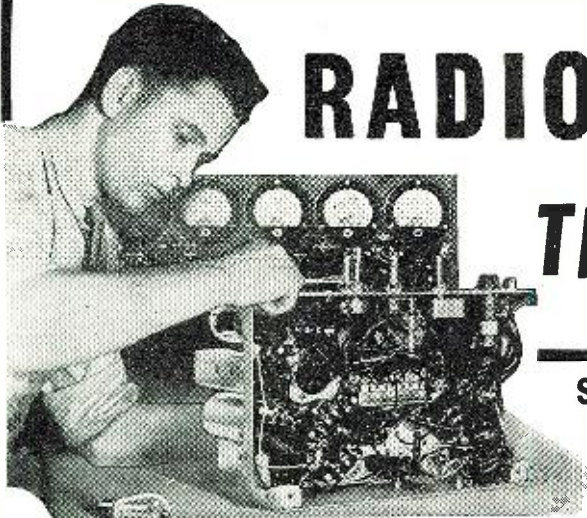

**SPRAYBERRY TRAINS YOU
QUICKLY FOR WAR
AND PEACETIME WORK**

**IF YOU REMAIN A
CIVILIAN OR ENTER
MILITARY SERVICE . . .
Radio Training Will
Enhance Your Future!
• READ THESE LETTERS.**

One Job Nets About \$26.00
"Since last week I fixed 7 radios, all good-paying jobs and right now I am working on an amplifier system. This job alone will net me about \$26.00. As long as my work keeps coming in this way, I have only one word to say and that is "Thanks to my Sprayberry training" and I am not afraid to boast about it."—ADRIEN BENJAMIN, North Grosvenordale, Conn.

**Sprayberry Graduate Wins
Out in Army Test**

"Since I completed your elegant Course in Radio I have been drafted into the Army and put into the Signal Corps. I had to compete to get the job I now hold and as a result of my training with you, I made the best grade and got the job. The point I am driving at is if it hadn't been for your thorough course in Radio I would probably be peeling potatoes now. I recommend your training to all because it is written in language that the average layman can understand."—ARCH PLUMMER, JR., Fort Meade, Md.

**Student Makes \$15.00 to \$20.00
A Week in Spare Time**

"After starting your Course I began doing minor radio service jobs and I want to say that I have been flooded with work. So much so that I have had to neglect my lessons. I want to say your training has done a great deal for me. I am making \$15.00 to \$20.00 a week in spare time. Even so, I'm going to go back to my studies and finish the Course."—SANFORD J. CHICOINE, Whitley, Ontario, Canada.

**You Do Practice-Giving Experiments
with Real Equipment**

The offer I make you here is the opportunity of a lifetime. It's your big chance to get ready for a wonderful future in the swiftly expanding field of Radio-Electronics INCLUDING Radio, Television, Frequency Modulation, and Industrial Electronics. Be wise! NOW is the time to start. No previous experience is necessary. The Sprayberry course is short, intensive, and interesting. It starts right at the beginning of Radio. You can't get lost. It gets the various subjects across in such a clear, simple way that you understand and remember.

**You Get a Dual-Purpose
Radio Set**

I supply you with Radio Parts which you use to gain pre-experience in Repair work. These same Parts are used for testing and for Signal Tracing, etc. I make it easy for you to learn Radio Set Repair and Installation Work . . . by practical, proved, time tested methods. I teach you how to install and repair Electronic Equipment. Your success is my full responsibility.



**Prepares You for a Business
of Your Own . . . or
Good Radio Jobs**

My training will give you the broad fundamental principles so necessary as a background no matter what branch of Radio you wish to specialize in. Soon you'll be qualified for a good paying job in one of the nation's Radio plants doing war work OR a business of your own. If you enter the Army, Navy, or Marines, my training will help you win higher rating and better pay. Let me prove what Sprayberry training can do for you.

JUST OFF THE PRESS!

**"How to Test and Repair Radio
Sets Without Meters"**

Developed in the Sprayberry laboratory, this instructive volume tells about an amazingly simple, yet efficient method for Radio troubleshooting and repair without use of regular equipment made scarce due to war. Send for this free book now while the supply lasts and along with it, I will send you another big free book describing my Radio-Electronic training. Mail coupon.

**YOURS FREE
THESE TWO
VALUABLE BOOKS!**

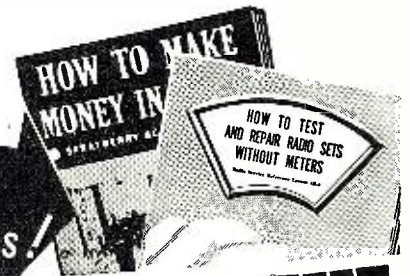

SPRAYBERRY ACADEMY OF RADIO
F. L. Sprayberry, Pres.
Box 500WC
Pueblo, Colorado.

Please rush my FREE copies of "HOW TO TEST AND REPAIR RADIO SETS WITHOUT METERS" and "HOW TO MAKE MONEY IN RADIO."

Name Age

Address

City State

Tear off this coupon, mail in envelope or paste on penny postcard.

NOW! BECOME A MONEY-MAKING RADIO SPECIALIST





Throat Microphones

For Aircraft Inter-Communication systems and radio telephone applications. These microphones open an entirely new field for industrial communications, allowing the wearer to make use of both hands without hampering his other movements. Ideal for use in noisy surroundings where communications must be made by use of headphones.

Model T-30 with CD-318 extension cord and switch, for U. S. Army Radio circuits, now available to priority users through local radio jobbers.

Write for Catalogue No. 961

UNIVERSAL MICROPHONE CO., LTD.

INGLEWOOD, CALIFORNIA

CANADIAN DIV: 560 KING ST. WEST, TORONTO 2
FOREIGN DIV: 301 CLAY, SAN FRANCISCO 11, CAL.

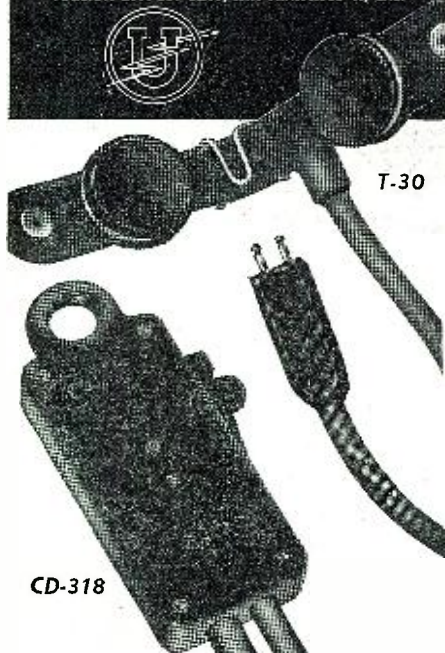

as having been produced for maintenance, repair and operating supply purposes only. These tubes will not be available for rated orders, and should therefore remain in civilian channels.

This new program is unlike the previous statements of policy. That is, up to now, WPB has implied that one and a half-million tubes a month have been redirected to replacement channels. While every attempt was made to adhere to this policy, distribution problems did arise. However, under the new ruling, which triples the previous policy allotment, the tubes will reach the consumer.

According to present schedules it appears as if a good percentage of these tubes should be appearing in the local shops at about the time this column will appear.

In Canada, M. C. Lowe, the Administrator of Electrical Apparatus, Equipment and Supplies, has indicated that tubes for civilian use will probably not be available until after April 1st. He said that a shortage still exists on many types. However, he hopes that after April 1st a substantial quantity of about 125 different types of commercial tubes may be coming off the production line.

ACKNOWLEDGMENT OF RADIO'S usefulness on trains was made recently by the telephone and telegraph section of the Association of American Railroads maintenance and operations department. Acting in response to accumulated public comment that the installation of radiotelephony might have prevented some of the recent wrecks, this section of the Railroad Association has placed a request for an immediate examination of the public safety possibilities of radio on moving trains, before the RTPB. W. R. G. Baker, chairman of the RTPB, is expected to supply a prompt reply to this requested examination.

Members of the industry have shown keen interest in this proposal. William J. Halligan, Hallicrafters president, said that the radio industry's engineers, if given the opportunity, can make radiotelephone dispatching entirely practical. One solution, he said, might be in the use of carrier-current transmission over telegraph or power lines. He cited that railroad passengers of the future should be able to use radiotelephone systems for regular telephone purposes. Today however, he said, the immediate importance of radio on trains would be to augment telegraph dispatching, block systems and other safety equipment now in use to stamp out rail disasters.

UNUSUAL INTEREST IN RECORDING SYSTEMS using wire, tape and film has prevailed throughout the country during the past few weeks. Apparently, many manufacturers and engineers have become aware of the importance of "packaged voice and music," using, how-

ever, other than the disc media. Most of the instruments shown are developments and improvements of old and recently developed techniques; a few employ radically new principles. All of the producers, however, have undertaken their projects with nine major features in mind. These are: (1) playing-time length, (2) compactness of machine and recorded material, (3) cost of equipment, (4) operational cost, (5) simplicity, (6) durability of apparatus and recorded material, (7) maintenance, (8) flexibility and (9) reproduction quality.

Demonstrations have shown that the devices now available do provide many of the necessary features, but none with all the requisites has appeared as yet. Whether the ideal combination will appear soon, is up to not only the engineer, but the chemist and metallurgical expert who provide the tape, film or wire.

Methods used by the systems demonstrated included multi-grooved cellophane or film (using needle embossed and engraved grooves), multi-channel film (for photocell operations), emulsion base film (recorded with needle and played back through photocell) and steel wire or tape. Extremely thin discs capable of a multiple of tracks have also been shown.

Some of the systems provide up to eight hours of playing time service, without much attention. Applications of these various systems are indeed numerous. Increased interest will probably prompt not only many other developments, but effective improvements in the apparatus that has been demonstrated.

CECIL L. SLY, vice president and sales manager of the Universal Microphone Co., Inglewood, Cal., is authority for the statement that he is of the opinion that tomorrow's microphones in a post-war world will be marketed to a public eager and anxious to know the why and how of microphone operation. They will want to know the technicalities of the precision instrument and how it works. "This," he avers, "will largely be because so many former ham operators and potential ones, too, are now in communication corps of the Armed Forces. They will not be content to buy something that looks like a microphone. Instead, they will want to see what's cookin', and most manufacturers will increase their number of technical bulletins, blueprints, diagrams and instruction sheets to meet the new trend in consumer buying."



FLYING BLIND BY RADIO became more than a phrase to Aviation Cadet R. D. Seale recently. Three-

(Continued on page 96)

NEW PLANT

steps up ARHCO production

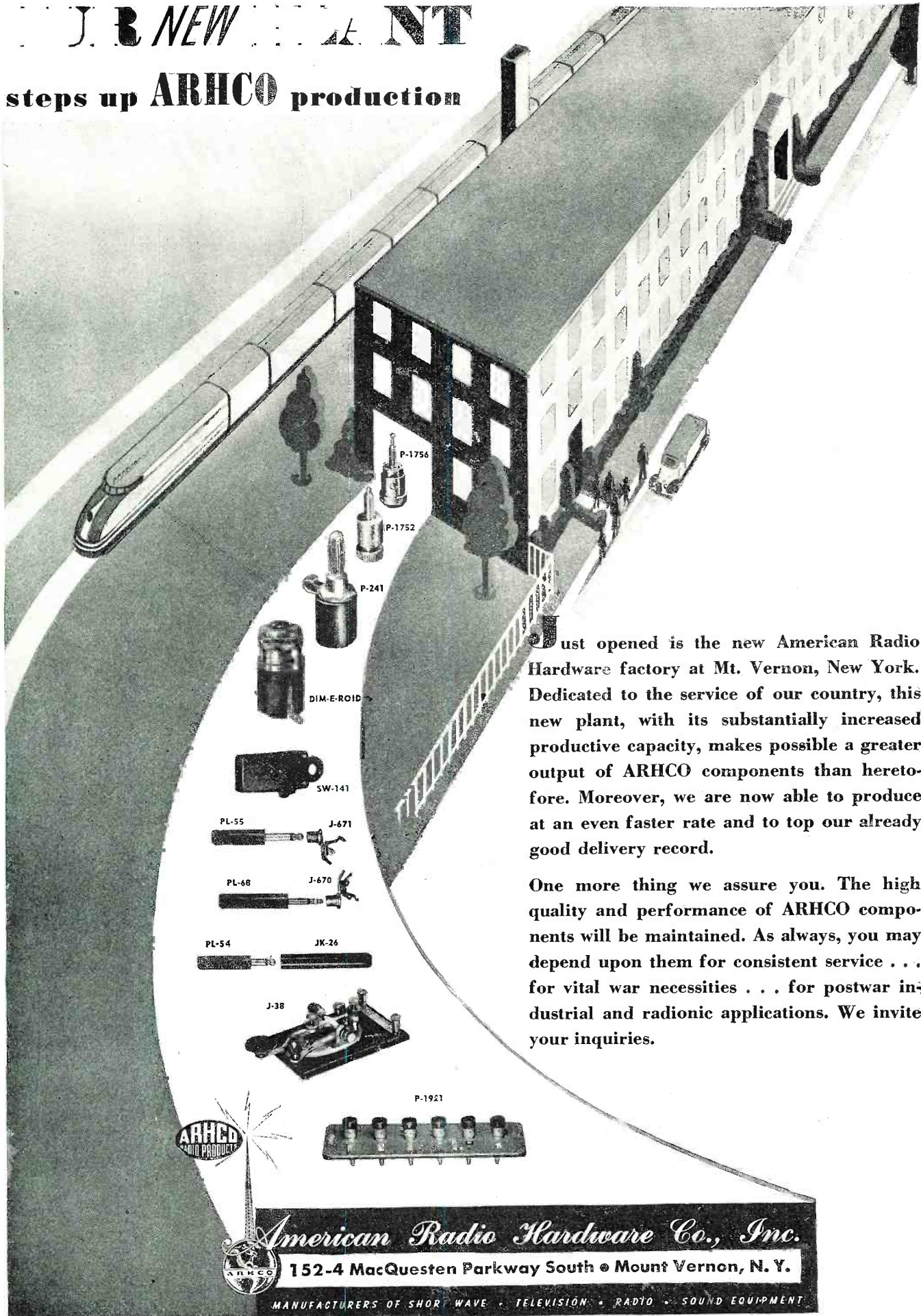

Just opened is the new American Radio Hardware factory at Mt. Vernon, New York. Dedicated to the service of our country, this new plant, with its substantially increased productive capacity, makes possible a greater output of ARHCO components than heretofore. Moreover, we are now able to produce at an even faster rate and to top our already good delivery record.

One more thing we assure you. The high quality and performance of ARHCO components will be maintained. As always, you may depend upon them for consistent service . . . for vital war necessities . . . for postwar industrial and radionic applications. We invite your inquiries.



American Radio Hardware Co., Inc.

152-4 MacQuesten Parkway South • Mount Vernon, N. Y.

MANUFACTURERS OF SHORT WAVE • TELEVISION • RADIO • SOUND EQUIPMENT

Famous Signatures

George Washington

Abraham Lincoln

Thomas Jefferson

John Hancock

Benjamin Franklin

Woodrow Wilson

Theodore Roosevelt

Thomas A. Edison



Jensen

Manufacturers and Designers of Fine Acoustic Equipment

This was the familiar chant of radio technicians when they tested transmitting, receiving and amplifying equipment. It has been replaced by the vicious bark of the guns on an M-5 tank as radio guides it into action. For tomorrow's radios are being conceived and tested in today's battles. And from this vital, concentrated experience is emerging a new conception that FADA will interpret in terms of tonal faithfulness, beauty and lasting durability in its peacetime radios.

Testing-1-2-3-4---

PLACE YOUR FAITH IN THE

FADA Radio

OF THE FUTURE

Famous Since Broadcasting Began!

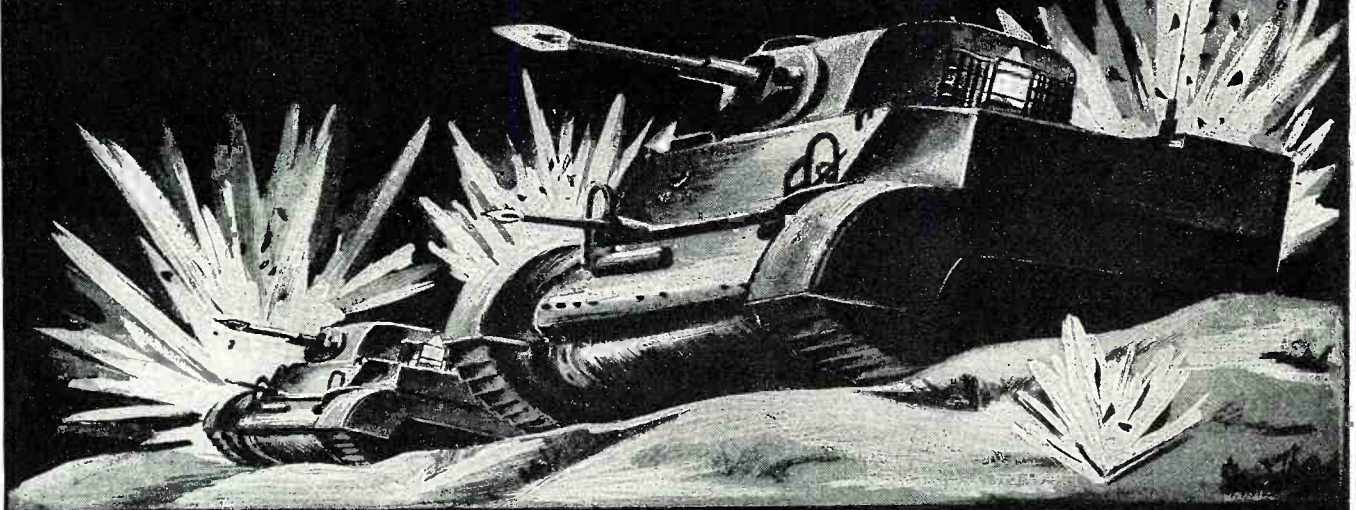

FADA RADIO AND ELECTRIC COMPANY, INC., LONG ISLAND CITY, N. Y.

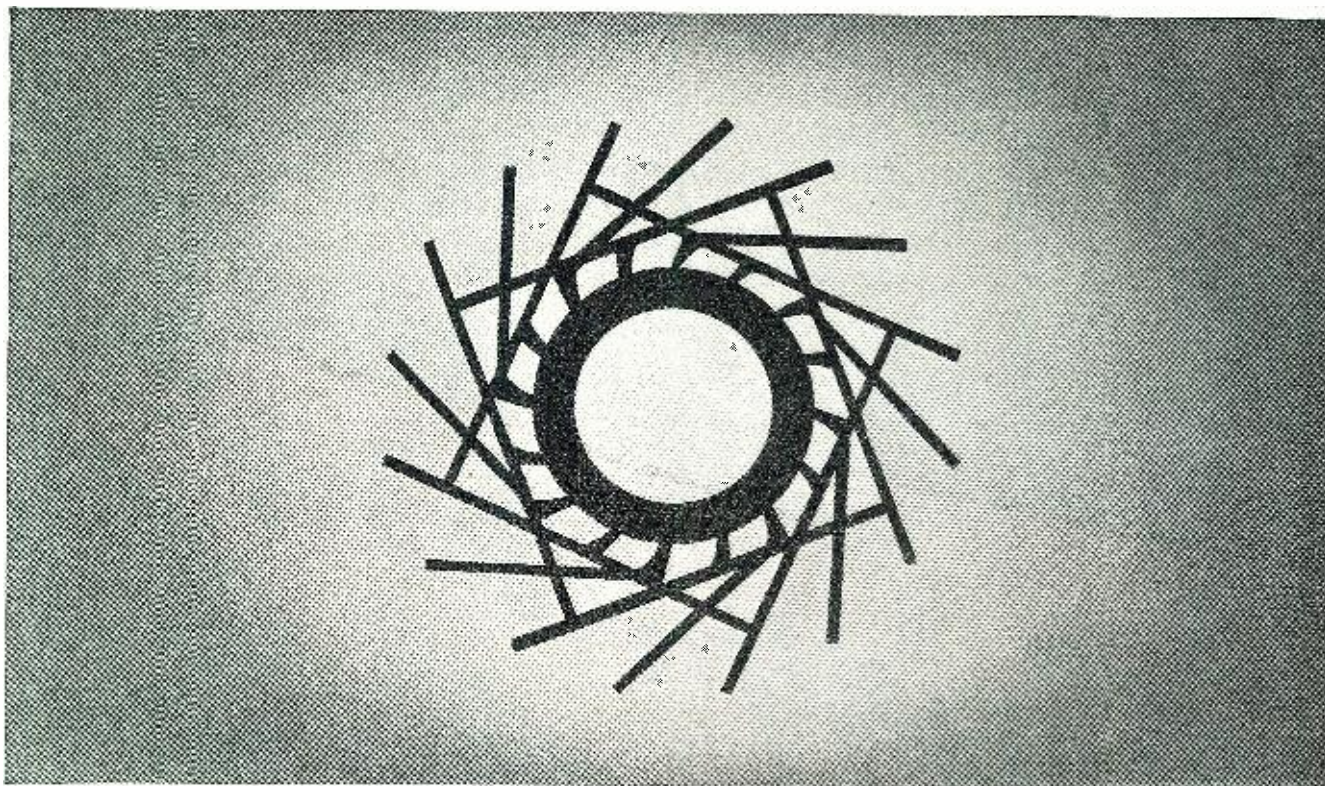

American Airlines tangent airport plan for New York City from "Airports and Air Traffic Control" by Glen A. Gilbert, Chief Air Traffic Control Division, C.A.A.

The Shape of Things to Come . . .

In air transportation especially, the pattern of the future will not be the pattern of the past. No other field holds the prospect of greater advancement nor offers fuller opportunity for sound development.

In things which have made air travel safe and efficient—radio range beacons, markers, communication transmitters and receivers, airport traffic controls—RADIO RECEPTOR, as a pioneer, has contributed its full share of development, and will continue to lead in design and manufacture.

To "the shape of things to come" in aeronautical radio, RADIO RECEPTOR will bring more than 20 years of practical experience. These have been years of successful accomplishment in pre-war aviation radio equipment plus outstanding developments born of the present conflict.

Our non-technical booklet, "HIGHWAYS OF THE AIR," explains the importance of radio to aviation. It will be sent to you upon request. Address Desk R.N.-3

"Although an airway may be loosely defined as a designated route for aircraft plying from airdrome to airdrome, it cannot really be said to exist on a practical scale without airways communications, airdrome traffic control, and radio navigational aids. These are the three components furnished, over some 70,000 miles of foreign military airways, by the Army Airways Communications System Wing."—An excerpt from "The Army Airways Communications System," by Lt. W. Fawcett, Jr., Headquarters, AACCS.



*For Meritorious Service
on the Production Front*

Radio Receptor Co.

INCORPORATED

251 WEST 19th STREET

NEW YORK 11, N. Y.



★ **SINCE 1922 IN RADIO AND ELECTRONICS** ★

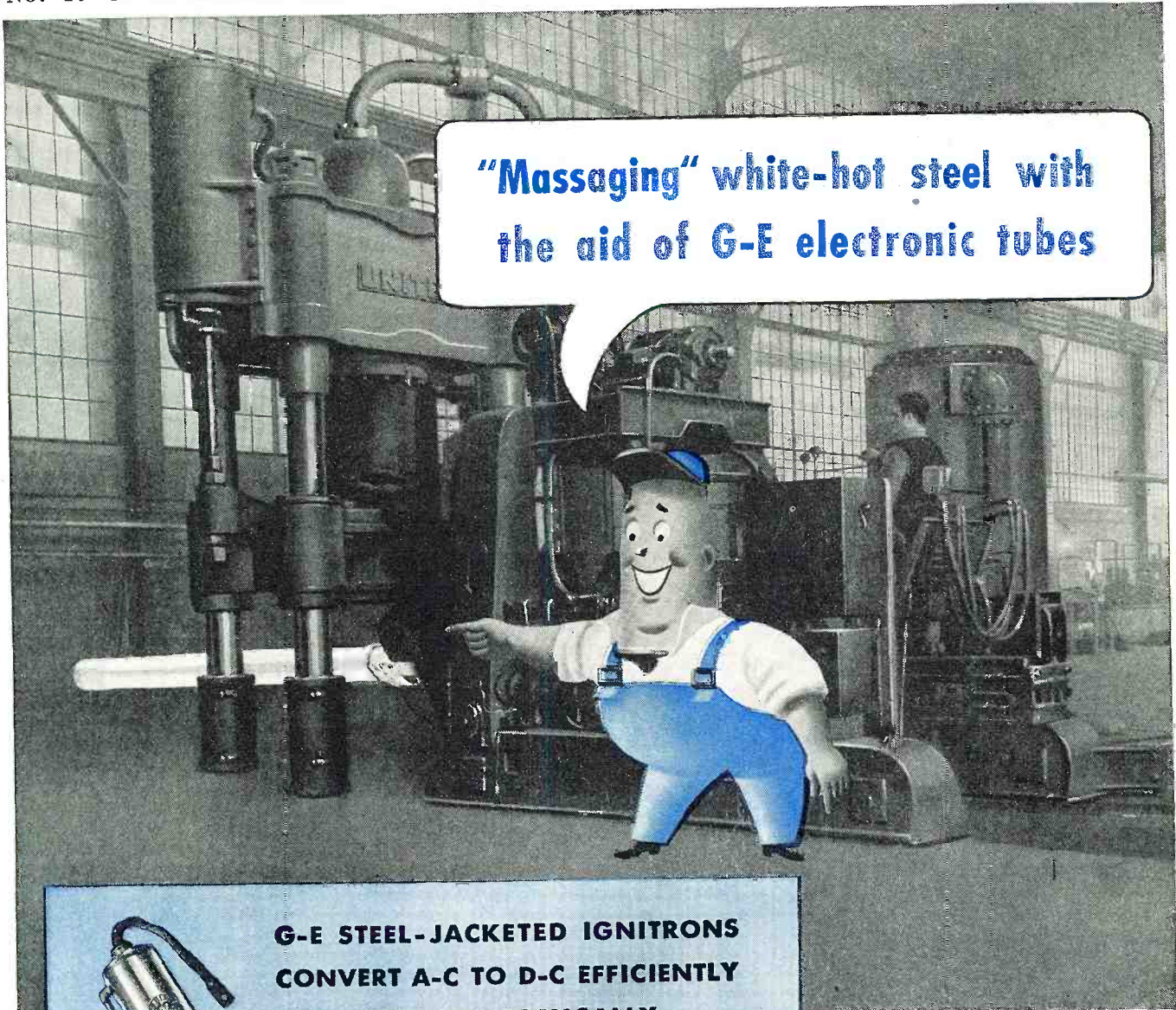

"Massaging" white-hot steel with the aid of G-E electronic tubes



**G-E STEEL-JACKETED IGNITRONS
CONVERT A-C TO D-C EFFICIENTLY
AND ECONOMICALLY**

HERE'S an eight-inch billet getting a "massage" that will reduce its square waistline and shape it into a roughly streamlined gun-barrel. The manipulator which feeds the billet under the hammer — back and forth, round and round — requires D-C power for this precision operation. Sturdy G-E sealed ignitrons supply the power.

These steel-jacketed electronic tubes have no moving parts, are quiet in operation; over-all efficiency is high and practically constant over the entire load range. Available in ratings from 20 amp to 200 amp, they convert A-C into D-C economically and reliably.

Rectifiers using the G-E sealed ignitrons for D-C power at 250 volts or more generally will have about the same installed cost, but lower operating costs than a motor generator set. *Their use permits D-C power to be economically applied to "production spots" where D-C motor drives are essential even though you have an A-C power distribution system throughout the plant.*

The steel-jacketed ignitron is only one of a complete line of G-E electronic tubes now working for industry on innumerable jobs and many kinds of machinery. It is the purpose of the

G-E electronic tube engineers to aid any manufacturer of electronic devices in the application of tubes. Through its nation-wide distributing system, General Electric is also prepared to supply users of electronic devices with replacement tubes.

"HOW ELECTRONIC TUBES WORK"

THIS BOOKLET will be mailed to you *without charge*. Its 24 pages are interestingly illustrated and written in easily understood language. Shows typical electronic tubes and their applications. Address *Electronics Department, General Electric, Schenectady, N. Y.*

• Tune in "The World Today" and hear the news direct from the men who see it happen, every evening except Sunday at 6:45 E.W.T. over CBS. On Sunday listen to the G-E "All Girl Orchestra" at 10 P.M. E.W.T. over NBC.

G.E. HAS MADE MORE BASIC ELECTRONIC TUBE DEVELOPMENTS THAN ANY OTHER MANUFACTURER



162-C2

HAMMARLUND RADIO

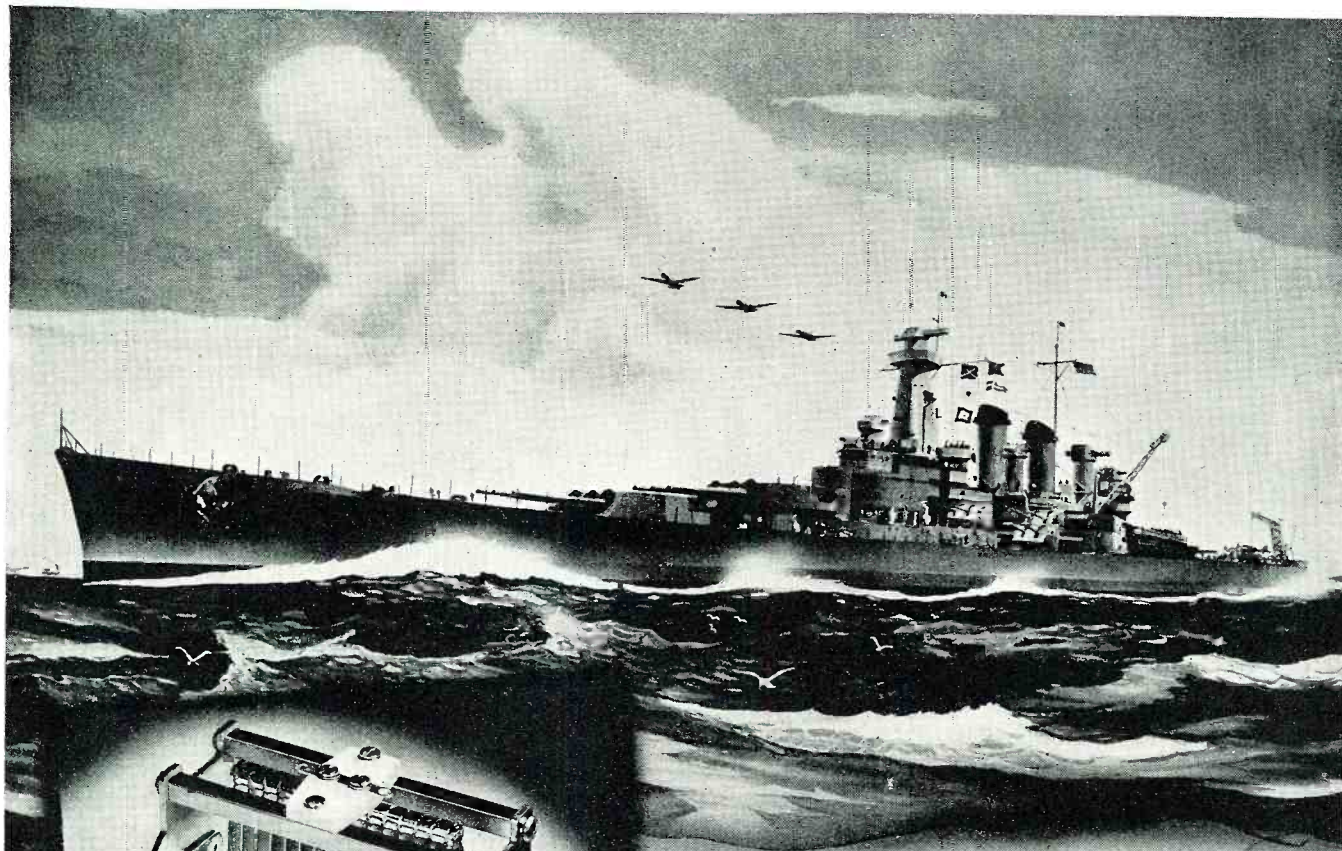

Official U.S. Navy Photo

EYES AND EARS OF THE NAVY

As our Navy prowls the seas, searching out and destroying the enemy, Hammarlund Radio products help guide our great ships to certain victory. In commercial type marine equipment too, you'll find Hammarlund products are outstanding for their record of service.

THE HAMMARLUND MANUFACTURING CO., INC.

460 WEST 34th ST., NEW YORK, N. Y.

Established 1910





Lockheed Electra transport plane.

IN PLANNING for the future, decision has to be made as to what constitutes the "foreseeable future." Insofar as the expectations and suggestions set forth in this article are concerned, the year 1950 has been chosen as the end of the planning period. Obviously, as advancement is made, plans should be revised as necessary.

Improvements Now Planned

A program of improvements in the present system of air traffic control in the United States has been planned by the Civil Aeronautics Administration. This program is being activated as rapidly as funds are made available inasmuch as the facilities and equipment involved have been developed to a substantial degree and are ready for application with little or no delay.

Included is an improved navigation system using very high-frequency radio ranges and instrument landing systems, the provision of more adequate air-ground and point-to-point communication facilities, the establishment of an automatic system for the handling of flight data and improved control procedures based on the use of the new facilities.

Under this program, successive landings at airports during instrument weather conditions are expected to be possible at 3-minute intervals. Thus, the capacity of a properly facilitated

airport will be approximately 20 arrivals and 20 departures or approximately 40 aircraft movements per hour. This compares very favorably with the present situation whereby airports today can handle only approximately 10 aircraft movements per hour during instrument weather conditions under conventional procedures.

Along the airways substantial reduction in time separation should be possible between aircraft flying at the

same altitude. Instead of the 15-minute separation between aircraft which applies on some airways today due to insufficient fixes, and a minimum of 10-minute separation on all other airways, it is expected that the improvements planned will make possible a reduction in this separation to perhaps 5 minutes.

This means that the plans of the Civil Aeronautics Administration which are now ready and which can be placed into effect in the immediate

FUTURE AUTOMATIC AIR TRAFFIC CONTROL DEVICES

By **GLEN A. GILBERT**
Chief, Air Traffic Control Division, CAA

Postwar program of improvements in air traffic control systems planned by the CAA.



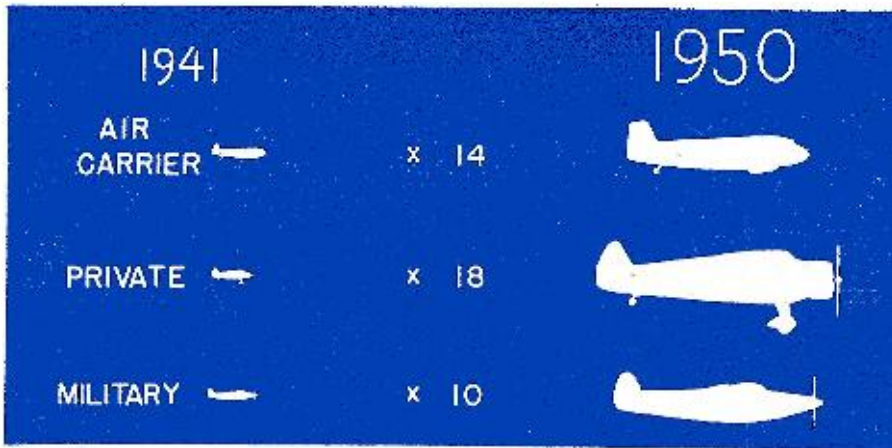

Fig. 1. Estimated increases in air traffic by 1950. For air carrier aircraft 14 times, private aircraft 18 times and for military aircraft 10 times.

future should result in an increase of at least 4 times the present capacity of the United States system of air traffic control.

Air Traffic Development

Will this expansion be sufficient to provide for future needs? Many estimates have been made recently as to the amount of air traffic that will develop after the war. A careful analysis of these estimates and expectations indicates several assumptions which have been generally accepted. These are:

1. Scheduled air passenger traffic by 1950 will increase to approximately ten billion passenger miles, or 5 times the present air passenger traffic.
2. Air cargo by 1950 will amount to at least six hundred million ton miles of freight, express and mail moved by air annually, or 30 times that being transported in commercial air carriers today.
3. A total of approximately five hundred thousand aircraft will be in service by 1950 as compared to approximately thirty thousand before the war.

Based on the foregoing, it appears logical to conclude that increases in

air traffic (Fig. 1) by 1950 over that existing in 1941 will be approximately 14 times for air carrier aircraft, 18 times for private aircraft and 10 times for military aircraft.

If these expectations become a reality, it is obvious that the improvements now planned will merely be stop-gaps. Further advancement in the field of air traffic control will be required in the years immediately following cessation of hostilities. Such advancement should be aimed at attaining the following ultimate improvement:

1. Elimination of voice as a communication medium for air traffic control.
2. Establishment of facilities and development of procedures which will permit the flow of air traffic in the same volume and with the same frequency during instrument weather conditions as is possible during contact weather conditions.
3. Elimination of the human element in the control of air traffic through the use of automatic devices.

At this writing it appears that the objectives stated above cannot be realized fully in the foreseeable future. Therefore, the plans that are set forth

Fig. 2. (Left) Symbolizes cooperation between approaching aircraft via radio during peacetime operation and (right) during war when radio silence is essential.

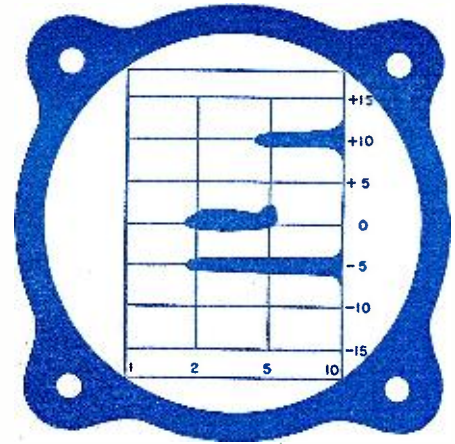
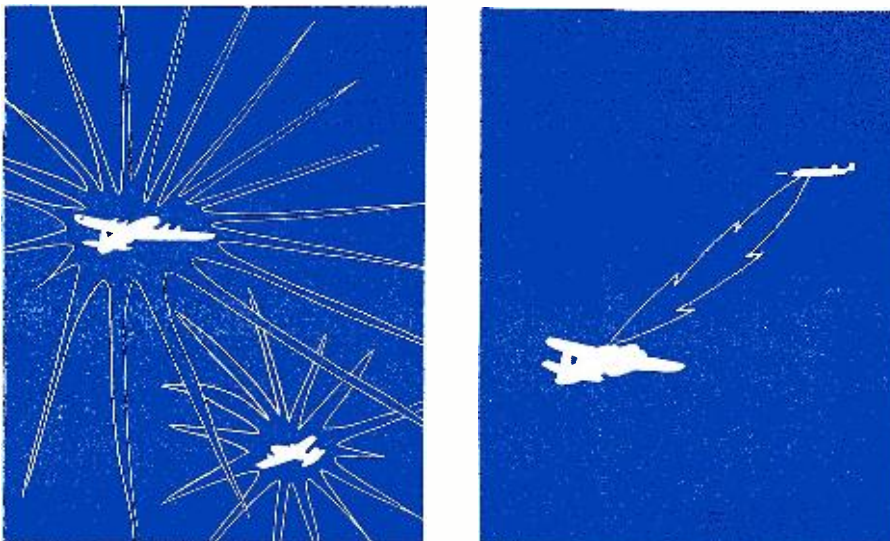

Fig. 3. Vertical separation indicator determines clearance between planes in flight.

in the remainder of this article are limited to those which are considered within the realm of practicability. The existing air traffic control system and the navigation and communication facilities of the Civil Aeronautics Administration will provide the basis which will permit refinement and improvement to meet the future needs of air traffic control along the lines suggested herein.

Influence of War Developments

Much has been said about the possibilities of wartime developments revolutionizing or at least radically changing the present system of air traffic control. The war, without question, has accelerated many technical developments. Special progress has been made in the field of electronics. However, application of the various principles and techniques developed has of necessity been directed entirely toward wartime needs.

It appears, therefore, that very few, if any, wartime technical developments will be immediately applicable for the control of air traffic without change to meet peacetime needs. The end of the war will bring improved technical principles and techniques, but their application to peacetime requirements will have to be worked out.

As an example in support of this line of reasoning it might be pointed out that there is a wide-spread opinion that radar devices will greatly change air traffic control in the immediate postwar period. An analysis of the principle of radar indicates that it has its main advantage in detecting the presence of objects which will not "cooperate," such as enemy airplanes and ships during wartime. To obtain such detection it is necessary to provide complicated apparatus involving high cost, substantial weight and special technique for operation.

In the control of peacetime aircraft, however, the situation is entirely the reverse (Fig. 2) in that all aircraft will cooperate. In other words, devices can be placed on board peacetime aircraft which will reveal their presence. Thus, it becomes possible



Fig. 4. Horizontal separation indicator. Dots indicate position of other planes.

to apply a different technique for the detection of aircraft for air traffic control purposes in peacetime which will involve less complex apparatus, less cost, less weight and simpler operation. Certainly some of the improved electronic techniques developed during wartime will be used for air traffic control, but application will be for peacetime requirements, meeting entirely different specifications than those existing under wartime conditions.

In attempting to eliminate or reduce all limitations of air traffic control so as to increase the capacity and raise the efficiency of the system to meet future needs, several devices for installation in aircraft appear to provide possible solutions. These devices will be identified as "collision warning devices," an "automatic position reporter" and a "traffic clearance indicator." The latter two devices may ultimately be compiled to provide a "block signal system."

Collision Warning Device

The ultimate solution for the control of the large number of aircraft anticipated in the future will require that some means be provided which will permit the shifting of a substantial amount of responsibility for the avoidance of collision from ground agencies to the individual pilots of aircraft. In other words, each pilot flying in instrument weather conditions should be able to avoid collision with other aircraft by directly observing indications of the positions of the other aircraft. The means to accomplish this will probably be in the form of a "collision warning device."

Development of one such device, identified as a "vertical separation indicator," was commenced some time prior to the war by the Civil Aeronautics Administration. This device (Fig. 3) will permit a pilot, by reference to an instrument upon the aircraft instrument panel, to determine at a glance the vertical separation between his aircraft and other aircraft within a fixed radius, and will also indicate roughly the horizontal distance of the other aircraft. The pilot will thus be enabled to maintain a

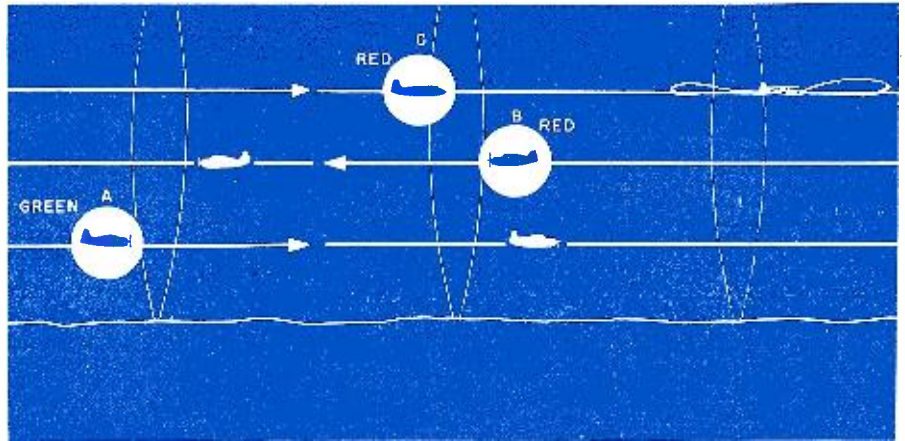

Fig. 6. Block signal system, similar to that of the railroads prevents plane from entering block until cleared, either by plane within changing altitude or leaving area.

specified minimum amount of vertical separation between his aircraft and other aircraft within a certain radius during climb, level flight and descent.

A somewhat different device might be provided as a "horizontal separation indicator." This instrument would be a screen on which various size dots would indicate the relative position of other aircraft (Fig. 4) located within an area ahead of the aircraft concerned and within at least 45° above and below as well as to the right and left. The size of each dot would represent the approximate distance to the indicated aircraft and the location of the dot the angular position of the other aircraft.

These two separator devices together would provide a more complete warning than either device by itself, but the large amount of equipment required would probably destroy the practicability of the combined unit.

Automatic Aircraft Position Reporter

The development of an automatic aircraft position reporter would materially contribute to the reduction of one of the major limitations of the

present air traffic control system—the use of voice as a communication medium. This device would permit an aircraft to actuate a reporting mechanism as it passes each fix along the airways in much the same way as a train trips certain signals as it passes predetermined points on its route. This plan, briefly, would involve (Fig. 5) the use of a *vertical pattern transmitter* at each fix, a *receiver in each aircraft* to indicate the entrance of the plane into this pattern, an *aircraft transmitter* continuously set by a controlling altimeter and put into operation under the control of the fix pattern receiver, and a *receiver at the fix* capable of receiving the automatic report signals and relaying them onward to the Airways Traffic Control Center. At the control center the position reports would be fed directly into automatic posting equipment and would appear in proper form and position before the controlling personnel.

Traffic Clearance Indicator

With the establishment of automatic transmission and posting of aircraft position reports and by providing for
(Continued on page 86)

Fig. 5. Automatic aircraft position reporter. This device permits aircraft to actuate a reporting mechanism as it passes each fix along the airways.

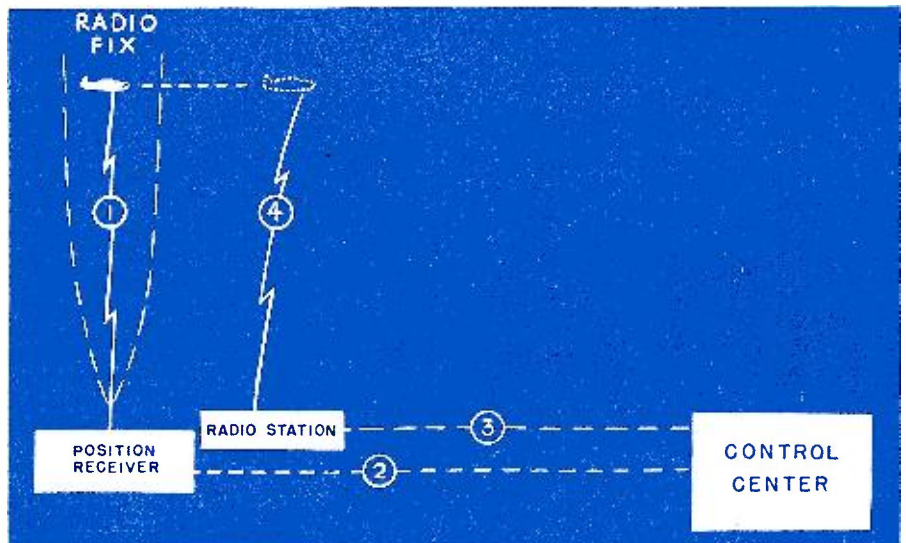



**APPLICATIONS OF
2-WAY RADIO:**

- Police
- Fire
- Public Works
- Fisheries
- Forestry
- Public Utilities
- Railroads
- Taxicab Fleets
- Trucking Fleets
- Buses
- Automobiles

Radio operator's position alongside of driver in the mobile Illinois crime detection laboratory.

POSTWAR TWO-WAY

By **SAMUEL FREEDMAN**

Lt. Comdr., USNR

The problems of cost, design, operation, and frequency allocation of postwar two-way radio systems.

IN planning a two-way radio system, the purchaser, invariably a public agency, always has cause to ponder as to what type of equipment facilities to provide. The question of obsolescence is a matter of concern. In every case known, radio equipment becomes obsolete long before it wears out under normal usage.

The equipment of the past and the present becomes the "white elephant" of the future. Such equipment can be expected to be rather inefficient and uneconomic as compared to modern postwar equipment. But that is not all. What will go further to make it obsolete and necessary to scrap is the likelihood of a radical change in channel assignment such as a shift from the ultra-high frequency band to the microwave band. That definitely will involve new equipment and new antenna systems.

Many radio systems were unable to complete their programs when the

war came and problems of procurement arose. They contemplate to both complete and expand their program postwar. In some cases, they have been able to buy a few more units that industry still had unsold on its shelves before changing over to all-out war production of electronic equipment. In addition, a limited number of FM sets have been authorized by the War Production Board to be supplied through a police-radio pool. As is always the case, the latest purchaser obtained the latest type of equipment. Thus far the cost has not been lower as time went on but the equipment itself was more modern and

much superior in performance. Those who waited until recently have purchased Frequency-Modulated equipment instead of Amplitude-Modulated types.

The postwar 2-way radio set must necessarily be different if for no other reason than the new utilizations to which it is going to be put. This time it will not only be for police, sheriff, fire, public works, fisheries, forestry, public utilities, etc., but it will also include railroads, taxicab fleets, trucking fleets, buses, automobiles and other forms of transportation.

Immediately the question will arise: "How about channel space and the



Radio operator's position at the control panels of the Buffalo Police Department radio station.

RADIO SYSTEMS . . .

FCC." Many will claim that the FCC will not grant licenses for such widespread utilization. That would be as wrong as to say that they are opposed to radio development and progress. A study of frequency allocation in the past conclusively indicates that the Federal Communications Commission has done very well in spreading the advantages of radio communication to as many as possible. It tried to make it available for as many utilizations as could be accommodated on frequencies heretofore considered available and feasible.

The Federal Communications Commission, as set up by legislation and as it actually functions, is here to regulate and facilitate the use of radio for the benefit of the people. It gives preference to agencies or groups who need to use it for the protection of life and property in the case of 2-way radio on the ultra-high frequency band. It has not been able to go as far

as it would have had to go in order to accommodate all applicants. For example, it has not been thus far possible to provide channels for railroads and other forms of commercial or private transportation on land.

In the final analysis, the Federal Communications Commission must control licensing to the extent that a license has to depend on which frequency is desired and how many want to use such a frequency. If the applicant can show that he is asking for a frequency that is an empty part of the radio-frequency spectrum, particularly in a region hitherto considered useless for communication, the situation becomes different. For example, an applicant to use a small spot in the microwave band and in a position to prove that he can make equipment work satisfactorily down there has an excellent chance to obtain authorization. This authorization can then be not only for a new channel being

utilized for the first time, but it also can be for utilizations never undertaken before.

This means that in order to use 2-way radio for railroads and commercial users, it is necessary that equipment function on channels other than those heretofore allocated for any other utilization. Specifically this means channels exceeding 300 megacycles and preferably those in excess of 1000 megacycles. Such equipment will definitely be available post-war and would be available tomorrow if the war ended. For example, the writer is in a position to state that an application for patent at this moment is pending which proposes to use microwave communication 2-way for railroads and all forms of transportation on frequencies well into the microwave band. This invention utilizes simple, compact and inexpensive unattended automatic relay stations

(Continued on page 54)



Fig. 1. The electro-magnetic spectrum covering a frequency range from 10 to 10^{20} cycles. The unit XU is equal to 10^{-11} cm.

ELECTRO-OPTICS

By ALBERT A. SHURKUS

Covering the fundamentals of optical and electronic design engineering, including the basic theory of many of our visual test instruments.

Fig. 2. Visibility curve of a normal human eye showing the point of greatest sensitivity.

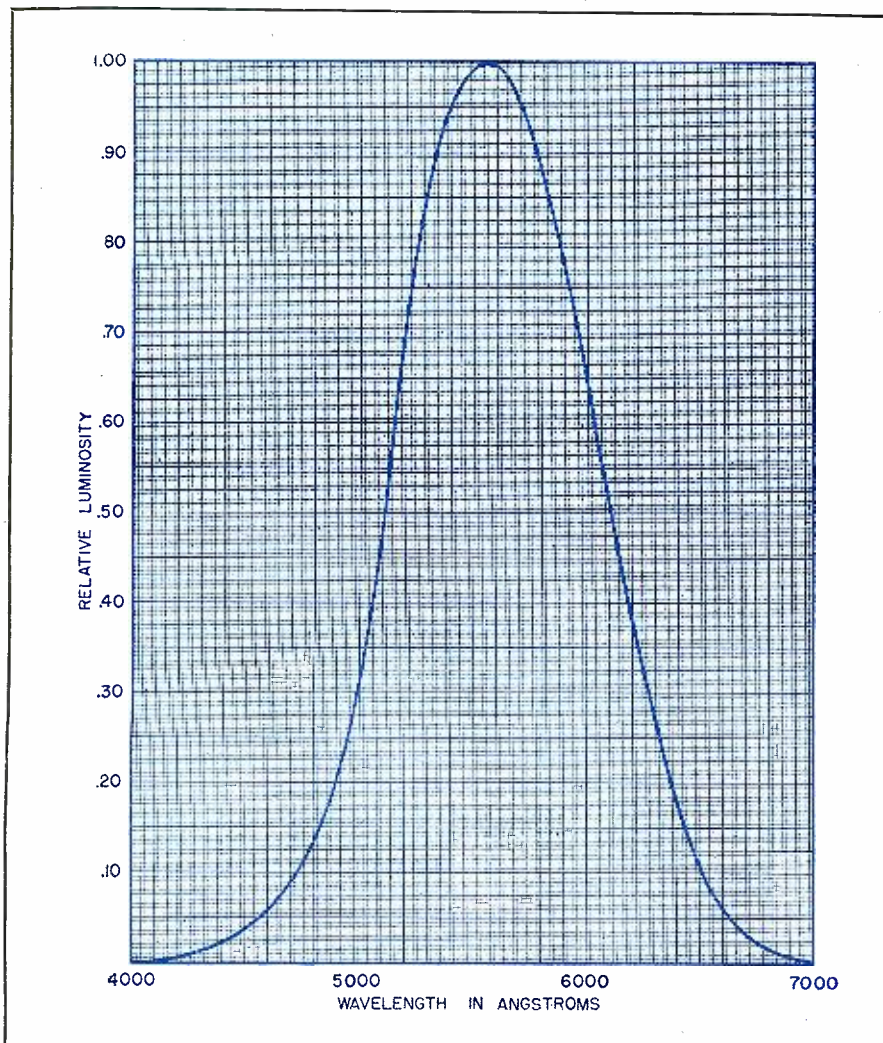

DURING the past twenty years a new science has been in the process of development, although only during the past five has it made any significant progress. This new science, called "Opti-onics"¹ by some, has been referred to in the past as optical electronics or "electro-optics". It is the combination of the two older, and now well-established, sciences of optics and electronics. The combination, although dealing with problems which are, in the main, optical, places greater stress upon electronics.

One need not look far to find these "electro-optical" instruments rapidly replacing visual instruments like spectrophotometers, colorimeters, photometers, fluorimeters, and many others formerly considered the concern of the optical engineer. The rapid acceptance of these new instruments is attributable not only to the ease with which they lend themselves to measurements involving color and light, but also to their speed and lack of fatigue. It is certain, too, that these instruments will meet with even wider acceptance in the future and will enter many new phases of our daily life. For example, photoelectric spectrophotometers will specify the colors of the clothes we wear and the paints we use, photoelectric fluorimeters will measure the potency of some of the vitamins we consume, and photoelectric colorimeters will guard those of us who must work in potentially toxic atmospheres.

Optics is that portion of physics which treats light, its genesis and propagation together with the effects it suffers and produces. This is indeed

¹ Copyrighted trademark of the Bell & Howell Company, Chicago.

a broad field and, hence, it is usual to divide it into the sub-classifications of geometrical, physical, and physiological optics. Geometrical optics is concerned with the design of lenses and lens systems; physical optics treats the production of light and the effects it suffers and produces passing through physical media; physiological optics deals with the effects of light upon the visual mechanism. Of course, it is far beyond the scope of this article to treat any of these branches with any pretext of completeness. All that can be hoped for is that the reader might be given some insight of the science in the most general terms.

Light

Physicists are now satisfied that the excitation of elementary particles of energy like molecules, atoms, and electrons will cause the emission of radiant energy. This excitation may come about in a number of ways, among which are the collision of atoms with rapidly-moving charged particles and the heating of a metal which presents high resistance to the passage of an electric current. This radiant energy may exhibit itself in various forms, the gamut of which we have come to call the electromagnetic spectrum. A pictorial representation of this electromagnetic spectrum is shown in Fig. 1. As can be seen, this radiant energy may be evidenced among other things, as radio waves, infrared rays, light, ultraviolet rays, and X-rays.

Insofar as both are wave motions emanating from excited particles of energy, light is similar to radio waves. Light, however, is most strictly defined as that radiant energy capable of evoking a visual stimulus, although the physicist has now generally fallen into the habit of including both the near ultraviolet (i. e., near to the visible region of the electromagnetic spectrum) and the near infrared. But while radio waves are produced by electric charges that oscillate in a resonant circuit, light waves are produced by electrons oscillating in

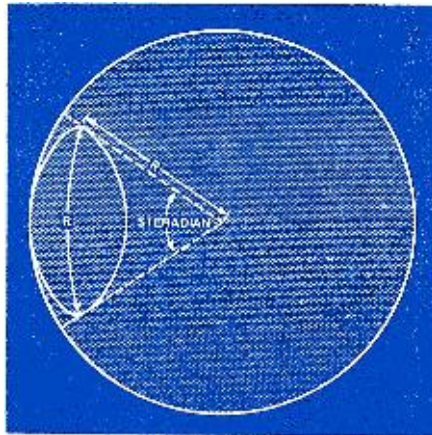

Fig. 4. Method of determining the lumen unit.

the atom itself. Because of the rapidity of the oscillations producing light, its wavelength is extremely short. The wavelength of light is measured in angstrom units, the angstrom being 10^{-8} centimeters,² and is usually symbolized by \AA . The visible spectrum extends from 4000 to 7000 \AA . for the average observer; some eyes, however, can see from 3800 to 7600 \AA .

The retina, it must be pointed out, is not equally responsive to all wavelengths. The ability of the eye to respond to radiant energy varies throughout the visible spectrum and the visibility curve of a normal human eye is shown in Fig. 2. As the curve indicates, the normal eye is most sensitive to radiant energy of 5550 \AA . This visibility function must always be remembered whenever a photoelectric system is used to replace the eye for measurements of color or light intensity.

The Spectrum

The light emitted by a material subjected to some form of excitement can be dispersed, i. e., separated into its various component wavelengths, by a prism or a grating. It was indeed a milestone in optical history when, in the 17th century, Sir Isaac Newton

² 1-inch = 2.54 centimeters. $\therefore 1 \text{ \AA} = 0.0000000047$ "

discovered that a prism could disperse white light. The diffraction grating is a system of very closely spaced equidistant and parallel lines ruled upon a polished surface.

When dispersed, light may be found to have a spectrum consisting of lines, bands, or to be continuous, depending upon the source of radiation (Fig. 3). A line spectrum, as the name implies, consists of isolated lines of various frequencies, and is produced by an element in its gaseous state. It is that spectrum obtained, for example, when an arc is struck between iron or copper electrodes. The arc creates a temperature high enough to vaporize the tips of the metallic electrodes, the vapor being, in turn, excited sufficiently to emit light of characteristic frequencies. The line spectrum is that usually employed for quantitative and qualitative spectrographic analysis since each element possesses its own unique set of characteristic lines. A band spectrum is characteristic of molecules and is produced by a com-

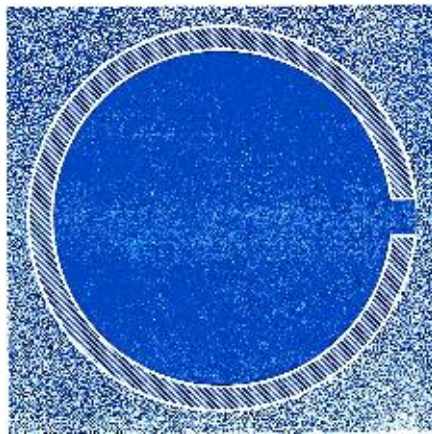
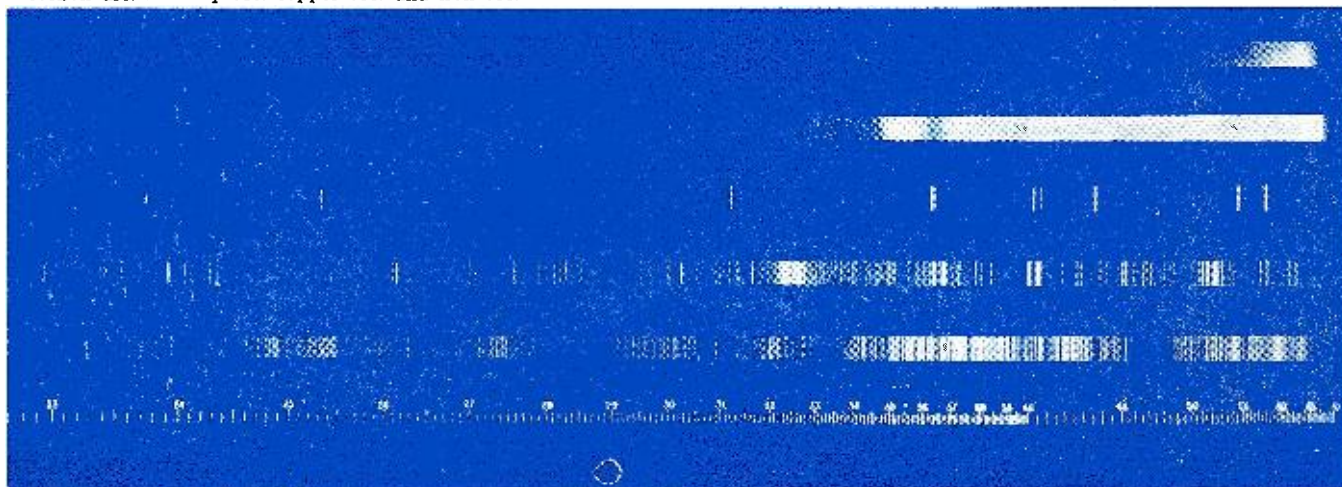

Fig. 5. Cavity to obtain truly black condition.

continuous spectrum is characteristic of solids that have been heated to incandescence, like a tungsten lamp filament. This type of spectrum has, apparently, no structure and can be considered as possessing radiation of all frequencies.

Fig. 3. Spectrographic analysis of various metals. The spectra shown from top to bottom are from an incandescent tungsten lamp, carbon arc, mercury arc, copper arc, and iron arc. Note in the carbon arc the band structure due to the nitrogen in the atmosphere.



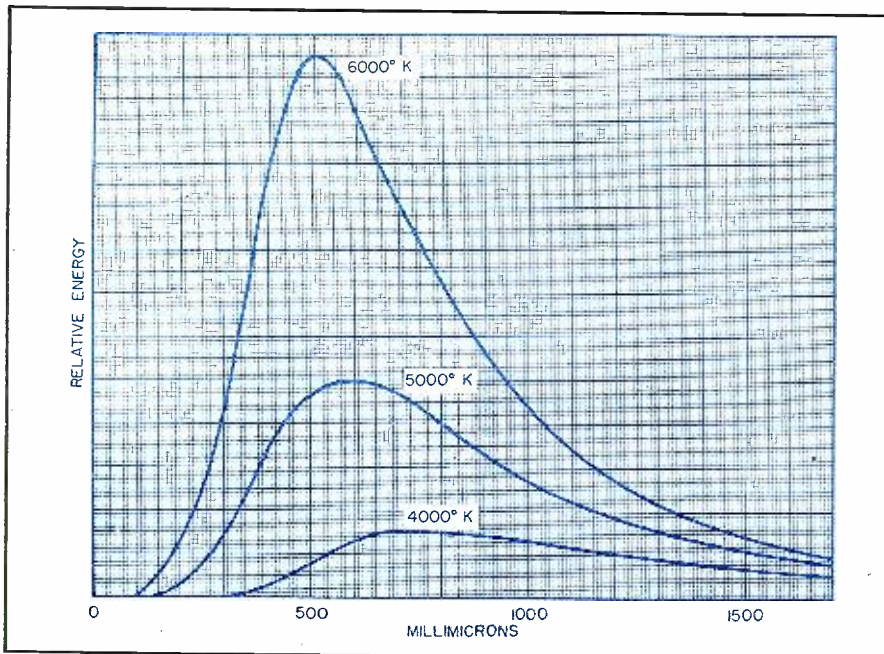

Fig. 6. Relative energy distribution for black bodies at various Kelvin temperatures.

Monochromatic is the term that is applied to radiation of a single frequency or a very narrow band of frequencies, and monochromatic light is obtained by the isolation of a single-radiation frequency or narrow band of frequencies from any of the spectrum types listed above. It is, of course, most easily obtained by the isolation of a single line from a line spectrum. If the line spectrum is of a simple structure, like that of mercury, the isolation can be achieved through use of filters. If, on the other hand, the spectrum is complex, like that of iron, or continuous, then an optical instrument employing the dispersion produced by either a prism or a diffraction grating must be used. Such an instrument is the wavelength spectrometer.

A band of frequencies (or wavelengths) can be isolated through use of colored filters placed before an incandescent source. The narrowness of the isolated band is dependent upon the filters chosen for the task. In general, dyed gelatine filters are able to pass more energy in a narrow band than can colored glass filters. Glass filters, however, are preferable for this work because they are less apt to

change their characteristics with age and are less liable to be adversely affected by heat.

Photometric Units³

The original standard of light intensity used was the English Standard Candle defined as a spermaceti candle $\frac{1}{8}$ " in diameter made to burn at a rate of 120 grains per hour with a flame height of 45 millimeters. Spermaceti is a waxy solid separated from the oil of the sperm whale. It became apparent with use, however, that a standard such as this was difficult to maintain constantly and to duplicate. Following the appearance of the carbon filament, therefore, the national standardizing laboratories of France, Great Britain, and the United States concurred upon an international agreement in 1909 basing the definition of the international candle upon a group of well aged and carefully operated carbon-filament lamps. In this country, the candle is a specified fraction of the average intensity of a group of 45 carbon-filament lamps

³ Parts of this section and that following are based upon "Illuminating Engineering Nomenclature and Photometric Standards" approved by the American Standards Association, February 27, 1942.

Fig. 7. Portion of Fig. 1, showing an expanded view of the visible spectrum region.

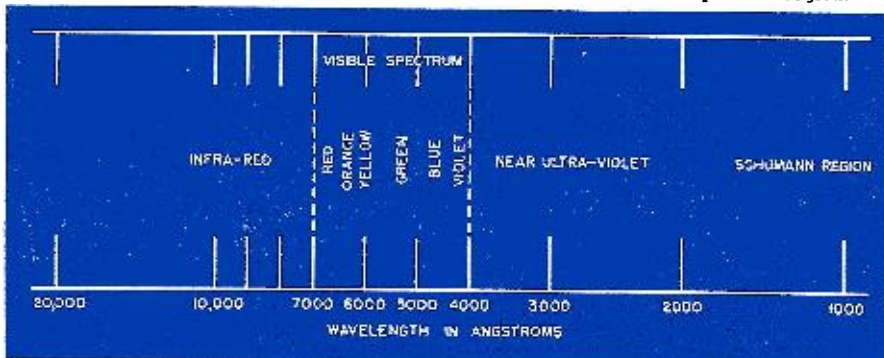

preserved at the National Bureau of Standards. Since the candle is now the easiest photometric unit to maintain, all other photometric quantities are defined with respect to it.

Just as the current through an electron tube can be referred to as a flow or flux of electrons, so can light be regarded as a flow or flux of radiant energy capable of evoking visual stimuli. The time rate of flow of light is called luminous flux, the unit of which is the lumen. The lumen is equal to the luminous energy flowing through a unit solid angle (steradian) from a point source of light with a luminous intensity of one candle. The steradian is defined as that angle included in the cone formed by a circle on the surface of a sphere, the diameter of this circle being equal to the radius of the sphere. (See Fig. 4.) It must be remembered that the point source is but a mathematical concept used to provide the solid angle with a point for its apex. In practical optics, a source can be considered to be a point if the distance from it is at least 20 times as great as its maximum dimension. Since there are 4π steradians in a sphere, a point source emitting light uniformly in all directions radiates 4π lumens per candle. If that sphere were one foot in radius, then the illumination falling upon one square foot of the surface of that sphere would be one footcandle.

The concept of luminous intensity is applicable only when the source is small enough to be treated as a point. In many instances the source is too large for that and the corresponding unit is brightness. As commonly used, brightness usually refers to the intensity of the sensation that results from viewing extended surfaces or spaces. In the photometric sense, brightness is the luminous intensity of any surface in a given direction per unit of projected area of the surface as viewed from that direction. The amount of illumination falling upon a surface is the density of the luminous flux on that surface; it is numerically equal to the luminous flux (in lumens) divided by the area of the surface when the latter is uniformly illuminated.

There are many more photometric units than the four defined, but the purpose of this article is to discuss the general concepts of optics. As the need arises, however, we shall discuss in later sections those units of less basic importance.

Light Sources

Whenever an optical device is used, it is in association with some source of light. In some instances, that light source may be readily apparent, like the lamp in a projector; in others, the light source may be seemingly divorced from it, like the sun in photography. The production and distribution of large amounts of light is now a recognized branch of electrical engineering. The aim of these particular specialists, however, is efficiency and

(Continued on page 74)

Nomographic Evaluation of Complex Numbers

VARIOUS components of a complex number can be evaluated by passing a straightedge through two points such as those determined by R and X. The intersection of the straightedge with the θ and the Z lines determines the angle and magnitude of impedance with one setting.

EXAMPLE:

Resistance—5 ohms
 Reactance—6 ohms
 Angle from Chart—45°
 Impedance from Chart—8.46 ohms.

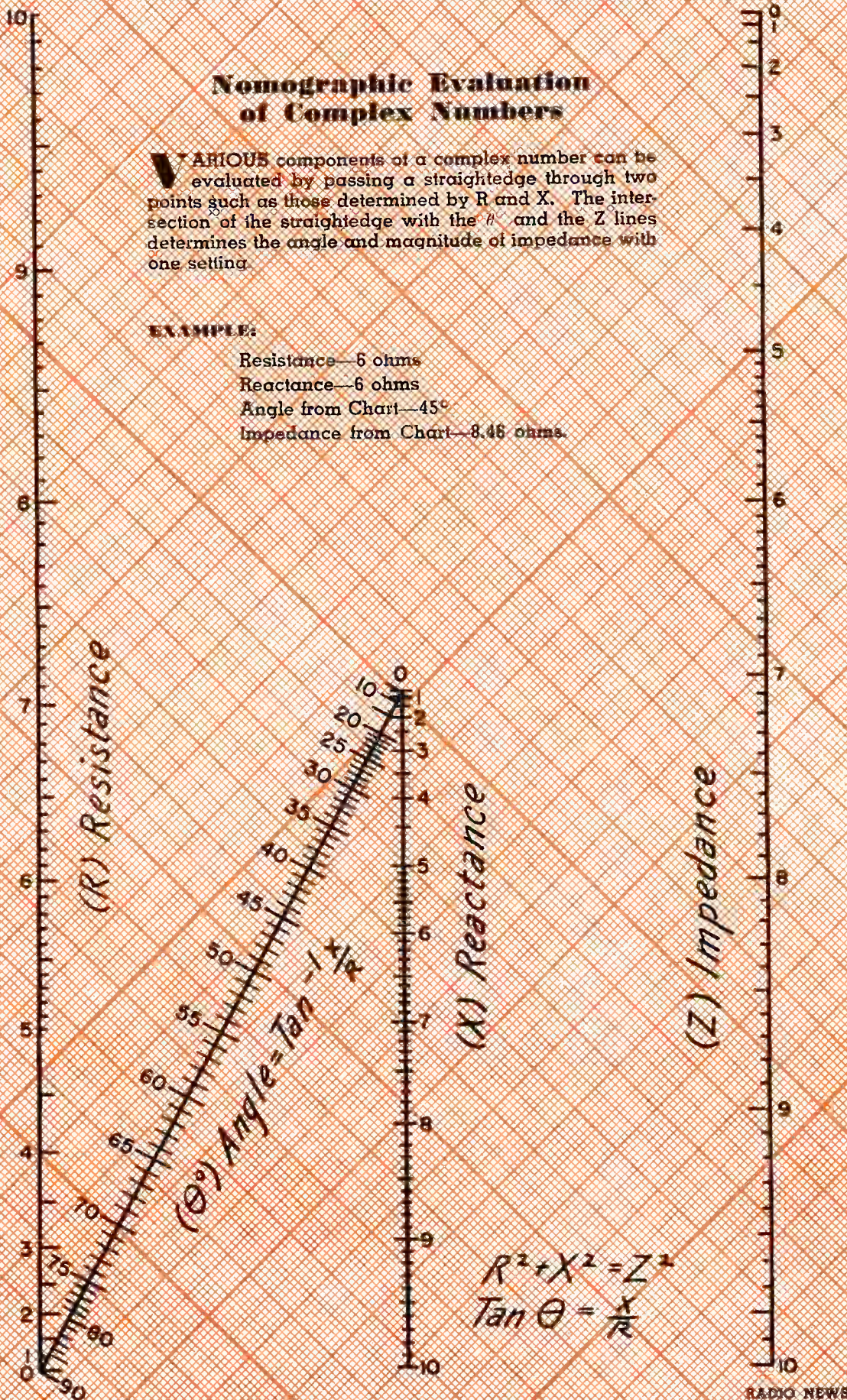

Simple Square-Wave Generator

Constructional details of a simple square-wave generator used to evaluate the amplitude and phase response of an amplifier.

By RUFUS P. TURNER

Consulting Eng., RADIO NEWS

THE subject of fidelity continually offers a puzzle to amplifier servicemen and audio experimenters. It is soon recognized that any but the critically trained ear is a poor criterion and that some sort of instrumentation is therefore necessary. Discriminating builders of audio equipment, amplifiers and otherwise, make frequency runs on their products. But these tests serve only to reveal the frequency-vs.-amplitude response; and occasionally when they yield a flat characteristic, final performance may not be pleasing to the ear. For one thing, the common audio-frequency response tests do not take into consideration phase distortion. And these tests include measurements made with a distortion meter or wave analyzer, as well as those performed with sine-wave oscillator and flat-response output meter.

A signal may be subjected to various phase displacements as it passes through an amplifier or other audio-frequency network. In passing from grid to plate in a single stage, a phase

shift of 180 degrees theoretically takes place. Actually, however, this shift may not be exactly 180°, due to the action of circuit parameters, nor is it the same for all frequencies. Since the signal is composed of a fundamental and several harmonic frequencies, and each of these components undergoes a different amount of phase shift, the waveform of the output signal may be expected to deviate from that of the original input signal. This distortion is not evaluated by the common methods of audio-response testing, but is entirely capable of spoiling fidelity.

Testing audio systems by means of square waves does take into consideration phase shift, as well as amplitude response. The method is rapid, since one indication reveals the overall response of the system, rather than specifying only a part of the response, and enables both qualitative and quantitative appraisals to be made. The response of an amplifier or network to square waves of appropriate period has been shown to

specify completely its response, in phase and magnitude, to a sinusoidal signal of any frequency.

This method of testing consists of applying a square-wave signal to the input terminals of the amplifier or network and observing its pattern oscillographically both before and after the network. The squareness of the waveform will be preserved as the signal passes through the amplifier if the amount of distortion introduced by the unit is negligible. The output-wave shape will deviate from squareness according to the amount and character of the distortion. A rapid means is thus provided for continuous indication while circuit changes are made to improve fidelity.

Response of an amplifier to the square-wave test is explained in the following manner: If a given voltage is abruptly applied to the input terminals and then held constant, the output which results is the *transient characteristic* of the amplifier and this characteristic indicates, as may be shown by operational calculus, response of the amplifier to any type of input voltage. A *unit function* is a unit voltage applied suddenly to the amplifier and then held at a constant level. Amplifier response to a unit function has been shown to specify completely its response to a sine-wave signal of any frequency, in phase and in amplitude.

A square wave of good shape rises sharply to a maximum value, remains at that level for a fixed time interval, drops sharply to a minimum value, maintains that level over an interval corresponding to the maximum period. The cycle is repeated at a predetermined frequency. Such a waveform is shown in Fig. 2. Observe that the wave front of the ideal square (or rectangular) wave is exceedingly steep.

The steep wave front of the square wave corresponds to a train of unit-function voltages, and thus becomes invaluable for testing the transient characteristic of an amplifier or network. The steeper the rise and fall of the waveform and the more uniformly horizontal its flat top, the more closely does the square wave approximate the unit function. One commercially-built square-wave generator provides a complete rise in one-thousandth of a cycle. That is, 16.6 micro-seconds at 60 cy.

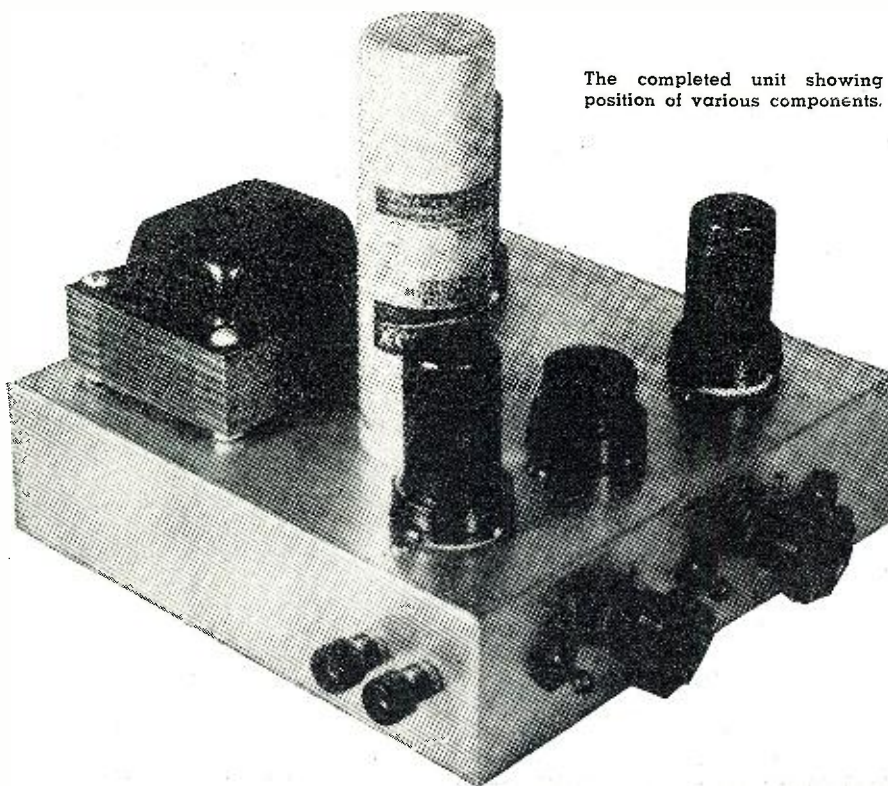

The completed unit showing position of various components.

BROADCAST STATIONS AS FREQUENCY STANDARDS

The application of standard broadcast stations for frequency calibrations. This method is simple and sufficiently accurate.

By GUY DEXTER

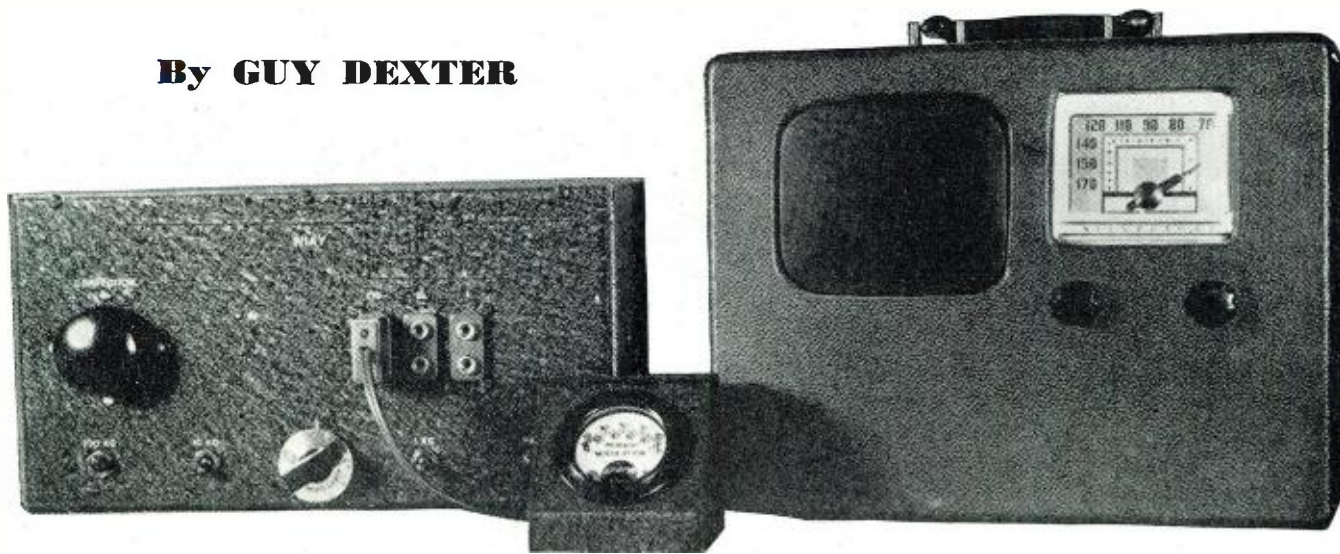

Test set-up using either a self-excited or crystal oscillator, a meter to observe zero beat, and a radio receiver.

REGULATIONS require that standard broadcast stations maintain their carrier frequencies within plus or minus 20 cycles, irrespective of the frequency magnitude. During operation, broadcast carriers are usually well within these prescribed tolerance limits, never varying from assigned values by more than a few cycles. These facts would indicate that broadcast carriers afford a readily available means for checking calibration of oscillators, frequency standards and similar instruments when a short-wave receiver is not available for WWV reception or when reception conditions impair WWV pickup. The accuracy obtainable by use of these carriers will be suitable for most practical electronic purposes.

The instrument generally employed by the experimenter for frequency calibration is a self-excited or crystal oscillator operating at 100 kc. This device is standardized by bringing one of its harmonics to zero beat (by means of a *calibration control* arranged for tuning the oscillator frequency over a narrow band) with some signal of known accuracy. The oscillator may then furnish a multiplicity of accurate spot frequencies by means of which other oscillators, receivers, monitors, signal generators, and similar electronic instruments may be calibrated.

If the standard frequency oscillator

is provided with a 10-kc. multivibrator, harmonics of the latter will be available at considerable strength throughout the broadcast band, and any station carrier may be utilized for standardization, since broadcast carriers are spaced 10 kilocycles apart. Most experimental standards, particularly those which are constructed for urgent use, do not embrace a multivibrator stage, however, and only broadcast carriers which are multiples, of 100 kc. may be employed.

For the experimenter's convenience, two tables have been prepared for readily locating broadcast stations which operate on frequencies which are multiples of 100 kc. One hundred and eight broadcast stations operate throughout the country on the following 100-kc. multiples: 600, 900, 1000, 1100, 1200, 1300, 1400, 1500 and 1600 kc. No other even multiples are assigned. Eighty-three of the 108 stations employ carrier frequencies of 1400 kc. Chart I lists these stations alphabetically by call letters. Locations of the station *transmitters* are given in this chart. Chart II lists the same stations by frequencies.

Method of Utilizing

For setting a standard-frequency oscillator, the experimenter should select the strongest carrier available at his receiving location. He should also select the highest-frequency carrier

when several of equal strength are available, and must pick the carrier which is free of heterodyne and other interference. The chart will aid this selection. Any broadcast receiver will be satisfactory.

The standard-frequency oscillator is fed into the antenna and ground terminals of the receiver by the loosest possible method of coupling which will pass a signal of sufficient strength into the receiver. As the output circuit of the standard-frequency oscillator is of the low-impedance type which tends to "short" the broadcast signal, coupling should be reduced still further.

When setting to zero beat, it is likely that the process will have to be carried out while a program is in progress. It is desirable, therefore, to reduce the volume to a low level and it will be necessary to recognize zero beat through the music or speech being received. This entails a particularly careful bit of listening. As the beat frequency decreases to a very low value, its low pitch will apparently disappear completely, and this point of disappearance may erroneously be interpreted as zero beat. However, it may be observed by careful listening that a very low beat frequency is still superimposed upon the speech or music, giving the latter a hoarse character. At exact zero beat, all hoarseness and all waxing and waning will
(Continued on page 78)

CHART I

Broadcast Stations by Call Letters

Call	Transmitter Location	Frequency kilocycles	Call	Transmitter Location	Frequency kilocycles
KELD	North of El Dorado, Arkansas.....	1400	WCOS	Columbia, So. Carolina.....	1400
KENO	Las Vegas, Nevada.....	1400	WDAS	Philadelphia, Pennsylvania.....	1400
KFPW	Ft. Smith, Arkansas.....	1400	WDEF	Chattanooga, Tennessee.....	1400
KFRU	Columbia, Missouri.....	1400	WDWS	Champaign, Illinois.....	1400
KFSD	San Diego, California.....	600	WELL	Battle Creek, Michigan.....	1400
KFVS	Cape Girardeau, Missouri.....	1400	WEOA	Evansville, Indiana.....	1400
KGFL	Roswell, New Mexico.....	1400	WEST	Easton, Pennsylvania.....	1400
KGKL	San Angelo, Texas.....	1400	WFBR	Baltimore, Maryland.....	1300
KGLO	Mason City, Iowa.....	1300	WFOR	Hattiesburg, Mississippi.....	1400
KIUN	Pecos, Texas.....	1400	WGBR	West of Goldsboro, No. Carolina.....	1400
KIUP	Durango, Colorado.....	1400	WGIL	Galesburg, Illinois.....	1400
KJBS	San Francisco, California.....	1100	WGRC	New Albany, Indiana.....	1400
KJR	Seattle, Washington.....	1000	WHBQ	Memphis, Tennessee.....	1400
KLCN	Near Blytheville, Arkansas.....	900	WHDF	Calumet, Michigan.....	1400
KLUF	Near Galveston, Texas.....	1400	WHLB	Virginia, Minnesota.....	1400
KONO	San Antonio, Texas.....	1400	WHUB	Cookeville, Tennessee.....	1400
KORN	Fremont, Nebraska.....	1400	WHYN	Hadley Falls, Massachusetts.....	1400
KOBH	Rapid City, So. Dakota.....	1400	WICC	Bridgeport, Connecticut.....	600
KOKO	La Junta, Colorado.....	1400	WINC	Winchester, Virginia.....	1400
KOL	Seattle, Washington.....	1300	WINS	Kingsland, New Jersey.....	1000
KRE	Berkeley, California.....	1400	WJAC	Johnstown, Pennsylvania.....	1400
KRKO	Everett, Washington.....	1400	WJDX	Jackson, Mississippi.....	1300
KRLC	Lewiston, Idaho.....	1400	WJHO	Opelika, Alabama.....	1400
KROD	El Paso, Texas.....	600	WJLB	Detroit, Michigan.....	1400
KSJB	Jamestown, No. Dakota.....	600	WJLD	Bessemer, Alabama.....	1400
KSTP	St. Paul, Minnesota.....	1500	WJSV	East of Wheaton, Maryland.....	1500
KTEM	Temple, Texas.....	1400	WJZM	Clarksville, Tennessee.....	1400
KTNM	Tucumcari, New Mexico.....	1400	WKMO	Kokomo, Indiana.....	1400
KTOK	Oklahoma City, Okla.....	1400	WKPT	Kingsport, Tennessee.....	1400
KTSW	Emporia, Kansas.....	1400	WKWK	Wheeling, West Virginia.....	1400
KTTS	Springfield, Missouri.....	1400	WMAN	Mansfield, Ohio.....	1400
KTUC	Tucson, Arizona.....	1400	WMBR	Jacksonville, Florida.....	1400
KVFD	Near Fort Dodge, Iowa.....	1400	WMFD	Wilmington, No. Carolina.....	1400
KVGB	Great Bend, Kansas.....	1400	WMGA	Northeast of Moultrie, Georgia.....	1400
KVOR	Colorado Springs, Colorado.....	1300	WMIN	St. Paul, Minnesota.....	1400
KVRS	Rock Springs, Wyoming.....	1400	WMSL	Decatur, Alabama.....	1400
KWLK	Longview, Washington.....	1400	WAOI	Selma, Texas.....	1200
KWON	Bartlesville, Oklahoma.....	1400	WOOD	South of Grand Rapids, Michigan.....	1300
KWYO	Sheridan, Wyoming.....	1400	WORD	Northeast of Spartanburg, So. Carolina.....	1400
WABY	Colonia, New York.....	1400	WPAY	Portsmouth, Ohio.....	1400
WAGF	North of Dothan, Alabama.....	1400	WRAC	Williamsport, Pennsylvania.....	1400
WARM	Dunmore, Pennsylvania.....	1400	WRDO	Augusta, Maine.....	1400
WASH	Grand Rapids, Michigan.....	1300	WREC	Near Rugby Park, Tennessee.....	600
WATL	Atlanta, Georgia.....	1400	WRJN	Mount Pleasant, Wisconsin.....	1400
WATW	Ashland, Wisconsin.....	1400	WRRN	Warren, Ohio.....	1400
WBLK	Clarksburg, West Virginia.....	1400	WSAM	Saginaw, Michigan.....	1400
WBNY	Buffalo, New York.....	1400	WSAU	Wausau, Wisconsin.....	1400
WBTH	Williamson, West Virginia.....	1400	WSBA	North of York, Pennsylvania.....	900
WBTM	Danville, Virginia.....	1400	WSJS	Near Oldtown, No. Carolina.....	600
WCAO	Near Baltimore, Maryland.....	600	WSLB	Ogdensburg, New York.....	1400
WCBI	Columbus, Mississippi.....	1400	WSRR	Stamford, Connecticut.....	1400
WCBM	Baltimore, Maryland.....	1400	WTAM	Brecksville Village, Ohio.....	1100
WCFL	York Township, Illinois.....	1000	WTCM	Elmwood Township, Michigan.....	1400
WCNC	Elizabeth City, No. Carolina.....	1400	WWRL	Woodside, L. I., New York.....	1600

CHART II

Broadcast Stations by Frequencies

600 kc.
KFSD, KROD, KSJB, WCAO, WICC, WREC, WSJS

900 kc.
KLCN, WSBA

1000 kc.
KJR, WCFL, WINS

1100 kc.
KJBS, WTAM

1200 kc.
WAOI

1300 kc.
KGLO, KOL, KVOR, WASH, WFBR, WJDX, WOOD

1400 kc.
KELD, KENO, KFPW, KFRU, KFVS, KGFL, KGKL, KIUN, KIUP, KLUF, KOND, KORN, KOBH, KOKO, KRE, KRKO, KRLC, KTEM, KTNM, KTOK, KTSW, KTTS, KTUC, KFVD, KVGB, KVRS, KWLK, KWDN, KWYO, WABY, WAGF, WARM, WATL, WATW, WBLK, WBNY, WBTH, WBTM, WCBI, WCBM, WCNC, WCOS, WDAS, WDEF, WDWS, WELL, WEOA, WEST, WFOR, WGBR, WGIL, WGRC, WHBQ, WHDF, WHLB, WHUB, WHYN, WINC, WJAC, WJHO, WJLB, WJLD, WJZM, WKMO, WKPT, WKWK, WMAN, WMBR, WMFD, WMGA, WMIN, WMSL, WORD, WPAY, WRAC, WRDO, WRJN, WRRN, WSAM, WSAU, WSLB, WSRR, WTCM

1500 kc.
KSTP, WJSV

1600 kc.
WWRL

MINE LOCATORS

The problems encountered by Britain's Ministry of Supply in producing an effective electrical mine detector.

By CONNERY CHAPPELL

British Journalist and Author

COMPARED with the complexities of aircraft or naval design, the mine detector is an extremely simple, almost elementary job—consisting as it does of a mere 250 components, involving 29 sub-assemblies.

In battle it has proved enormously valuable; it speeds up the operation of clearing a land minefield, and helps the attacking force to maintain its momentum.

The principle of the electric mine detector is simple: it is based on the familiar idea of the balanced mag-

netic fields. Two coils are placed close together; a current passes through one and sets up a second electric field through induction. The two fields are equally balanced and give no reaction—but create an oscillating signal if the balance is upset by a metallic object. The soldier operating the detector hears a different note on his earphones and knows that he is near metal.

When the demand for a mine detector first became urgent, the task of producing one was turned over to the research branch of *Britain's Min-*

istry of Supply, which soon had nine different experiments in hand. The basic principle was apparent from the start; the problem was to devise an instrument that would stand up to the roughest conditions of active service, would not weigh more than a reasonable additional load for a soldier in battle equipment, be fool-proof in operation, require only a minimum operating team, and be composed of simple interchangeable parts allowing for quick replacement.

At the beginning of October, 1941, the research sections of the Ministry of Supply were nearing the final stages of their experimental work, and trials had been fixed for October 25. But on October 13 they received particulars of a new model produced independently by two lieutenants in the Polish forces.

It was obvious at once that the Polish design was very good. It embodied no startling principles; there was nothing new in its approach. But its actual layout suggested advantages from the point of view of manufacture and operation. So it was decided to base the trials on this design, and the Ministry was left with a week in which to produce a trial model.

A London radio firm was chosen; Ministry research engineers moved into the factory; special laboratory facilities were provided; the firm's own research men co-operated. By working more than twelve hours a day they produced the first electric mine detector in time for its trial.

The tests were satisfactory, and the usual prolonged field tests were started. But the need was urgent, and the Ministry decided to take a chance. Assuming that the results would be satisfactory, an order was placed for the finished article. Production started at the beginning of December, 1941; special steps were taken to speed things up so that there would be a supply of detectors in the Middle East before bulk supplies came through.

Externally, the detector consists of a fiat plate, known as the search probe, with rounded ends, about 15 inches long, 8 inches wide and three-quarters of an inch deep. A movable shaft is fixed into the center of the upper plate, and there are two control knobs on the handle of the shaft. The remainder of the equipment is contained in a haversack on the operator's back.

Inside the haversack are the oscillating and amplifying circuits, the sensitivity control and the high and low tension batteries. A cable runs up the shaft from the search probe; the headphones, when not in use, are stowed in a separate compartment in the haversack.

There are two electric coils inside the probe. They occupy each of the rounded ends of the probe and slightly overlap. They are held rigidly in position by wax. If they are moved out of position at all the balance of the

(Continued on page 73)

American-made mine detectors being used to clear out mine field near St. Stefano, Sicily.



PANORAMIC RECEPTION

By **C. T. READ**

Eng. Dept., The Hallicrafters Co.



The S-35 panoramic adapter and SX-28 communications receiver mounted as a unit.

★

An adapter unit used in conjunction with a communications receiver for visual observation and analysis of the radio-frequency spectrum

★

THE panoramic radio receiver is one of the newest and most interesting applications of the cathode-ray tube. As announced by the Hallicrafters Co. a few months before Pearl Harbor, it took the form of an auxiliary unit designed to work in conjunction with a standard receiver, usually their Model SX-28. The necessary power supplies, intermediate frequency and video-frequency amplifiers, sawtooth oscillator, reactance modulator, and cathode-ray tube, are all mounted on a panel and chassis of approximately the same size as the SX-28. Both units are installed in a metal cabinet with the Model S-35 Panoramic Adapter on top. (See illustration.) Only one electrical connection is made between the two units and the panoramic adapter does not interfere in any way with the normal operation of the receiver.

Before proceeding with an explanation of panoramic reception, it will be helpful to review the fundamental principles of the super-heterodyne. Fig. 1 is a simplified block diagram of a super-heterodyne communications receiver. Disregarding the panoramic adapter for the time being, the operation of the circuit is as follows:

Radio-frequency currents induced in the antenna are fed into the radio-frequency amplifier which is tuned to resonance at the frequency of the desired signal. The amplifier's output goes to the first detector or mixer which also receives the output of the high-frequency oscillator. As the first detector is a non-linear impedance,

the two incoming signals (radio signal and output of oscillator) combine, and the detector's output contains the original radio frequency, the oscillator frequency and the sum and difference frequencies of the two. In the SX-28, the high-frequency oscillator generates a radio-frequency current at a frequency 455 kc. different from that of the incoming signal (usually 455 kc. higher).

The intermediate amplifier is permanently tuned to a frequency of 455 kc. and therefore selects the 455-

kc. component in the detector output and amplifies it. This 455-kc. component has all of the characteristics, modulation, etc., of the original signal. For high-quality broadcast reception the intermediate-frequency amplifier is adjusted to pass a band of frequencies from 450 to 460 kc., with approximately equal gain. For communications work, in order to reduce interference, the pass band is made narrower either by coupling adjustments or the use of a crystal filter circuit.

Fig. 1. Block diagram of communications receiver with panoramic adapter.

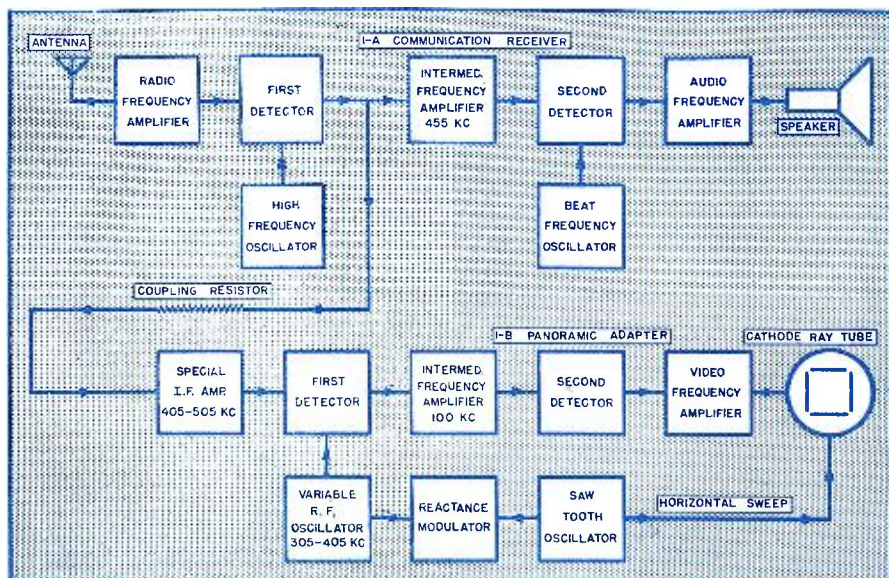

Schematic diagram, Hallicrafters S-35 panoramic adapter

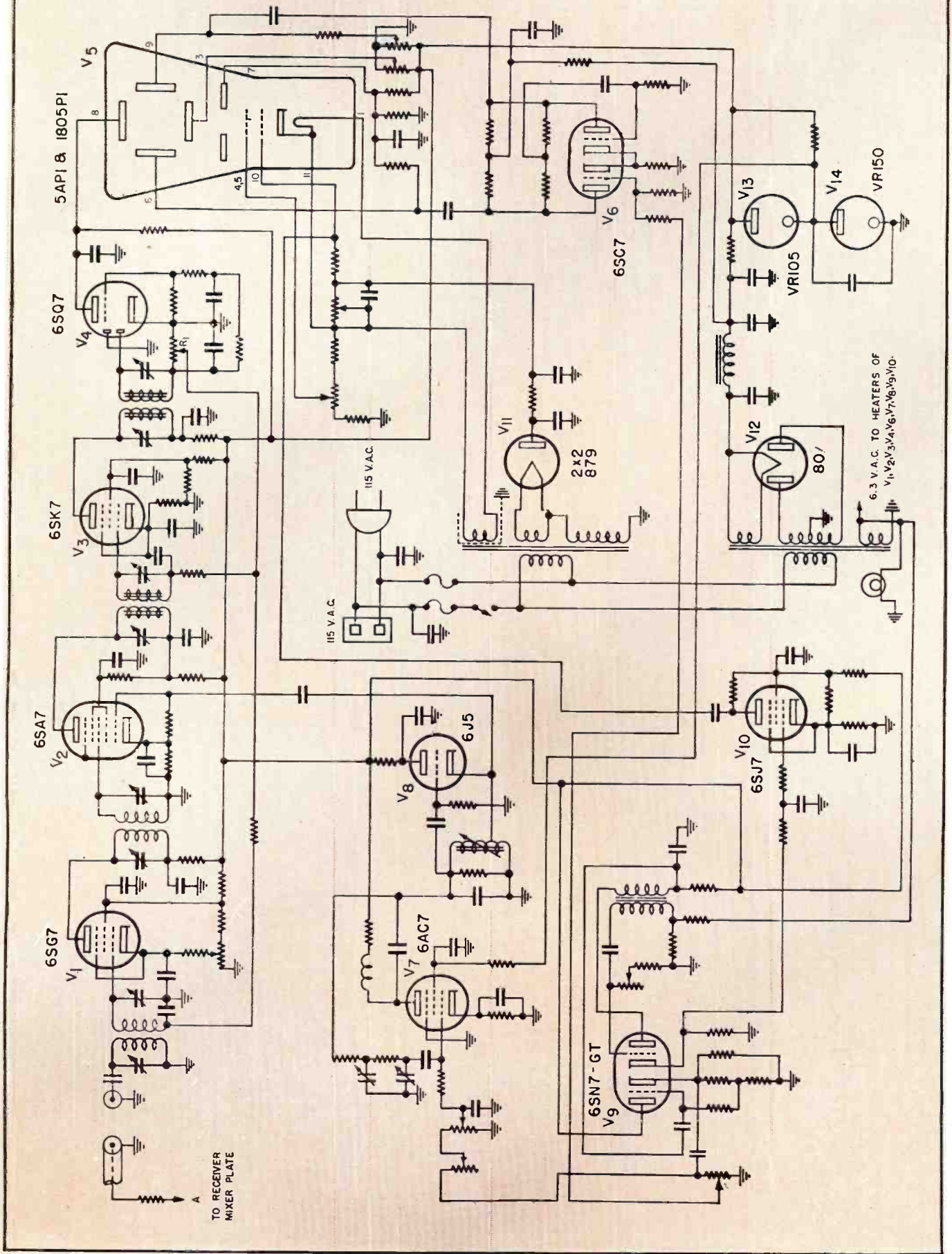

The output of the intermediate-frequency amplifier goes to the second detector where the audio frequency appears. In the case of phone or other modulated signal reception, the second detector acts as a rectifier and simply recovers the audio-frequency modulation of the incoming signal. When CW telegraph signals are being received the beat-frequency oscillator is turned on and adjusted to a frequency differing from the intermediate frequency by the desired audio frequency (usually 500 to 1000 cycles). The second detector combines the two frequencies and the resulting audio frequency is amplified again and then converted into sound in the loud speaker.

The panoramic adapter makes use of the super-heterodyne principle but its circuit operation is much more involved than that of the ordinary receiver. As can be seen from Fig. 1 a small part of the first detector output of the communications receiver is transferred to the panoramic adapter through a coupling resistor. This output is fed into a special 455-kc. I-F amplifier of unusual characteristics. As the panoramic adapter is designed to show all incoming signals within a range of 50 kc. on either side of the frequency to which the receiver is tuned, it is obvious that this amplifier must pass a band of frequencies 100-kc. wide. In addition it must provide greater gain in the outer portions of the band than at the center in order to compensate for the inherent selectivity of the radio-frequency amplifier and first detector of the communications receiver. Fig. 2 shows the selectivity curves of a radio-frequency amplifier and Fig. 3 is the approximate gain vs. frequency curve of the special intermediate-frequency amplifier in the Hallicrafters Model S-35 Panoramic Adapter. As shown in Fig. 2, the selectivity of a radio-frequency amplifier decreases with increasing frequency so it is impractical to compensate exactly over the entire range of the receiver. In the Model S-35 the special intermediate-frequency amplifier is designed for uniform compensation at an r-f signal input to the receiver of approximately 5 mc. At lower input frequencies, the selectivity of the receiver's R.F. and detector stages increases and as the amplification characteristics of the panoramic special I-F amplifier remain constant, the over-all gain at the output of the panoramic first detector is greater at the center of the 100-kc. pass band than at either edge. At higher input frequencies, the selectivity of the receiver's input circuits decreases and the panoramic input amplifier over-compensates with the result that the outer portions of the band have slightly higher gain than the center.

The output of the special intermediate-frequency amplifier containing all signals within a range of 50 kc. on either side of the signal to which the communications receiver is tuned is fed into the first detector of the

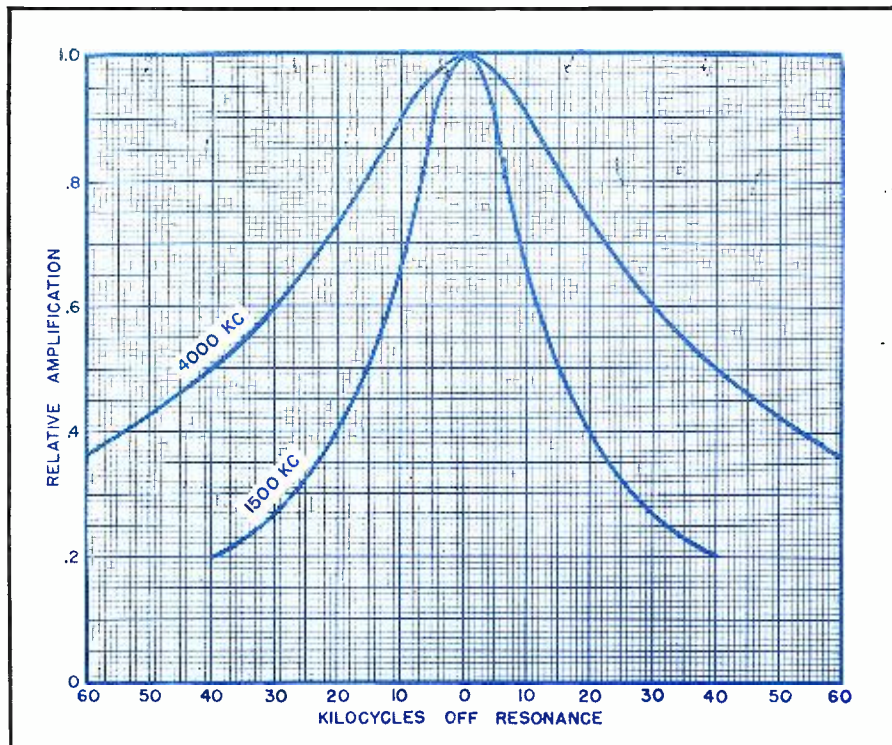

Fig. 2. R-F amplifier characteristics showing variations in selectivity with respect to frequency.

panoramic adapter. This detector also receives the output of the panoramic variable radio-frequency oscillator and combines the two, exactly as in ordinary super-heterodyne action.

At this point the principal difference between the panoramic adapter and the conventional super-heterodyne becomes apparent. In the ordinary receiver the high-frequency oscillator is designed for maximum stability; whereas, in the panoramic

adapter the oscillator frequency is constantly varied by means of a reactance modulator. The normal oscillator frequency is 355 kc. but under the control of the reactance modulator it continually sweeps across a band of frequencies from 405 to 305 kc.

The panoramic intermediate-frequency amplifier is sharply tuned at 100 kc. and has a band width of less than 2000 cycles. It is evident that
(Continued on page 64)

Fig. 3. Amplification vs. frequency characteristics of panoramic special I-F amplifier.

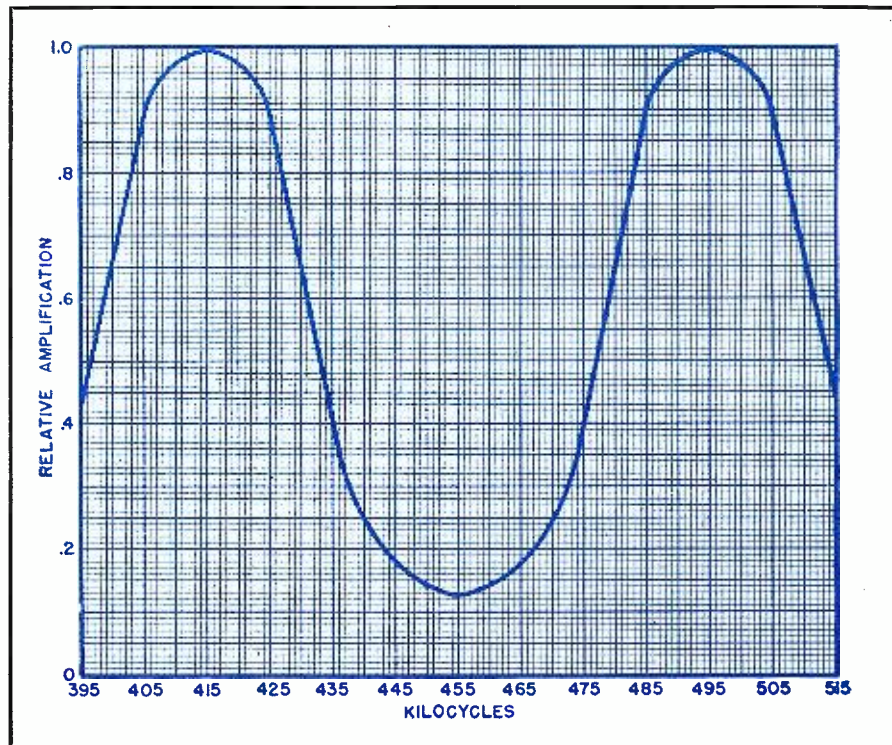

JUNGLE BROADCAST

A world-wide radio program prepared by our Armed Forces and transmitted from the interior of Central American jungles.

By GEORGE B. HILL

Panama Canal Zone

WHEN soldiers at a small Army broadcasting studio were asked to take their equipment into the jungle, arrange a 75-mile remote control circuit through some of Central America's most difficult terrain, and present a program to be heard around the world, workers at the Armed Forces Radio Station scratched their respective heads, and asked for a few days to think it over.

Panama Mobile Force was preparing the first world-wide radio program from Panama's jungles—a realistic picture of jungle combat training—and the problem dropped in the AFRS lap was so complicated at first glance that it seemed almost impossible. There could be no "boosters" on the 75-mile line. Jungle mud would prevent any wires being strung on the ground. Something might go out anywhere along the circuit. Explosions of mortar shells, bangalore torpedoes, or TNT might knock a line out or damage a microphone, for all

sound effects were to be the real thing.

It was almost like putting through a radio program on a prayer. Signalmen throughout the Department promised help and two days later, Mobile Force was notified that the Army's radio men were willing to try it.

When Sergeant Ewald Wyberg, engineer of the AFRS, began to check the coming 20-minute broadcast, he found troops were to go through two problems in a rugged Atlantic-side area. It was in the hilly and swampy Panama terrain, which does not have to play second fiddle to any jungle for being bad. Announcers were to describe the action on the spot—just as it happened. That was the only easy part of the broadcast, except that even the announcers were to find themselves slopping through heavy mud for almost a mile to complete their speaking parts.

The 75-mile setup was completed by Signalmen, co-operating with Wy-

berg, and on the day of the broadcast—November 14—soldier helpers carried about 600 pounds of equipment up a slippery trail to put it in position while Signalmen climbed through lush branches to make jungle phone poles of the tropical trees.

Five miles away, the second problem was to fill the program's remaining 10 minutes, beginning as the first ended.

Sgt. Wyberg took over Problem No. 1's technical end and Sgt. Jim Weathers, formerly with WAGF at Dothan, Alabama, took the mike. The broadcast from this area was to be made from a small hillside overlooking a maze of undergrowth, fallen trees and barbed wire entanglements facing three Jap-type pillboxes.

The second area was a swampy, mud-filled strip of dense undergrowth, vines and slush beside a tropical river, which had recently gone out of banks several times because of the rainy season, then in full swing. Here, expert Infantry swimmers were to make

Soldiers preparing for a combat stream crossing during broadcast.

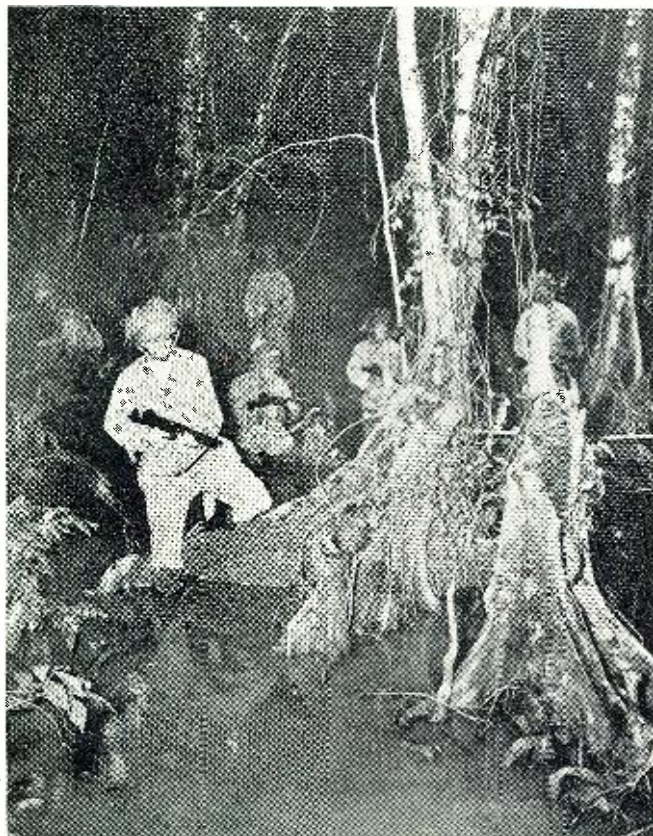

Announcers describe stream crossing made under simulated offensive.

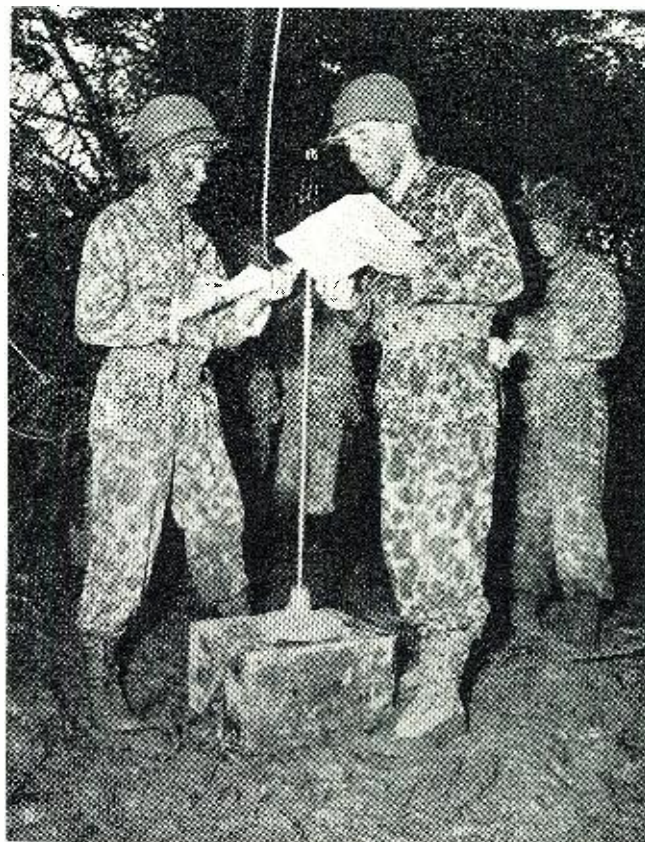



Announcer pinch-hitting at the controls.



Part of the equipment carried by the Panama Mobile Force Infantry and Engineer troops.

a stream-crossing assault on the opposite bank. Sergeant Charles (Chuck) Bras, who was radioing with KOMO and KJR at Seattle before that morning in December, 1942, when the President sent him "Greetings," stood in mud well above his ankles to make the description of the crossing.

2nd Lt. Mark Braymes, AFRS manager formerly with Mutual out of New York, crossed his fingers and predicted "our biggest flop or our biggest success."

Worrying over, everything went right—as right as things can go in a mass of mud and vines. Helpers brought heavy dynamos into place, after the portable power plants had been carried by truck for more than 50 miles. Amplifiers were packed down trails which one ex-southern farmer, now a Mobile Force jungle soldier, described as a "big pig pen," and beside swampy waters which ducks, wisely enough, have never been known to enter.

One of the chief problems, after the setup was made, was sound. There were to be no artificial sound effects. A crucial point in the program, however, brought out one which was unscheduled, but necessary. Weathers described the action: Mortar shells softening pillboxes; machine guns and riflemen opening up to drive the "enemy" into his hole and neutralize opposing fire; jungle troops preparing to move through the wire, bringing up a bangalore torpedo to blast the hole; Infantrymen pouring through. An engineer flame thrower and a pole-charge man crept toward the pillbox. The flames leaped toward their objective and the pole charge went into place. At this crucial point, Weathers paused. The charge failed to go off. Captain Robert B. Winkler, twice-decorated veteran of

(Continued on page 72)

Technical assistant at a remote outpost during the realistic training-maneuvers broadcast.

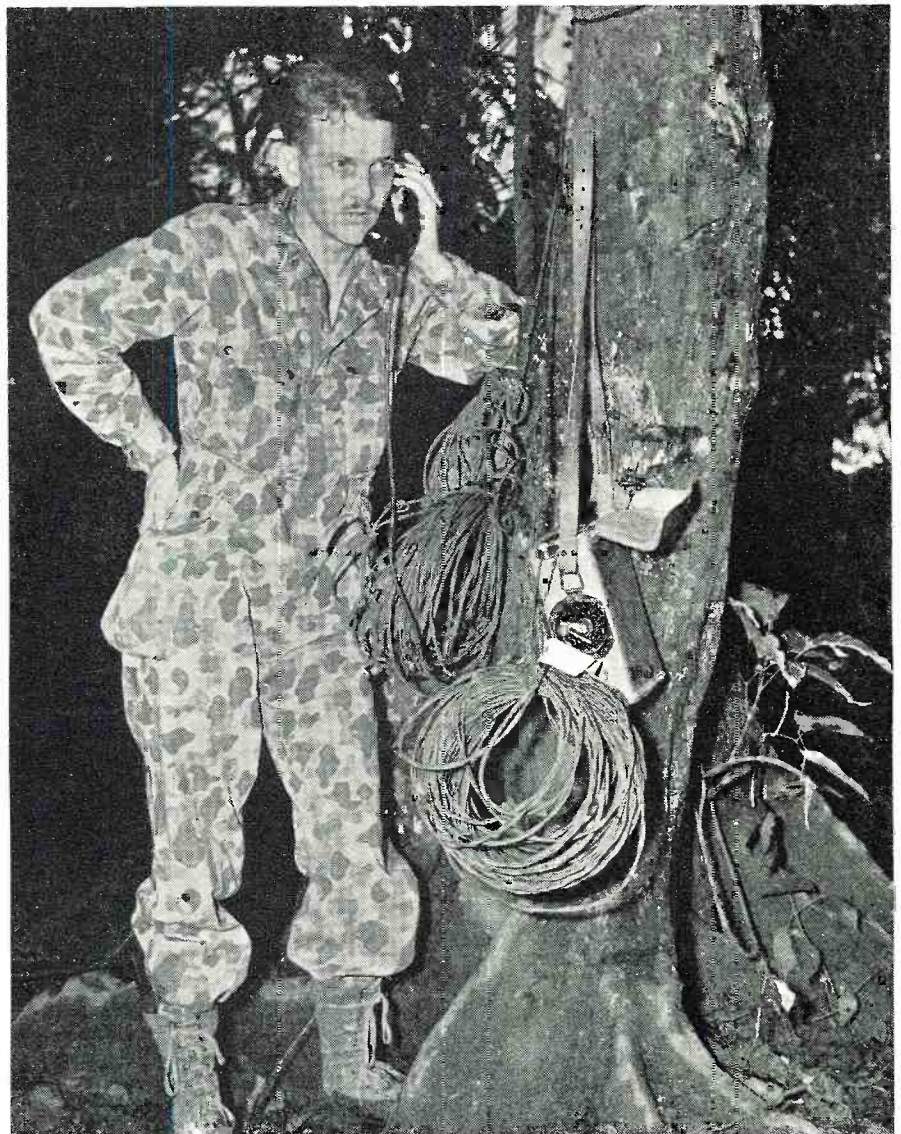

TECHNICAL BOOK & BULLETIN REVIEW

FUNDAMENTALS OF TELEPHONY, by Arthur L. Albert. Published by McGraw-Hill Book Company, New York and London. 374 pages. Price \$3.25.

This is an elementary book, intended for students and telephone workers, and is devoted exclusively to telephone communications. Because most of the readers will not have had extensive training in electricity, the first three chapters present basic electrical theory. The fourth chapter is devoted to sound, speech, and hearing. Much of the material in these chapters is taken from a previous book of the author's: "Electrical Fundamentals of Communication," and many of the illustrations, examples, and diagrams are from that book. Caution is advised to those who have read the previous book that although it is advisable to pass over these opening chapters, care should be taken not to overlook essential material, because much information pertaining directly to telephony appears in the first four chapters.

The following chapters consider such subjects as telephone transmitters, receivers, telephone sets and circuits, telephone lines, manual telephone systems, dial telephone systems, loading, telephone measurements, noise and cross-talk, and repeaters and carriers. At the end of each chapter are review questions and problems to assist the student.

THE TECHNIQUE OF RADIO DESIGN, by E. S. Zepler. Published by John Wiley & Sons, Inc., New York. 312 pages. Price \$3.50.

This book conveys to the reader some of the experience of a radio designer, obtained over a number of years in a large works laboratory.

It deals mainly with those problems which are closely linked with the daily routine work of an engineer, both in the development and testing of radio-receiving apparatus of all types. Intimate details of many aspects of receiver work are given rather than a comprehensive treatment, general principles being left to textbooks.

The technique of experimental work begins where unexpected complications occur; where a circuit behaves in a manner not predicted from the circuit diagram. On the other hand, the technique of design consists in foreseeing these complications and being able to work out on paper the electrical circuit and mechanical construction, so that serious trouble is not likely to occur. The principal aim of this book is to develop qualities necessary for such work, i. e., a feeling for the right order of magnitude, a quick grasp of essential facts and common sense in approaching the problems.

(Continued on page 113)



By **CARL COLEMAN**

THE first "Victory" ship of the United States Merchant Marine, the start of a fleet which is expected to become the mainstay of the postwar cargo ships, was launched in January at the Oregon Shipbuilding Corporation operated by Kaiser. The new vessel christened "United Victory," is more rakish and faster than the "Liberty" ships, making about four knots more; carrying capacity is about the same as that of the production line products. The new vessels will make a round trip across the Atlantic in about three weeks as compared to the Liberty's time of nine weeks. The Victory will of course, however, be slower in construction, taking much longer than the usual thirty days consumed in the construction of the Liberty. We have not, as yet, seen the layout of the radio shack on this type vessel, but at least it will be an improvement over the Liberty type, we sincerely hope—with all the complaints that came in from the older models better rooms and conditions should be found. The Liberty with the "mill" on the wrong side, poor ventilation, lack of heat in cold weather, and other difficulties certainly received its share of objections from the boys.

R. McWHIRTER and M. Tilley sailed recently on tankers from

the East Coast. Leif Bye took out another cargo job from an Atlantic Coast port after an extended vacation ashore. A. J. Gashett is also out on a freighter, a new assignment. Bob Lacey is in from a short tanker trip after his short stay ashore. H. O. Andersen went out on a tanker also recently, likewise H. Rautersen. H. Harris is still sticking to his cargo job where he has been for over three years.

MANY inquiries regarding entering the U. S. Maritime Service have been received so the following information may be of some help to those wanting to get into this outfit and take their radio training course. First off, Maritime reports that the only school now open is the one at Gallups Island up in Boston Harbor; the pre-training school at Huntington, Long Island has been closed. Formerly students were sent to Huntington for a short course which was followed by five or six months at Gallups Island for finishing off before spending a few days in the local FCC offices to get that ever so essential "ticket."

New course entirely at the "Island" school in Boston is about seven months on the average, as reported by the Maritime Service, N. Y.

The U. S. Maritime Service is looking for men 18½ years of age to 37½ years of age for these training courses and will not accept you unless you are within these age limits. A man is assigned a station for five weeks, after which he is given an aptitude test. This examination is competitive and those with the highest marks are assigned to the school to the extent of its capacity. Others are assigned to other branches of service. There is, in other words, no guarantee that you will be in radio training, or, for that matter, assigned to radio in any case. It's a case of the best man winning.

(Cont'd on page 106)



THEORY AND APPLICATION OF U.H.F.

by MILTON S. KIVER

Part 3. Fundamental theory and operation of the transit-time and negative-resistance magnetron ultra-high frequency oscillator tubes.

IN ORDER to appreciate the mechanism of the magnetron, several ideas must first be developed. As is well known, the electron travels to the plate of a tube when the potential applied to the plate is positive. Its path in this case usually is a straight line, this being the shortest distance between the cathode and the plate. The electron will be attracted to the plate whether the electron is at rest or in motion.

Now let us consider what happens to an electron when it is in motion and only a magnetic field is present. If the motion of the electron carries it

If now we come to the situation found in the magnetron where the magnetic and electric fields are usually at right angles to each other, an electron travelling in this combined field with some of its motion at right angles to the magnetic field will describe a helical path. This type of path can best be visualized if one imagines the electron as travelling in a circle and at the same time also moving forward. The best mechanical device that describes this type of motion is a screw being put into a wooden board. Its motion is circular, yet it is always moving forward.

In the magnetron the electron is emitted by the filament and is attracted to the plate. However, due to the magnetic field present it describes a path such as is pictured in Fig. 2. As the value of the magnetic field increases the electron describes circular paths with decreasing radii, until finally the electron no longer hits the plate and the plate current stops. It is at this point in the phenomenon that the magnetron becomes useful as will be described in the following paragraphs.

Having shown what a magnetic field of force can do to an electron, a review of the principles and circuits of a type of ultra-high frequency generator known as the magnetron may be given. The device called the magnetron by Hull was developed in 1921. As first used it consisted of a cylindrical plate structure and a coaxial filament, with a uniform magnetic field directed along the electrode axis. The magnetron most widely in use today differs from the above only in having the plate structure split lengthwise in two and appropriately called the "split-anode magnetron." The field set up by the magnetic coil is usually constant in value although alternating magnetic fields have also been experimented with. The best results, however, are received with the steady field.

The magnetron used as an oscillator can be divided into two types—one is the type known as the negative-resistance magnetron oscillator and the other is the transit-time oscillator. The negative-resistance magnetron, or dynatron magnetron as it is sometimes called, actually operates for a portion of its characteristic curve as a negative resistance and hence, will sustain oscillations. Its action is somewhat analogous to the tetrode where

the plate current actually decreases for small increments of its plate voltage. The frequency of the negative-resistance magnetron oscillator is less than the second type—the transit-time oscillator. In the transit-time oscillator the frequency of oscillation is determined by the vibration of the electrons between the filament and the plate segments.

The Negative-Resistance Magnetrons

The basic idea of the negative-resistance magnetron was brought out by

Fig. 2. Electron path from cathode to plate in a magnetron tube. (a) With weak magnetic field causing circular electron path. (b) Increased magnetic field. (c) Strong magnetic field preventing electron from reaching plate.

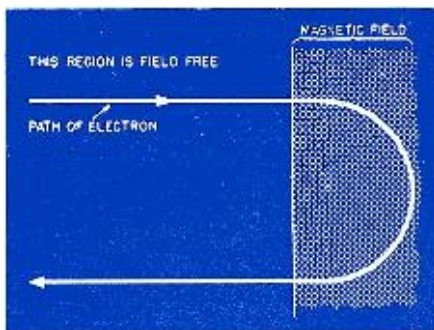
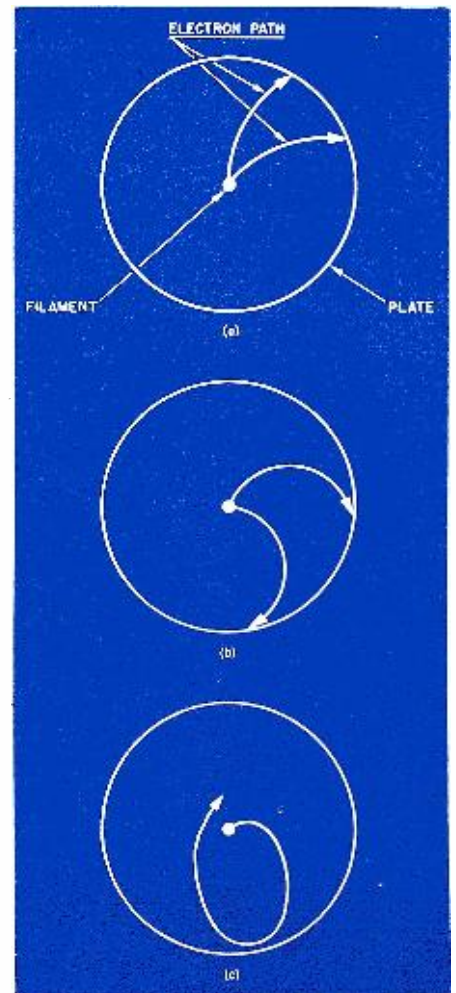

Fig. 1. Path of an electron as it is projected into a magnetic field.

parallel to the lines of flux of the magnetic field, then the magnetic field will exert no force whatsoever on the electron. If the electron is at rest then the magnetic field will exert no influence on the electron and it will remain at rest. However, if the electron velocity has some component normal to the lines of flux of the magnetic field, then the electron will be acted on. Referring to Fig. 1, suppose the electron enters the magnetic field at right angles to the field. Then the force acting on the electron will cause it to travel in a circular path. In the case chosen, it left the magnetic field before it could complete the circle, but if the entire space were under the influence of the magnetic field, the path of the electron would have been a true circle. It can be shown by simple considerations that the radius of the path is directly proportional to the speed of the particle. Furthermore, the period and the angular velocity are independent of speed or radius. This means that faster-moving particles will travel in larger circles in the same time that a slower moving particle moves around its circle.



Habann in 1924 and the arrangement shown in Fig. 3 was developed by Manns in 1927. In the figure it can be seen that each tuned circuit (there are really two) is placed between the filament and a plate segment. Although the tuned circuit shown consists of a coil, condenser and the inherent resistance of the circuit, actually a Lecher-wire system is used since ordinary coils and condensers are pretty nearly useless at the ultra-high frequencies. In order to start oscillations the magnetic field is increased to slightly above the point where the electrons just graze the plate. The first value at which the electrons miss the plate is known as the critical value. The formula usually given for the critical magnetic field is:

$$H_c = \frac{6.72}{R_p} \cdot \sqrt{E_p}$$

where:

- R_p = plate radius in centimeters
- E_p = plate potential in volts.

Once oscillations have been started, the value of the magnetic field is not critical and may be varied over a wide

range. The oscillation frequency is essentially determined by the natural resonant frequency of the external tuning system. In order to obtain good efficiency with this type of oscillator the electron transit time should be kept to 1/10 or less of the oscillating frequency. This is also true for ordinary negative-grid triode oscillators. The importance of these negative-resistance oscillators is due to their large power output and high efficiency even at fairly short wavelengths. It has been reported that using air-cooled tubes, power outputs of the order of 50 watts or so, has been attained at a wavelength of 50 centimeters and when water cooling of the tube was resorted to, several hundred watts of power output were obtained with an efficiency between 40 to 55 per cent.

Referring again to the oscillator, let us see just how a negative resistance is obtained. The explanation can be found by referring to the volt-ampere or static characteristic curves of the split-anode magnetron shown in Fig. 4. These curves can be obtained experimentally by increasing the poten-

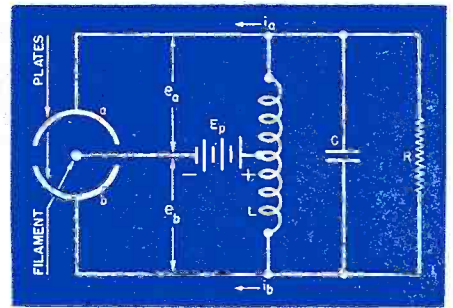

Fig. 3. Diagram of a split-anode magnetron tube. Note resemblance to the ordinary push-pull amplifier circuit.

tial of plate A by small amounts and, at the same time, decreasing the potential of plate B by a corresponding amount. In this way conditions similar to actual operations are obtained. When the currents to the plate segments (in this case i_A and i_B) are measured, it is found that more current flows to plate B than to plate A even though plate B is at a lower potential than plate A. Furthermore, as this difference between plate potentials ($E_A - E_B$) is increased, up to a certain point, the excess of current to plate B increases. And when we plot the current $I_A - I_B$ against the potential $E_A - E_B$, we get the curves shown in Fig. 4. The portion of the curve shown as O P represents the negative resistance because the current increases as the potential decreases. It is this negative resistance that is responsible for the sustained oscillation. Fig. 5 shows the instantaneous potentials on the two plate segments during one complete cycle of oscillation.

The reason for the peculiar behavior of the electrons in going to the plate of lower potential instead of to the other plate can be found only when the field due to the electric and magnetic forces in the tube are analyzed. It is due mostly to the magnetic force present, since removal of this field would force all the electrons to go to the plate of higher potential.

It must not be thought that the negative resistance is due to one plate alone. While it is true that the characteristic curves shown in Fig. 4 state that the voltage on one plate is increasing while on the second plate it is decreasing, it must be remembered that this is true only during one portion of the cycle. During the next portion of the cycle, the reverse is taking place and so now the opposite plate is exhibiting this negative-resistance characteristic. For those readers who may have trouble visualizing this process, reference to any ordinary push-pull amplifier will clear up this matter. Incidentally, these static curves can be used to calculate power output, efficiency and load resistance needed.

To visualize what the electrons actually do in the tube, reference is made to diagrams and a photograph published by Kilgore, which are shown in Fig. 6. In Fig. 6a, the potentials of the two plates are equal and the mag-

Fig. 4. Static characteristics showing negative resistance of a two-segment magnetron. Courtesy of D. Van Nostrand Co., Inc.

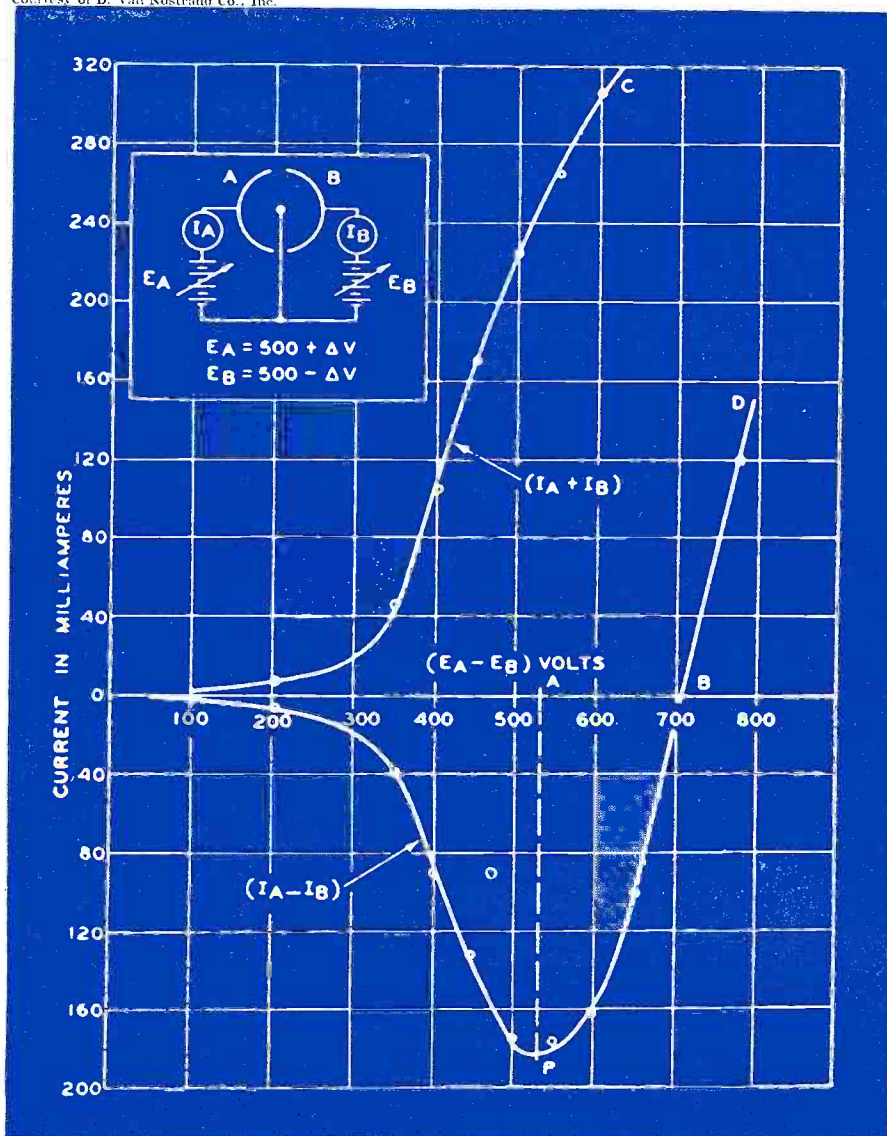

netic field is beyond the critical value. Here the electrons describe circular paths and as can be seen, none reach either one of the plates. In Fig. 6b and c the voltage of one plate has been increased while on the other it has been decreased. Now the electrons describe more or less complicated paths finally ending up at the plate of lowest potential. This point would not have been immediately obvious and is only due to the *strong* magnetic field. In Fig. 6d, a special gas was introduced which did not have any effect on the path of the electron, but nevertheless, made it visible. The photograph clearly substantiates the previous line of reasoning.

As the frequency of oscillation desired is raised, then the same troubles that one runs into with the ordinary negative-grid oscillators is encountered here. The main fault is again due to transit time. This can be overcome in part by either high plate voltage or small plate diameters. Included also, of course, is the much stronger magnetic field that must be used. As plate size is decreased, the allowable plate dissipation must be lowered and consequently, decreased power output. It is due to these limitations that again turned experimenters to using this device operated on the transit-time principle, or, to put it differently, to utilize transit time to advantage.

Transit-Time Magnetrons

The other class of magnetrons that is used for the very short wavelengths operates at frequencies determined by the electron transit time. As far as is known today, these oscillators and those described in the chapter on Klystrons are the only two used to generate the extreme high frequencies. It was about 1924 that the first mention was made of the magnetron using the transit-time principle to generate oscillations. In 1928 Okahe showed that the wavelength that could be obtained was dependent on the magnetic field used and given by the formula:

$$\lambda = \frac{12,000}{H \text{ (gauss)}} \text{ centimeters}$$

The same tube that is used for the negative-resistance oscillator can also be used for this type with a few changes in the operating conditions. From the formula given above it can be seen that the magnetic field

Fig. 5. Alternating potentials on the plates of the split-anode magnetron.

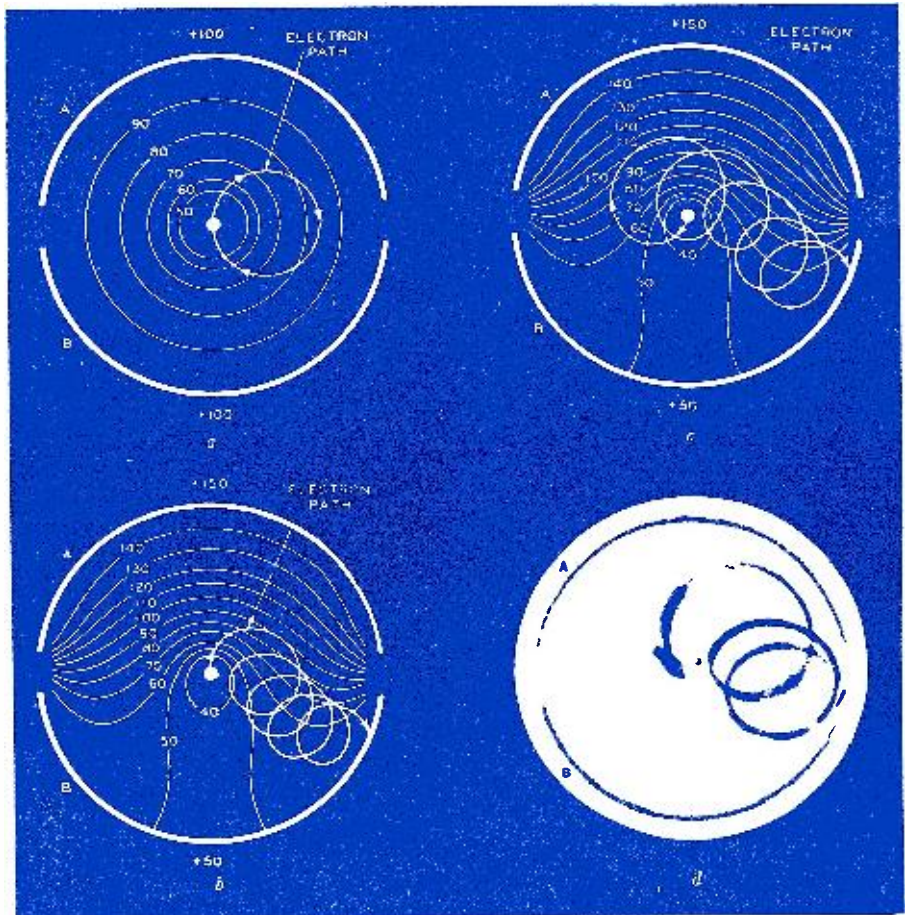
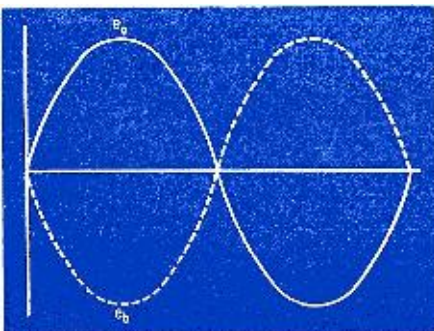

Fig. 6. Typical electron paths in a two-segment magnetron showing how electrons arrive at the lower potential plate-half. (d) Photograph of ionized path of electrons in a gas-filled tube.

strength is critical in adjustment because the wavelength is dependent on it. At the same time this magnetic field should be adjusted near the critical value so that the electrons will not hit any of the anodes. Plate voltage will also have an effect on the radial motion of the electrons and must similarly be quite finely set at the correct value. In addition to all of the above, it was found that for optimum results the magnetic field should be slightly inclined to the tube axis. This inclination is never more than a few degrees.

The mechanism of the transit-time magnetron is in many respects similar to the positive-grid oscillator previously described. However, in order to keep this discussion complete, the theory will be given here separately. In the operation of all magnetrons the magnetic field is adjusted so that the electrons just graze the plate as shown in Fig. 2. Now, suppose a small alternating voltage is superimposed onto the direct voltage already applied to the plate. Any electron leaving the cathode when the alternating voltage is going positive will be given a greater acceleration than had the a-c voltage been zero. Hence, this electron will probably hit the plate with the excess energy absorbed from the alternating voltage source. Since this electron absorbed energy it is imperative that it be removed as soon as possible. The object, as stated before, is for the al-

ternating source of power to absorb energy, not lose it. This is the only way to sustain oscillations.

An electron that leaves the cathode a half cycle later will not approach as close to the plate as when the plate voltage was constant. This means that energy must have been given up by the electron to the source of alternating voltage since without the superimposed a-c fluctuations the electron ordinarily would have had enough energy at this point to keep on going. On its return trip the electron will not quite reach the cathode because now the plate is going positive and the attraction for the electron is greater than it ordinarily would be. The electron can continue to oscillate back and forth with decreasing amplitude and to deliver energy to the source of alternating voltage until it comes to rest at a point between the anode and the cathode, or is removed from the interelectrode space because of its sideward motion. It should be kept in mind throughout this entire discussion that the reason the electron moves to the plate and then swings back to the cathode is due entirely to the fact that there is a magnetic field present which tends to force the electron to move in a circular path. Without the magnetic field none of this action would be possible. Fig. 7a shows the motion of an electron that absorbs energy from the a-c source. Fig. 7b shows the path

(Continued on page 58)



ELECTRONIC INDUSTRY

Checking mount mechanism of cathode-ray tubes in an air-conditioned, dustless room.

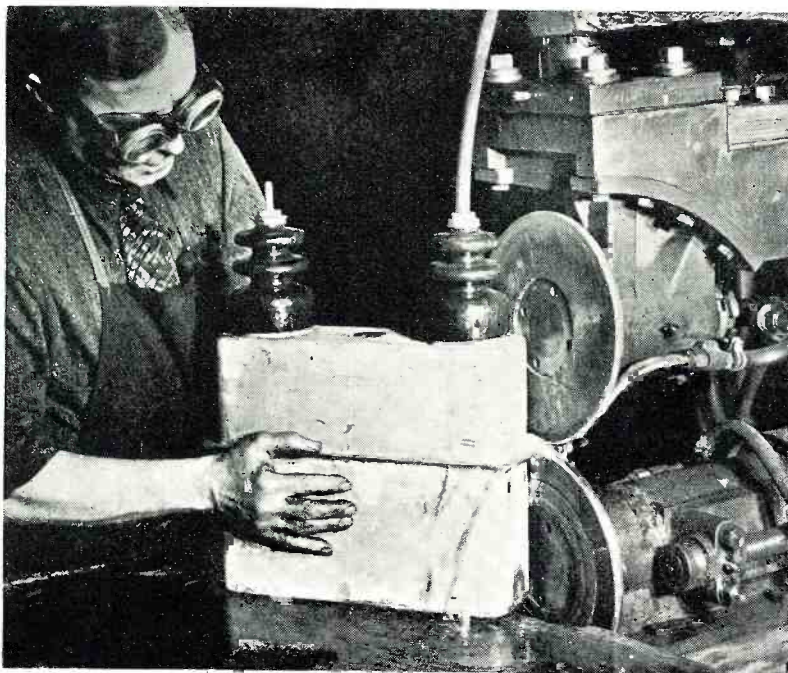

Operator is using a thyatron-controlled resistance welder to join two halves of a pyranol unit case.

AMERICAN industry's adaptability is again illustrated in its many uses of electronics. War needs have developed many new devices, inventions, and techniques, which already indicate wide application in the postwar era. Electronics will be found doing its job everywhere—in many industries. The steel industry, with its huge castings weighing many tons, will be assisted by the application of new and outstanding electronic X-ray machines. The plastic industry which will see great expansion in years to come, will be aided by pre-heating with electronic heat generators. Imagine the wonders of the modern home of tomorrow, with its electronic equipment, from the television set in the living room to the electronic oven in the kitchen. It is known that every possibility, indicated by wartime research, will be fully developed by industry for peacetime use.

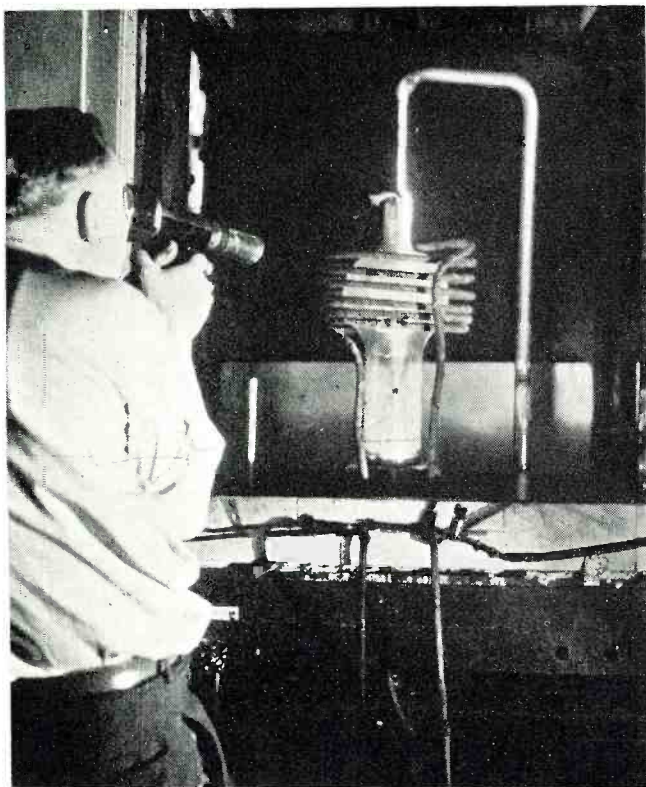

Universally-used pyrometer in operation—measuring the temperatures of various elements of an electronic tube.

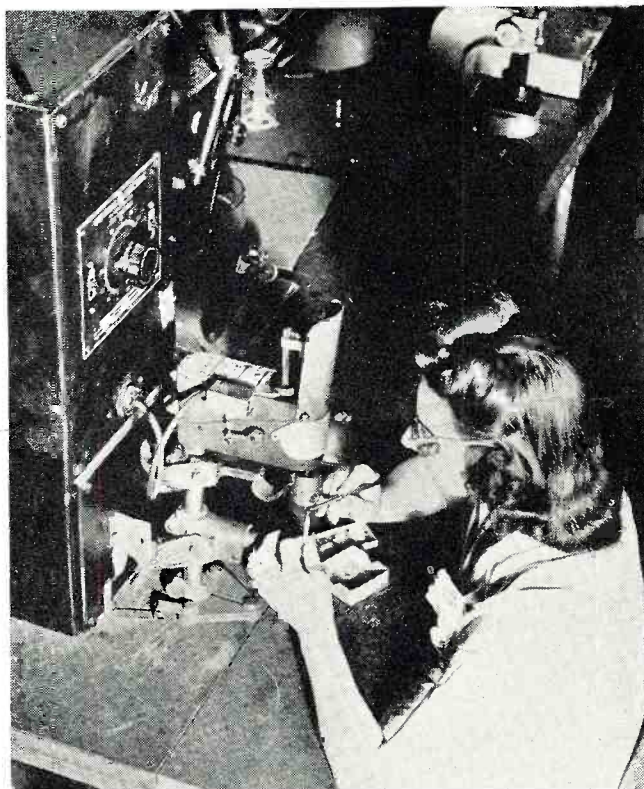

A thyatron half-cycle welding control panel used with bench units for spot welding vacuum-tube assemblies.

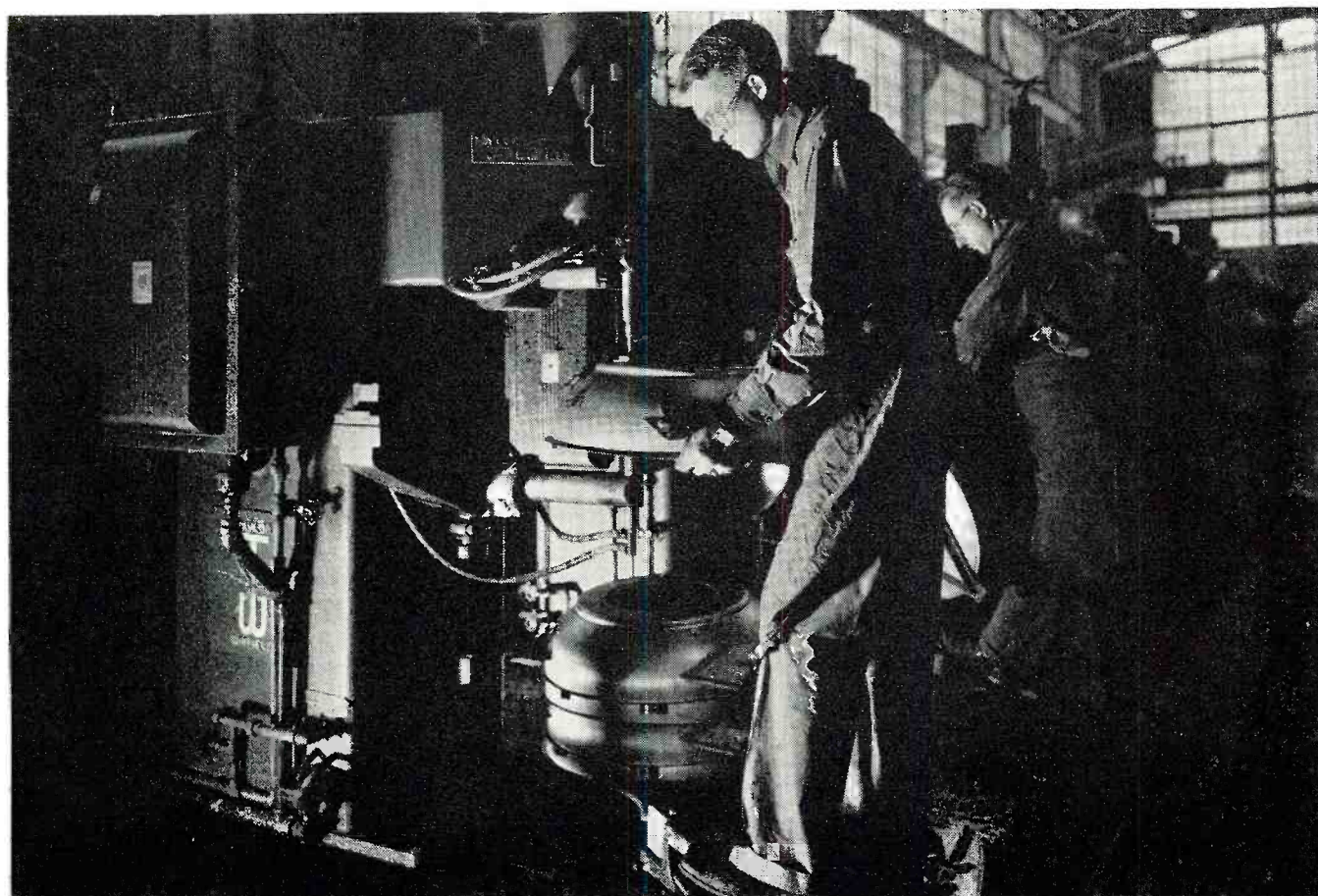

Electronic tubes serve as power switches for these resistance welders. Brackets of enamel stock are spot welded to housings by means of air-operated machines using an electronic contactor.

Manufacturers' Literature

Our readers are asked to write directly to the manufacturer for this literature. By mentioning RADIO NEWS and the issue and page, we are sure the reader will get fine service. Enclose the proper sum requested when it is indicated. This will prevent delay.

FACTS ABOUT PLASTICS

A new, twenty-four page, non-technical booklet covering all types of plastics, their uses, and general information on the plastics industry has just been released by *The Richardson Company*, Melrose Park, Illinois.

This illustrated book explains the host of properties which fit INSUROK and other plastics to the wide range of present and postwar uses. The limitations of plastics are also covered.

The two main groupings of plastics, Thermosetting and Thermoplastic, are described and illustrated in layman's language. Special sections are devoted to the forms of plastics, laminated and molded. The manufacturing and production processes of each are well illustrated.

The book is designed primarily for the non-technical man who may be serving on his company's postwar product committee and is desirous of obtaining a general knowledge of plastics and their applications. Copies are available only to those who write for them on their company letterhead to: *The Richardson Company*, Department 100, Melrose Park, Illinois.

TIMING DEVICES

An attractive new catalog covering various synchronous timing control mechanisms, has been released by *Haydon Mfg. Co., Inc.*

The broad range of special timing devices, tailor-made to the customer's requirements, includes improved designs of repeat and interval timers, time delay relays, contactors, interrupters, instrument clocks, elapsed time indicators, and other electrical apparatus for almost every conceivable timing application. Complete descriptions are given of each unit, and the catalog is profusely illustrated with photographs and dimensional diagrams of the devices.

Copies of this catalog may be had by writing directly to *Haydon Mfg. Co., Inc.*, Forestville, Connecticut.

RESISTANCE WELDING

An attractive 46-page booklet, consisting for the most part of published articles by *General Electric* engineers on the circuits and operation of electronic controls for resistance welding, has been published by the *General*
(Continued on page 109)

THE SITUATION TELEVISION

By PHIL GLANZER

The future of television and the effect it will have on our economic conditions and social lives

ONCE again the world looks to science to supply it with a new industry, and, as the radio and motion pictures have proved possible, a new, vital force to aid in economic recovery and advancement. That invention which science is holding up its long sleeve is television.

The day of television is nearing. Before the war, England and Germany were both planning television on a large scale. A new television station was being built at Alexandria Palace in London.

In the United States, despite wartime conditions, active research and experimentation is proceeding behind the scenes with television programs. Canada, too, is participating with experimentation. A score or so of corporations and independent workers are hard at it on the North American continent—seeking to master the technique of sending pictures through the air or by wire. Thousands are experimenting with receiving apparatus and helping to perfect this startling new science—just as they “pushed” radio along.

But for the past few years we have heard much talk of postwar television—literally—in the air. We have heard wild promises and rash statements—that television would be “here as soon as the war is over,” or “it would never be completely perfected.”

These various contradictory statements have puzzled many—and occasional premature exhibitions of television sets have weakened the confidence of many in the final perfection of television. Many wonder as to just where television stands today—in the laboratory—and also wonder as to its possibility and proximity for use in the home and movie theater.

There are two problems facing television. One is technical—the other is financial. As engineers approach solutions to the technical questions, industrialists gasp at the cost of future television. As the technician gets ready to place television at the service of the public, the manufacturer and merchant are appalled at the apparent costs of an “image service.”

There can be no gainsaying the fact that television has made huge advances—in the laboratory—in the last three years. Although few realize it, right on through the last depression, hundreds of thousands of dollars have been invested in the developing of television apparatus.

Large corporations, including the Radio Corporation of America, the American Telephone and Telegraph Co., Philco Radio and Television Co., and a host of independent companies have kept their scientific noses at the grindstone and are gradually perfecting television. The financial problems,

which we will discuss later, are important—but can be, and will be, surmounted.

But let us understand that television will affect all of us quite directly. It will change our economic conditions, our social lives and even the educations of our children. Just as the general introduction of the auto and radio aided industry by furnishing thousands of jobs to mechanics, entertainers and salespeople, television will do the same.

Like the auto and the radio, it will bring the country closer to the city. It will remove the last vestige of country isolation. Just as the car has brought the country to the city and as radio has made Europe's news ours
(Continued on page 61)

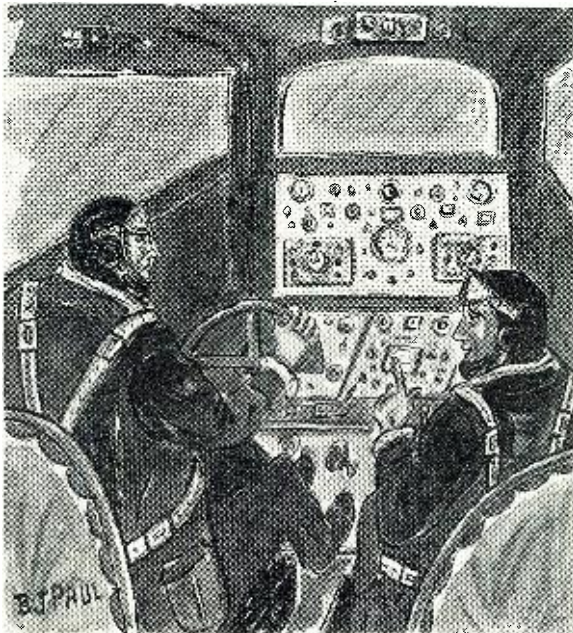

“THIS complicated? Say, you should see my radio-servicing test bench back home.”

PRACTICAL RADIO COURSE

by ALFRED A. GHIRARDI

Part 21. Continuing the study of inverse feedback and the benefits that may be realized from its use in amplifiers.

THE ratio E'_o/E_o represents the effective over-all gain obtained when inverse feedback is employed (see Fig. 1) and is equal to:

$$\frac{E'_o}{E_o} = \frac{A}{1 + \beta A}$$

This equation is a very important one for inverse feedback calculations. To illustrate its application, suppose that 25 per cent inverse feedback is applied to an amplifier whose voltage amplification is 100. The effective over-all gain will then drop to:

$$\frac{A}{1 + \beta A} = \frac{100}{1 + (.25 \times 100)} = 3.85$$

Examination of the gain equation reveals that as the feedback voltage, β , is made larger, the over-all gain of the amplifier system is reduced, and when β is made quite large compared with unity, the equation for the over-all gain reduces to:

$$\frac{E'_o}{E_o} = \frac{A}{\beta A} = \frac{1}{\beta}$$

This represents the condition of affairs for true inverse feedback working. Expressed in words, this equation states that with large amounts of feedback the over-all gain of the system is almost independent of A , the amplification of the amplifier proper. This quite remarkable characteristic of feedback amplifiers results from the fact that when the feedback is large, the net signal voltage actually applied to the input grid represents a small difference between relatively larger signal and feedback voltages. Even a moderate change in the amplification A therefore produces a large change in the difference between the signal and feedback voltages, thereby altering the actual input voltage in a manner that tends to correct for the variation in amplification. It follows from this that if anything happens to change the amplification A (power supply voltage variations, or tube replacements, etc.) the change in output is much less in amplifiers where inverse feedback is employed than where it is not present.

In accordance with the foregoing, if, say 25% ($1/4$) of the output voltage is fed back to the input, then the effective over-all gain is approximately $1/1/4 = 4$, provided that the product βA is large compared with unity. This checks with the value obtained in the example stated earlier.

Actually, it is this proviso which constitutes one of the limitations of feedback amplifiers. Let us take, for example, an amplifier with a normal gain of 1,000. In this amplifier, for

the product βA to be large compared with unity, β must be of the order of 0.01 to 0.005. If β is 0.01, however, the gain of the amplifier is only 100, so that we have obtained our inde-

pendence a corresponding amount, and the feedback decreases. This causes a positive change in grid potential, resulting in a decrease in the plate current. Now a plate-current increase as a result of a plate-voltage decrease is equivalent to saying that the effective internal plate resistance has decreased. Thus we say that the inverse feedback reduces the a.c. internal plate resistance of the tube. The effect is similar whether the feedback is taken to the grid of the final tube or to some earlier point in the amplifier, provided that the gain reduction factor is constant.

The new value of the internal plate resistance amounts approximately to dividing the plate resistance of the

tube by $\mu\beta$. Since $\beta = \frac{R_1}{R_1 + R_2}$ (see

Fig. 1), this expression reduces to $\frac{\mu R_1}{R_1 + R_2}$. Since μ for a typical power

amplifier pentode may be of the order of about 600, if a ratio $R_1/(R_1 + R_2)$ equal to about 1/6 is used, the apparent plate resistance of the tube when feedback is used will be only about 1/100 of its normal value. The importance of being able to cause so great a reduction in the apparent plate resistance of a tube by applying such a nominal value of inverse feedback to it is evident. Simply by applying the proper amount of inverse feedback in this way to power amplifier stages that employ tetrode, pentode, or beam power tubes which normally have a very high plate resistance of the order of several hundred-thousand ohms, their plate resistance can be made very low, making them assume the desirable characteristics of low- μ triodes, yet retaining their moderate bias voltage requirements and a large part of their superior power sensitivity—all at the

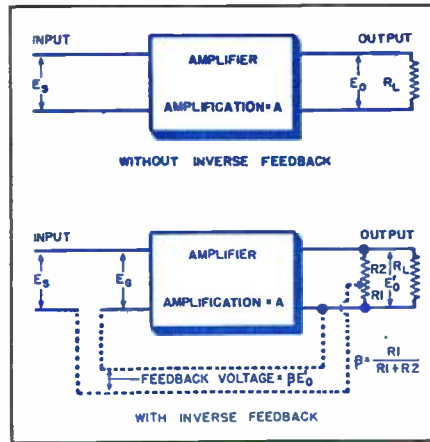

Fig. 1. Circuits used to show how inverse feedback is applied in amplifier circuits and to calculate over-all gain.

pendence of tube and circuit conditions at the expense of 9/10 of the gain. Of course, in most cases the input level to the stages comprising the feedback loop may be raised by the use of additional amplification to compensate for this.

Effect of Inverse Feedback on Tube Plate Resistance

One of the most important effects produced by the use of inverse feedback voltage that is proportional to the output voltage, is the enormous decrease it causes in the apparent a.c. plate resistance, r_p , of the amplifier tube from which the feedback is derived. The internal plate resistance of the tube is not actually changed by the feedback. If the plate voltage rises, the voltage across the load de-

Fig. 2. Voice-coil impedance variations of dynamic speaker over audio-frequency range.

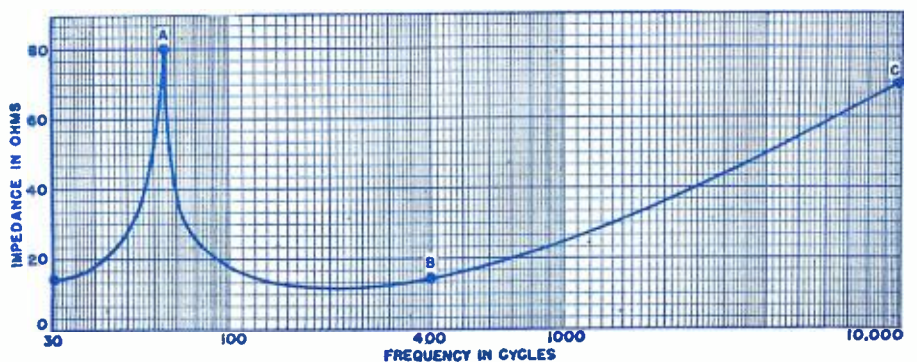

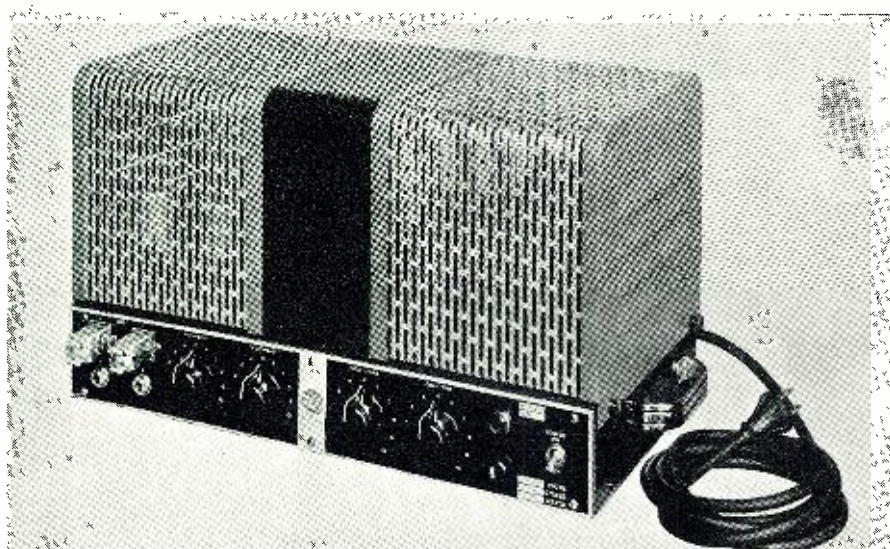

25-watt amplifier incorporating inverse feedback to reduce hum and improve tonal quality.

cost of no more than a moderate reduction in the high gain. It is actually possible, in this way, to make the plate resistance even lower than that of a low- μ triode without feedback.

One of the direct benefits of the low effective plate resistance that can be obtained for pentode and beam power tubes lies in the fact that it provides a high degree of damping effective in reducing low-frequency "hangover" and "boominess" caused by the resonance effects present in the loudspeaker at certain frequencies, and which is so frequently present when pentode and beam-power type tubes are used in non-degenerative circuits. The property of low plate resistance is also of value when a tube forms the terminating resistance of a filter.

Although the apparent plate resistance of the output tube is greatly decreased by inverse feedback, the plate load required by it insofar as maximum power output is concerned is the same with or without degeneration.

To match the internal impedance of the output tube to the load resistance with which maximum power output is obtained, so that best performance will result, most pentodes should be degenerated so that the impedance (looking back into the tube) will be approximately 7000 ohms. Beam power tubes, such as the 6V6, should be degenerated so that their impedance will be approximately 5000 ohms. These values will be sufficiently low also to insure adequate damping of the speaker voice coil resonances.

The normally high plate resistance of pentode and beam power tubes is unsuitable from another important viewpoint—that of the amount of low-frequency distortion which may be tolerated. This low-frequency distortion is not due to the characteristics of the tubes (which remain unchanged regardless of frequency), but depends upon the magnetizing current in the output transformer.

The magnetizing current is a distorted non-sinusoidal wave and this current, on flowing through the high plate resistance of the tube, develops a non-sinusoidal voltage drop across the tube which, when subtracted from the input signal, results in a distorted wave across the output. Unfortunately, it has become a practice to measure most amplifiers for distortion at 400 c.p.s. where the magnetized current is practically negligible. It is not uncommon to find beam power amplifiers without inverse feedback which have only 25 per cent of the rated power at 40 or 50 cycles. This low-frequency distortion is particularly objectionable since all harmonics fall within the audible range. Inverse feedback effectively reduces the plate resistance so that the distorted voltage drop caused by the magnetizing current is exceedingly small, with the result that there is very little distortion across the output circuit. With a poor output transformer it is quite possible for the distortion to be as high as 30 per cent at 40 cycles without inverse feedback.

How Inverse Feedback Improves the Output Regulation

Another beneficial result of the decrease in the apparent a.c. plate resistance of the tube by inverse feedback action is that it automatically compensates for changes and wide variations in output load; that is, the output voltage from the tube is made relatively independent of the load impedance. This is easily explained. If we imagine an amplifier to be feeding a certain load resistance, and then that load resistance to be reduced through any cause, the output voltage will tend to drop. But if inverse feedback is in use, any such reduction in output voltage causes a proportional reduction in feedback and a rise in over-all gain that raises the output voltage and partly neutralizes the tendency to drop. Similarly, if the load resistance is increased, or the load is removed altogether, the output

voltage tends to rise. The increased degeneration voltage fed back to the input acts to diminish the effective input signal, resulting in a limited rise in power level. A system in which the output voltage changes very little when the load resistance varies appreciably is one in which the internal resistance is low. The inverse feedback circuit tends to give this sort of characteristic.

Improved Output Regulation Reduces Distortion Caused by Varying Speaker Impedance

This improvement in output regulation serves to reduce another source of harmonic distortion and frequency distortion in a pentode or beam power output tube that feeds the voice coil of a loudspeaker. As was explained and illustrated in Lesson 19 in the November, 1943 issue of RADIO NEWS, the inductance of the voice coil causes its impedance to rise at the higher audio frequencies. Consequently, the impedance of a loudspeaker (including its output transformer) is not constant for all audio frequencies, and it presents a variable-impedance load to the output tube in whose plate circuit it is connected. Furthermore, one or more resonance peaks are usually present, at whose frequencies rather abrupt impedance increases occur. The variation of the impedance of the voice coil of a typical loudspeaker over the audio-frequency spectrum is illustrated in Fig. 2. The sharp rise at point A is caused by a resonance condition. The voice coil impedance varies between about 17 and 80 ohms. Naturally the output transformer will reflect this wide impedance variation into the plate circuit of the power tube. This wide variation of plate load will produce, if not corrected, considerable accentuation of the higher frequencies (and the frequencies around the resonance point) which is quite objectionable in the usual pentode amplifier. It may also cause harmonic distortion. Both forms of distortion may be corrected either by a simple corrective resistance-capacitance filter (see Part 19 of this Course) connected across the output transformer primary (with a corresponding loss of high audio-frequency power dissipated in the resistor), or by the use of inverse feedback. Any distortion due to resonance effects in the speaker will not be corrected by the filter. Inverse feedback must be employed to accomplish that.

Improved Output Regulation Reduces Necessity for Close Speaker Impedance Matching

One of the most troublesome problems in P-A installations is that of loudspeaker impedance matching. First, because the speaker voice coil is inductive, no speaker has a constant impedance at all frequencies. Therefore, the impedance reflected to the primary of the output transformer will also change, causing variations in the signal voltage developed across

(Continued on page 63)

WHAT'S NEW IN RADIO

RELAY FOR COIL CURRENTS

A new *Struthers-Dunn* Relay, Type 79XAX, is designed for a variety of electronic circuit applications calling for a highly sensitive unit having snap-action contacts. Contact pres-



sure of this relay remains constant despite slow variations in the coil current in which it is connected. Then, when the coil current reaches a certain point, the contacts operate with a positive snap action.

The relay operates on as little as 10 milliwatts in its coil circuit, and is recommended for dozens of highly sensitive vacuum tube applications, as well as in detecting overloads at low current levels. Its greatest field of usefulness lies in applications where current varies slowly between various limits, rather than quickly from 0 to rated value.

Details will gladly be supplied by *Struthers-Dunn, Inc.*, 1321 Arch St., Philadelphia, Pa. Please ask regarding Relay Type 79XAX.

COIL-WINDING CALCULATOR

Allied Radio Corporation, Chicago, announces the release of a new slide-rule type rapid calculator, permitting quick and accurate determination of inductance, capacitance, and frequency components of series or parallel tuned RF circuits as well as inductance, turns-per-inch, wire type, wire size, coil diameter and coil length for single layer-wound solenoid type RF coils. All values, in either case, are found with a single setting of the slide and are accurate to within approximately 1% for coils ranging from 1/2-inch to 5 1/2 inches in diameter and 1/4-inch to 10 inches in length. All

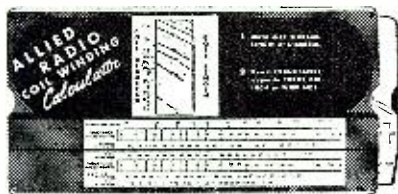

possible combinations within these limits are shown.

Wire types and sizes include 11 to 35-gauge plain enamel, 11 to 36-gauge

S.S.C., D.S.C., and S.C.C., and 12 to 36-gauge D.C.C. The rule is also engineered to indicate: turns-per-inch from 10 to 160; inductance from 0.1 to 15 microhenries; capacitance from 3 to 1,000 micromicrofarads; frequencies from 400 kilocycles to 150 megacycles with equivalent wavelengths in meters.

The speed and accuracy with which these factors can be related provide the engineer, maintenance man, service man, amateur, student, instructor, and experimenter with an invaluable tool. Priced at 25c each. Address correspondence to the *Allied Radio Corporation*, 833 West Jackson Boulevard, Chicago 7, Illinois.

CML PRODUCTION PLUGS

Developed for use with the Rotobridge in testing electronic equipment, *CML* production plugs are now available generally for use by electrical manufacturers. In their application to the Rotobridge, these plugs have had to be sturdy in construction in all respects, in order to withstand constant usage for many thousands of operations.

CML production plugs are 5 inches

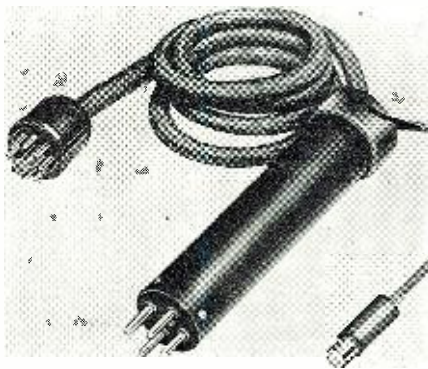

long and 1 1/4 inches in diameter, so that the handle will project above the average IF transformer, condenser, making it readily accessible. The Production Plugs are made with a heavy steel barrel and are filled with a wooden handle to permit ready removal from socket. All pins are case hardened steel to assure long life, yet may be replaced when worn or broken. In both the octal and loktal plugs, center key extends through in form of a threaded rod to permit cable to be fastened firmly in position without strain on pin connections. A flat head machine screw serves same purpose in the other plugs. In addition to the octal and loktal types, these plugs are available in 4, 5, 6 and 7 pin models.

Descriptive bulletin is available from *Communication Measurements Laboratory*, 116 Greenwich Street, N. Y.

INSULATION-RESISTANCE METER

A new electronic insulation-resistance meter for measuring the resistance of insulation in apparatus during the manufacturing process, thus re-



vealing imperfections before the product leaves the factory, has been announced by the Special Products Division of the *General Electric Company*. The instrument is also desirable for checking the condition of insulation of apparatus in service, and for use in the laboratory for rapidly testing a wide range of production or experimental samples of insulating material.

The instrument consists of a conventional electronic rectifier, a Thyrite bridge circuit, and an electronic-tube voltmeter. It is available in two types. One type has a scale calibrated from 1 to 50 megohms and measures resistance at 500 volts d.c., the other type has a 0 to 20,000 megohm total range and measures resistance over four different resistance intervals— from 0-5 megohms at 0-250 volts d.c. and 5-200, 50-2000 and 500-20,000 megohms at 500 volts d.c. Any range may be quickly selected by a panel-mounted rotary switch.

In the operation of the insulation-resistance meter, which can be used wherever 115-volt, 60-cycle current is available, the measuring leads from the instrument are connected to the apparatus or material to be tested. The scale-range selector switch is turned to the lowest range, and the power switch is turned on. If necessary, the selector switch is turned to successively higher ranges until the pointer of the illuminated scale is in the center portion of the scale. The resistance of the material under test is read directly in megohms. The test voltage is regulated to 500 volts d.c. by the Thyrite bridge, even though the 60-cycle line voltage is fluctuating.

(Continued on page 108)

THE SAGA OF THE VACUUM TUBE

By **GERALD F. J. TYNE**

Research Engineer, N. Y.

Part 10. Covering the evolution of the vacuum tube through the years 1914 to 1918, as a result of the research work done by Western Electric.

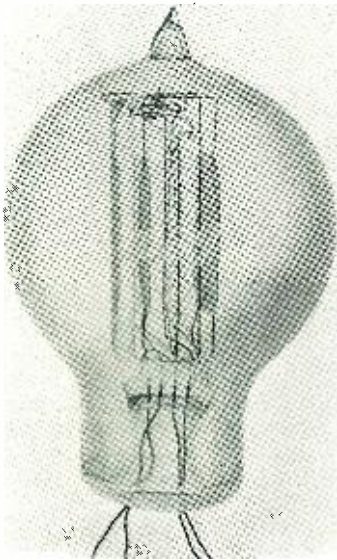

Fig. 92.

THUS far we have considered but one type of Western Electric tube. It has been treated in considerable detail, because of the evolutionary steps through which it passed. These steps show the results which may be attained through painstaking research and careful engineering with but one objective—to produce the most economical and reliable device to fulfill a given function, when operated under expert care and carefully controlled conditions.

Other tubes were evolved in the laboratories and manufacturing plants of the Western Electric Company during the period covered in the preceding articles. Some were for use in the telephone plant, some for the Armed Services of the U. S. Government, and others for divers applications which arose as time went on and wider vistas opened up.

Many of these went through developmental steps paralleling those of the

101 type and will be treated but briefly in what follows. One of the best known of these other tubes is the famous "V" tube. This was probably so called because it was intended for use as a "voltage" amplifier. It was first known as the type "VM"—V for *voltage* and M for *mounted*—but the "M" was soon dropped and it became known as the "V" tube.

The earliest vacuum-tube repeaters, as has been previously stated, used "L" tubes and were single-stage affairs. When the need for higher amplifications than could be obtained in these arrangements arose, two-stage repeaters were developed, and the "V" tube was used in the first stage to provide "voltage" amplification. Its plate-to-filament impedance was too high to permit it to be worked successfully as an output tube, however, and the second stage was an "L" tube with its lower output impedance.

The first experimental "V" tubes

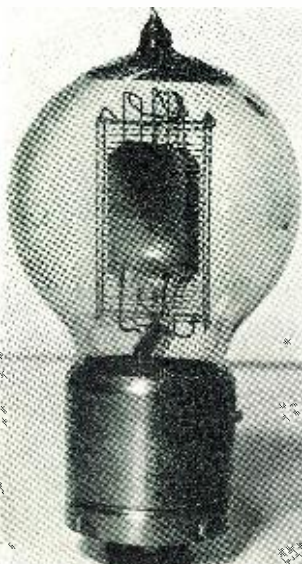

Fig. 93.

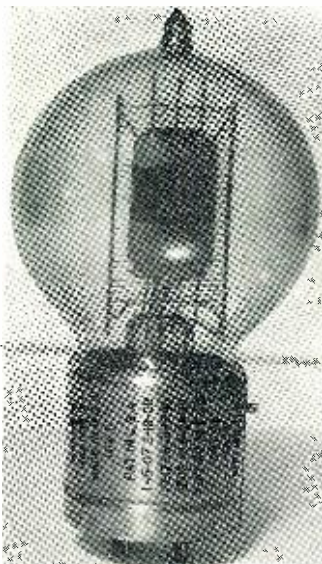

Fig. 94.

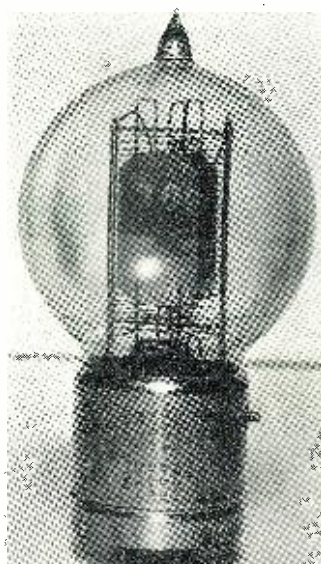

Fig. 95.

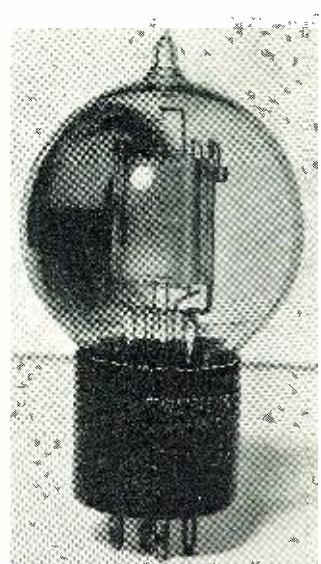

Fig. 96.

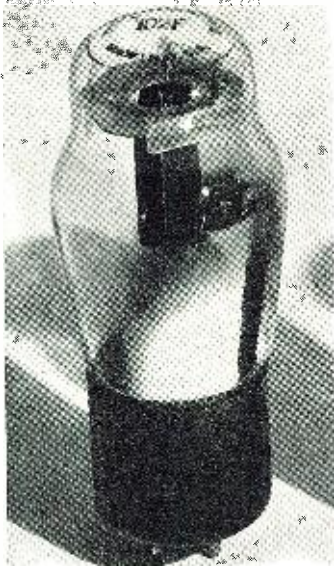

Fig. 97.

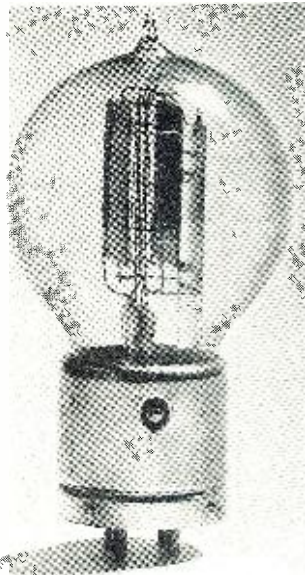

Fig. 98.



Fig. 99.



Fig. 100.

were made about the middle of 1914 and the first commercial product appeared early in 1915. Fig. 92 shows one of the earlier tubes before basing.

The "V" tube used the characteristic Western Electric "ladder type" grid and had 31 laterals on each side. The grids were considerably larger in area than the plates, and the filament was A shaped. The spacing between grids was about 1/8 inch and between plates about 1/2 inch. The base used was the same machined brass base used on the "L" tube which has been previously described.

Like the "L" tube, the first of the "V" tubes probably carried no patent markings. Beginning late in 1915 patent markings were applied in a manner similar to that of the "L" tube of that time. In 1916 the code designation "102A Telephone Repeater Element" was assigned to the "V" tube. This was later changed to that of "102A Repeater Bulb."

It is not our purpose to go into further detail concerning the progressive changes made in the "V" tube. However, for the benefit of tube collectors Fig. 93 shows one of the variants of the 102A.

Up to the end of 1918 all of the "V" tubes and some of the other tubes made by the Western Electric Company had been manufactured in the shops of the Engineering Department of the Company in New York. This was done because of the need for close engineering supervision in the early manufacture of a new device. By the end of 1918 progress was considered sufficient to permit their manufacture in the regular factory, and accordingly, production of some of them, among which was the 102A, was begun at the Hawthorne plant of the Company in Chicago.

All of the early Western Electric tubes had a serial number etched or sandblasted on the bulb. In order to distinguish between tubes made in New York and in Hawthorne the tele-

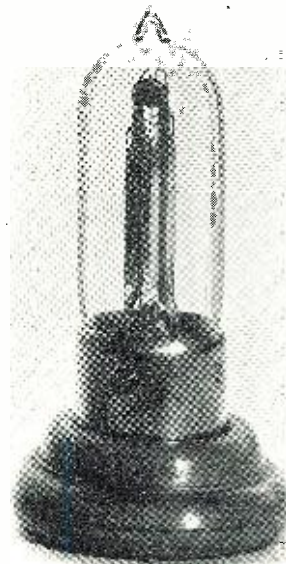

Fig. 101

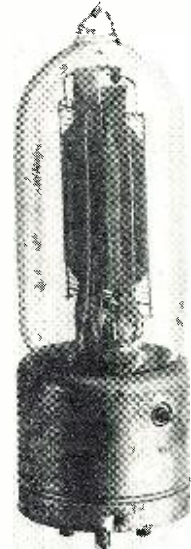

Fig. 102.



Fig. 103.

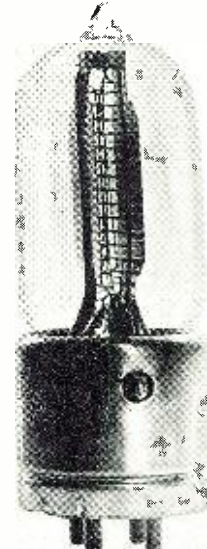

Fig. 104.

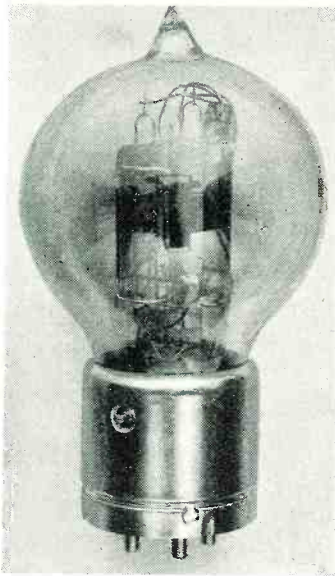

Fig. 105.

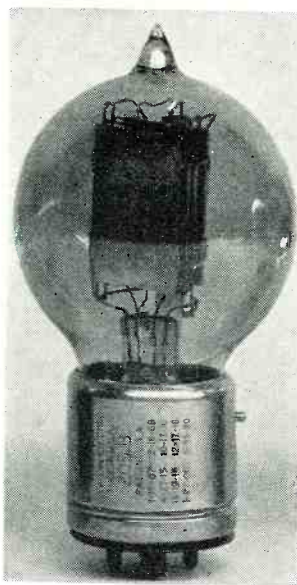

Fig. 106.

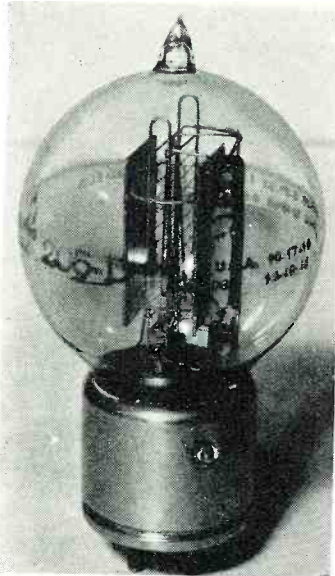

Fig. 107.

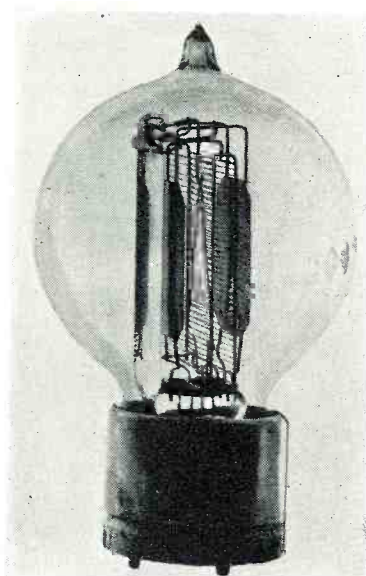

Fig. 108.

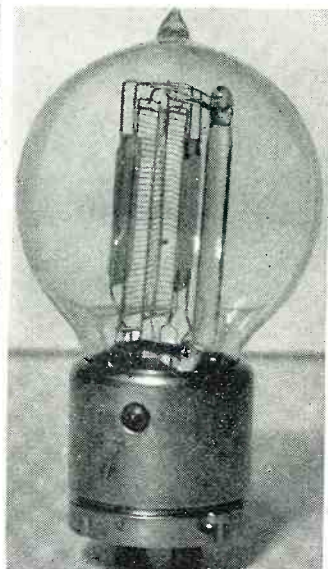

Fig. 109.



Fig. 110.

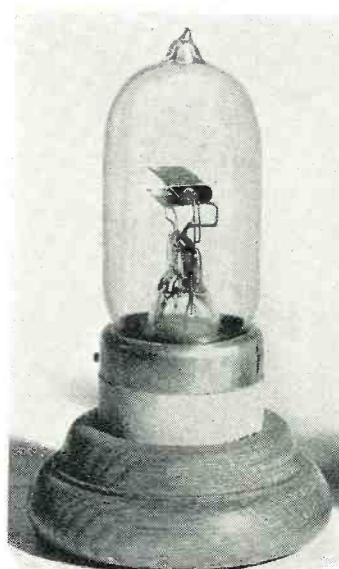

Fig. 111.

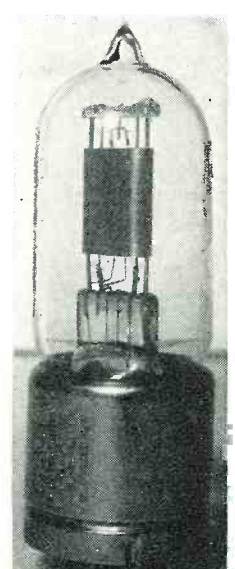

Fig. 112.

phone repeater type tubes made at Hawthorne had the letter "H" appended to the serial number. When production became great enough so that the number of digits in the serial number increased beyond five, the designation letter was changed to "A" and the numbering repeated. The tubes made at New York had no letter included in the serial designation.

There were also some minor details of construction in which tubes made at Hawthorne differed from those made at New York. One of these was in the positioning of the laterals of the grid. In the tubes made at New York the grid laterals were welded to the vertical support wires on the outside of the frame; that is, the side away from the filament. Tubes made at Hawthorne had the laterals on the side of the frame nearer the filament.

The construction of the 102A Repeater Bulb was similar to that of the 101B in that the elements were supported by a glass arbor welded to the edge of the press. Early in 1922 the 102A was replaced by the 102D which had an improved filament, operating at the same filament current as the 101D. The construction was soon changed so that the arbor was attached to the stem below the press, in a manner analogous to that of the later type 101B and the 101D. The single A filament was retained since the normal plate current of the 102 types was much lower than that of the 101 types and the electron emission from the smaller surface was adequate.

From this time on the changes in the 102 series, such as location and type of markings, substitution of molded for metal base shells, etc., in general followed those of the 101 series and will not be detailed here. Again for the benefit of the tube collector photographs of some of the variants

(Continued on page 90)

OHMITE RHEOSTATS and RESISTORS



Maximum Performance Under ALL Conditions

You can always expect the fullest measure of performance from Ohmite Rheostats and Resistors. *Because, they're made extra sturdy . . .*

to provide accurate resistance-control day after day under the most critical operating conditions.

This dependability has been time-proved in electronic and electrical equipment in all types of aircraft and in the tools of production. Ohmite Engineers are glad to assist you on any resistance problem.

Approved Types for Army and Navy Aircraft.

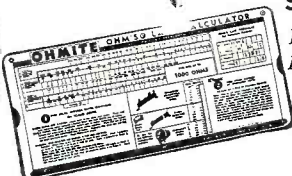

Send for Handy Ohm's Law Calculator

Helps you figure ohms, watts, volts, amperes—quickly. Solves any Ohm's Law problem with one setting of slide. Send only 10c in coin for handling, mailing

OHMITE MANUFACTURING COMPANY

4885 FLOURNOY STREET • CHICAGO 44, U.S.A.

Foremost Manufacturers of Rheostats — Resistors — Tap Switches

Two-Way Radio

(Continued from page 25)

functioning with frequency modulation in conjunction with other phenomena. In fact the Association of American Railroads and important member railroads have already investigated this plan and are receptive to proposals for postwar utilization with moving trains.

Generally speaking, the postwar 2-way radio set will have clarity incomparable with anything heretofore known. It will have a signal strength within the horizon which will be much greater than anything thus far achieved with mobile units. It will function for the full horizon and because of the many integrated advantages and efficiencies incorporated in its design, it will reach even into the adjacent horizon. Since the microwave band now feasible to utilize contains already 100 times more channel space in terms of kilocycles than that utilized by all existing radio stations in the world, and what is even more important . . . the fact that these frequencies can be used again every other horizon, means that postwar 2-way radio communication faces a very great future.

How great is this future? It is a future of 5,000,000 potential sets within the next 5 to 10 years. It is a future where 30,000 jobs will be created in connection with its manufacture, installation, maintenance and utilization. What are these new applications that will increase the market 100 times? Here are a few utilizations that experienced radio engineers claim will be provided.

1. 2-way communication between fixed and moving points on the railroads of the United States as well as between the trains themselves and for front-to-rear communication on the same train. One group is now quoting

a blanket rate of \$30 per mile of route to railroads for complete 2-way coverage.

2. Taxicab fleet dispatching for communication between dispatching point and taxicabs as well as between

taxicabs themselves. It will avoid the necessity of aimless cruising in congested city streets. A taxicab will discharge his passenger and wait at that point for another call. If someone desires a cab, a telephone call to

TABLE I

Advantages of postwar two-way FM radio sets over the prewar AM type.

1. *Very low power.* One system of great promise coming out for postwar railroads and taxicabs has an output power of 1/100th of a watt output. Likewise it has a very small power consumption.

2. *Functions on the microwave band using frequencies between 100 and 10,000 megacycles with emphasis above 2,000 megacycles.*

3. *Utilizes frequency modulation with a simplified and very remotely related offshoot of the Klystron Oscillator.*

4. *The transmitter component utilizes microphone, input transformer and a special oscillator of a dependable type. The receiver still will resemble the present day FM 2-way receiver but will use miniature tubes having higher amplification factors and lower interelectrode capacitances.*

5. *It will use a wave-guide antenna with radiation as desired.*

6. *The antenna will be focused in almost every case. It will be controllable as to width and elevation of the beam and it can be sent out in conic or rectangular fashion to occupy a limited sector. For railroads it will be directed down the track with gain as high as 2,000 if desired. Directivity is simplified since a half*

wave may represent only an inch in length on microwaves. This compares with 12 to 18 feet in the present ultra-high frequency police band which makes direction radiation difficult because of dimensions and physical considerations.

7. *Equipment will be compact, light weight and inconspicuous.*

8. *Reception will be clearer than anything heretofore available and the receiver will be quiet when no signal is coming through.*

9. *It will be much less costly than existing sets and will justify replacing existing equipment.*

10. *It will have hundreds of times more signal strength than any existing 2-way mobile set. Its gain can be integrated because of the following:*

Initial power 1/100th of a watt.

Advantage of 3 to 1 by use of FM over AM.

Deviation ratio of 100 to 1 utilizing more of receiver bandpass.

Receiver operates above noise further than AM. 10 to 1 or more.

Focused antenna possible with gain of 100 to 2,000 times. This integrates to $1/100 \times 3 \times 100 \times 10 \times (100 \text{ to } 2,000) = 3,000 \text{ to } 60,000$ watts as compared to present day AM types on the ultra-high frequency band used in police radio, using 10 or 15 watts.

Fig. 1. Contemplated two-way microwave telephone system for a typical city area. Provides communications between headquarters to mobile units, mobile units back to headquarters, mobile units to other mobile units, and headquarters to headquarters. Points with arrows are unattended 2500 megacycles automatic relay stations.

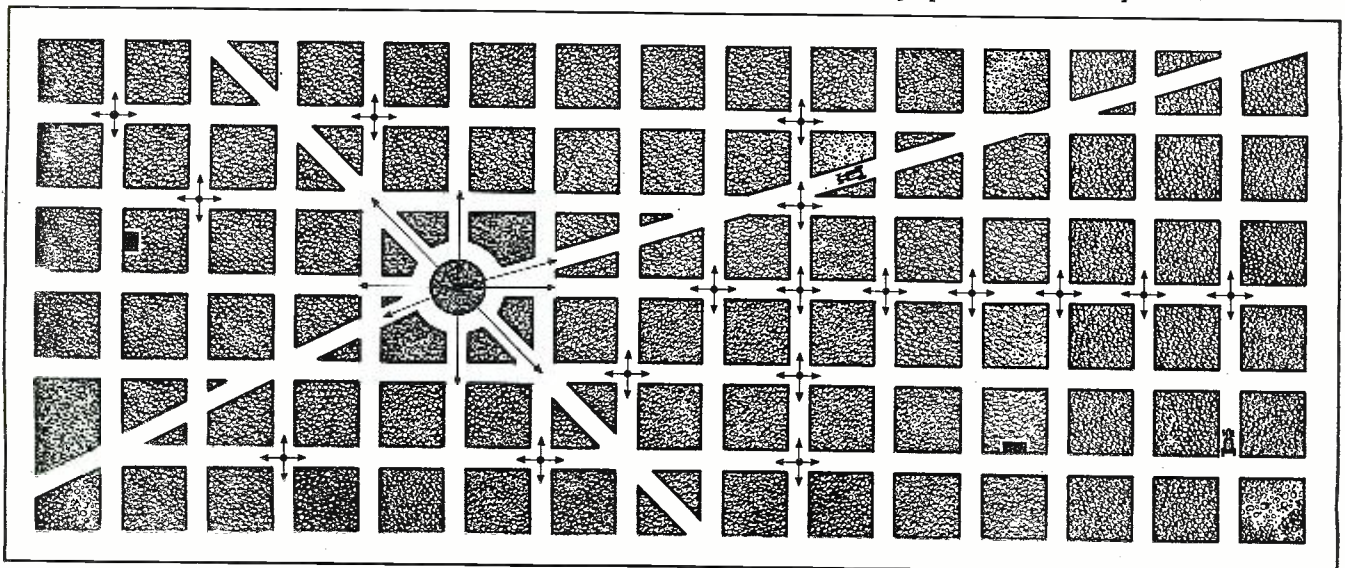

When building their own testing equipment . . .

Most delicately attuned of all equipment is that used by a manufacturer in testing his products. Many fine names insist upon DeJur precision instruments when building such equipment. For example, the oscilloscope used in the laboratories of the Electronic Corporation of America incorporates one of the various meters bearing the DeJur trademark.

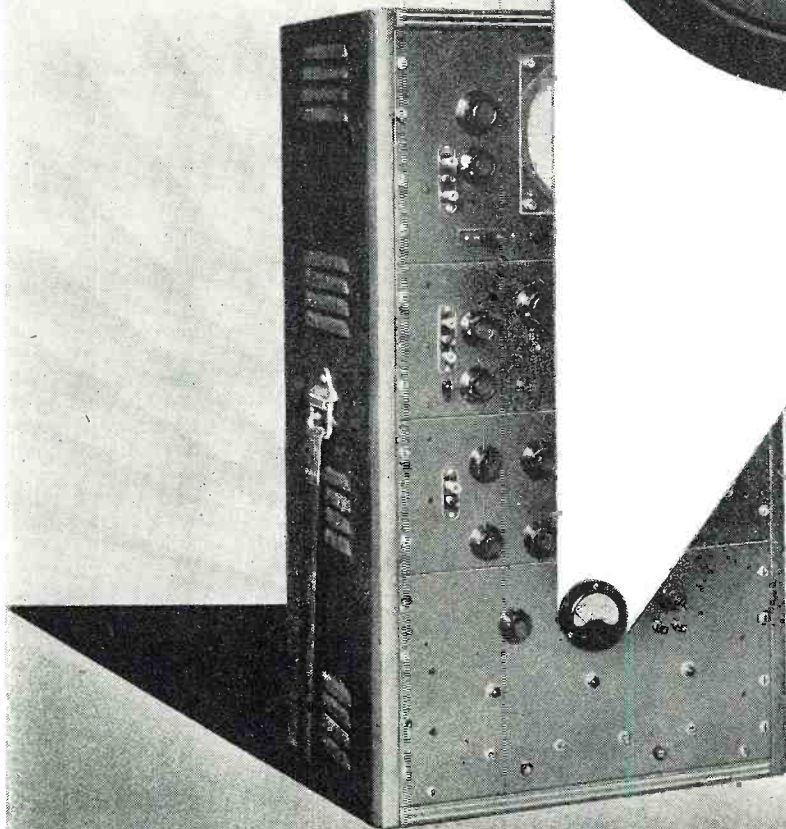
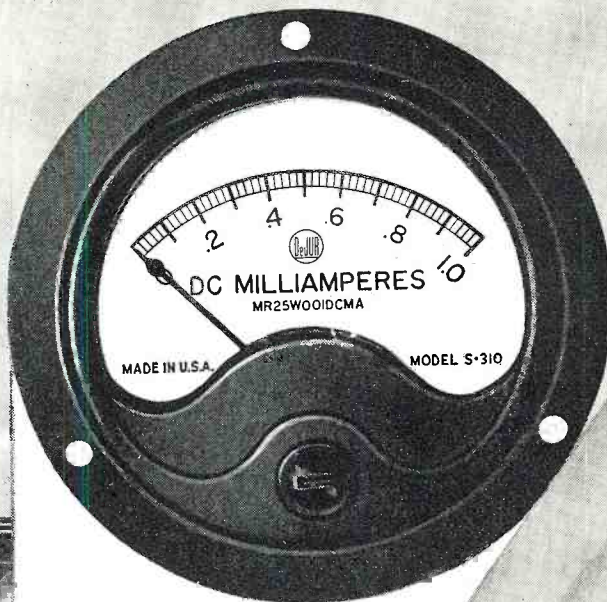

That DeJur instruments are "preferred stock" may be traced to DeJur accuracy, dependability and long life. Refinements in design and construction, growing out of 25 years of distinguished service in the electrical field, give our meters certain definite advantages which become immediately apparent upon application. A DeJur engineer will be glad to assist you . . . whether for your wartime or peacetime program.

The ECA oscilloscope in which a DeJur instrument is an integral component.



Help Shorten the War . . . Buy More War Bonds

DeJur-Amsco Corporation

MANUFACTURERS OF DEJUR METERS, RHEOSTATS, POTENTIOMETERS AND OTHER PRECISION ELECTRONIC COMPONENTS
SHELTON, CONNECTICUT

NEW YORK PLANT: 99 Hudson Street, New York 13, N. Y. • CANADIAN SALES OFFICE: 560 King Street West, Toronto

March, 1944

Fill 4 Impedance
Requirements with
ONE Turner U9-S

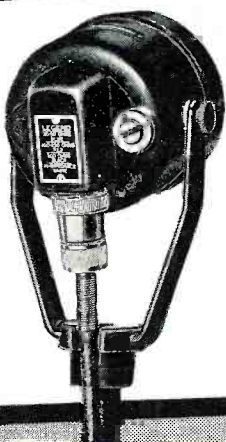

**U-9-S is Ready for Any Job —
without Duplicating Equipment**

Whether you need to work at 50 ohms on long lines — or want 200 to 500 ohms for that particular job — or find you must use balanced line connections because of noise or circuit conditions — or if you want to work standard high impedance on regular shorter lines, ONE Microphone, the TURNER U9-S, can fill all your needs. A twist of the switch shown at back of Model U9-S can give you your choice of impedances. Adjustable to semi or non-directional operation. Level —52DB at high impedance. Response is free from peaks and holes from 40 to 9,000 cycles. For sure-fire performance under any and all acoustic and climatic conditions, for rugged dependability without distortion, always specify Turner Microphones.

For complete information and prices on U9-S and other mikes pictured, Write TODAY.

FREE We've a copy of Turner's new Microphone Catalog for YOU. Write for yours NOW.

Crystals Licensed Under Patents
of the Brush Development Co.

The TURNER Company

Pioneers in the Communications Field

CEDAR RAPIDS, IOWA, U.S.A.

211 Dynamic



22X-D



9X-D



99-999



Dispatcher



MM

the dispatching office will dispatch the nearest cab in the customer's vicinity. Frequently the cab may be within a block of the call and furnish excellent service, arriving almost at the time the phone call is completed.

3. Trucks, buses, delivery vehicles and even passenger cars can be contacted or they in turn can communicate while in motion to change their route or report any occurrence.

One group has estimated that it can provide full coverage on every street and avenue on the island of Manhattan, New York City for a total of \$30,000 in the microwave band. It proposes to do it by providing an automatic relay station on every street and avenue in the city except at a rotary circle where one station can cover all streets and avenues radiating from there. Fig. 1 illustrates the kind of system they have in mind.

Amplitude modulation is definitely out postwar unless the application is so local and unimportant that any degree of efficiency, regardless how small, will suffice. This will be so because it is desired to obtain all the advantages of deviation ratios, frequency swing, receiver's inherent bandpass on very high frequencies, signal to noise ratio, freedom from interference and maximum receiver sensitivity.

The postwar set will be inconspicuous. It requires no tell-tale or vulnerable fishpole antenna to strike trees or obstructions. Its size will be so small as not to be recognized and it can fit in plenty of available spaces. Its battery consumption will be about one-fifth that used today by 2-way mobile radio equipment. The postwar set, because of cost, standardization and simplicity, will be such that present day radio systems will not find the cost prohibitive to change over and abandon the ultra-high frequency band. Neither will the cost prohibit using a large number of automatic relay stations to cover any required area and set of conditions. Users of such equipment will not require their own servicing personnel and service depots or parts. Tentative quotations are \$200 per station completely installed with perpetual maintenance and parts replacement for \$50 per year per station. Equipment will be removable or replaceable with old units replaced by overhauled units in a matter of minutes and returned to manufacturer's service depot for overhaul under contract.

Table I indicates how the postwar 2-way radio set, while having an actual power of 1/100th to 1/10th of a watt, will be as efficient as an AM set of 10,000 watts based on prewar standards.

In a forthcoming issue of this magazine, the writer will present an article on "Ultra-High Frequencies versus Microwaves." In connection with this article, readers are also referred to page 42 of December, 1943 RADIO NEWS entitled "Am vs. FM in Two-Way Radio."

Who Said The "Ham" Is Finished?

THERE have been rumors to the effect that the radio Amateurs were going to be denied their old frequency bands, and given new bands of such high frequency as to be useless for medium and long distance communication.

Some rumors say "Remember the last War? We are going to get the same treatment this time!"

Now, we don't believe the "Hams" should be denied their rightful place on the air in bands suitable for communication beyond the horizon—and further, we do not believe that our Government would want to see those privileges denied.

Are not the "Hams" fighting on many battlefronts, working in war factories and laboratories for a New World wherein the individual will be able to live and enjoy his hobbies, his church and other personal freedoms which go to make up a healthy, happy world?

It is well-known among Government officials whose task it was to build our great war-time communications system that from the rank and file of amateurs came executives, instructors and thousands of engineers and operators. Without this nucleus of experienced men, it would no doubt have taken a much longer time to reach the present high degree of perfection in the communications branch of our fighting forces.

In every emergency Amateurs have proved their ability and willingness to come to the aid of their Country—who would be so unjust as to want to deny them their small place in the radio spectrum? We do not believe these rumors that the "Ham" will be denied his privileges, we believe rather that those who speak so much of justice coming out of this war will see to it that the Amateur receives his just reward.

The entire radio industry knows well, and appreciates the many contributions "Hams" have made for the advancement of high frequency radio communications, and surely they too can be counted on to assist the "Ham" in regaining his privileges *when the right time comes.*

HAMMARLUND MANUFACTURING CO., Inc.

460 West 34th Street, New York 1, N. Y.

Theory of U.H.F.

(Continued from page 43)

of the same electron giving up energy, causing oscillation.

Returning now to the mechanism of the tube it can be seen that all electrons leaving the cathode when the plate voltage is increasing will absorb energy and probably be captured by the plate, whereas those electrons that are emitted by the cathode when the plate voltage is decreasing will not reach the plate, but rather oscillate in the manner previously described. Since the same number of electrons are emitted when the alternating plate voltage is going positive as when it is going in the opposite direction, and since the energy-absorbing electrons are removed as soon as they strike the plate while the energy-losing electrons oscillate for several cycles, the source of alternating voltage gains energy. This condition is precisely the same as in the positive grid or Barkhausen-Kurz generator.

At first thought, it might be desired that the energy-losing electrons be kept in the interelectrode space as long as possible. However, it has been found that this is not so. The reason is due to the changing phase relation of the induced voltage. With each successive cycle of oscillation, the electron has less and less energy available and so the distance through which it moves decreases and the transit time goes down. This is equivalent to an advance in phase of the electron oscillation relative to the alternating plate voltage. If this shift continues, not only will less and less energy be given up by the electron, but it may even start absorbing energy. It has been found that the magnetic field must be slightly tilted (not more than a few degrees) with respect to the tube axis

Fig. 8. (a) Structure of end plate magnetron. (b) Method of applying magnetic field.

Courtesy of D. Van Nostrand Co., Inc.

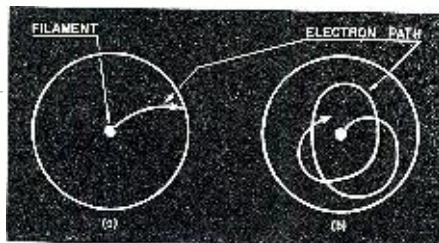
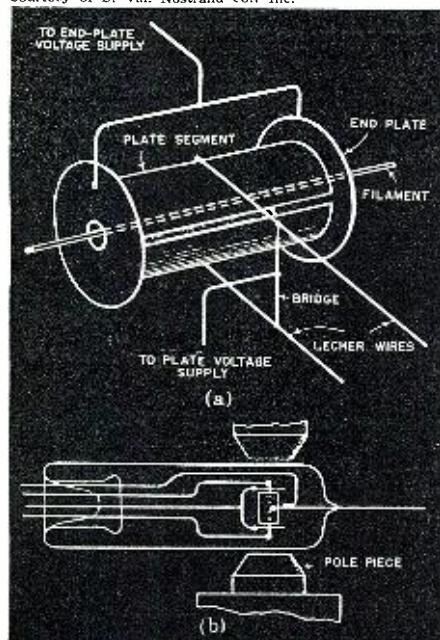

Fig. 7. (a) Electron absorbing energy from alternating power source. (b) Electron giving up energy causing oscillation.

in order to obtain best results. This tilting action imparts a velocity to the electrons parallel to the filament and after several cycles in the interelectrode space the electrons strike the plate and are removed. The angle is quite critical and must be changed with plate voltage. The problem, of course, is obvious. The electrons should be allowed to remain in the interelectrode space until all the energy that can be absorbed has been absorbed, then they should be quickly removed. This explains the tilting action. One bad result of this tilting is the heating of the glass envelope of the tube itself. If allowed to continue for any length of time, the glass will melt with the eventual destruction of the seal.

Linder has advanced a solution of the tilting process that is used most widely in all the magnetrons. He found that by putting in end plates, shown in Fig. 8, and applying a small positive voltage to them, that the tube no longer has to be tilted for the electrons to be removed. It has also been found that the efficiency has increased due to these end plates.

The theory of the mechanism of transit-time magnetrons holds essentially whether the anode is a one-piece cylindrical plate, a two-segment plate or even a four-segment plate. It is true that there are slight differences in the electron motion in these various types of magnetrons, but these need not concern us here since, as mentioned, the explanation is essentially the same.

For optimum output the transit-time magnetron requires a smaller filament emission than the negative-resistance tube and is far more critical to changes in this emission. This is probably due to the effect these changes have on the space charge in the tube itself. It is customary to interpose a filament-current stabilizer between the source of power and the filament. Another source of trouble is in keeping the magnetic field strength constant, since the formula previously given for wavelength is directly connected to this factor. The difficulty is avoided by using electromagnets at high voltage and low current. The schematic diagram for a power supply given in the chapter on the Klystron tube can also be used here.

The useful frequency range of any one magnetron tube is approximately 2 to 1. In order to cover a wide range of frequencies many tubes of varying sizes must be used. It was found that

the optimum anode diameter should be $1/20$ the wavelength desired. Of interest to engineers and circuit designers is the fact that the transit-time magnetron can be operated with a much lower load impedance than the negative-resistance magnetron and so can be operated with tuning elements of a lower Q. One explanation of this observation states that it is due to the fact that a small amount of potential on the plate segments can cause large circulating currents which in the ordinary tube would require a much greater voltage. Oscillations have been known to exist in tuning circuits with an impedance as low as 100 ohms, which is very helpful in attaining the high frequencies.

In looking up the literature on the magnetron tube, one will often find the statement that a smaller magnetic field is needed in the transit-time tube than in the negative-resistance version. That this is true can be seen from the following line of reasoning. For the negative-resistance type magnetron the efficiency begins to fall off when the transit time of the electrons is greater than about $1/10$ of the period of oscillation. The magnetic field must therefore be correspondingly greater in order for the electron to complete the cycle that much sooner. In the transit-time oscillator, the allowable electron transit time is $1/2$ of the oscillation period. Hence, not so great a magnetic field of force is required, the difference being in the ratio of about five to one. This result is a considerable saving since the difficulty in constructing a suitable electro-magnet rises rapidly as the number of uniform flux lines required increases.

The subject of modulation of the magnetron has not been freely settled to the satisfaction of all concerned. It might be stated that the method probably adopted will tend more toward frequency modulation than amplitude modulation.

One more mention should be made of the effect known as "filament bombardment" before closing the chapter on magnetrons. This effect has been noted by many experimenters and contributes much toward the limiting of the usefulness of this type of oscillator. When attempts are made to obtain large amounts of power, it is found that the filament of the tube begins to heat up and eventually disintegrate. The reason has been attributed to the bombardment of the filament by electrons or ions containing considerable amounts of excess energy. One means used to overcome this lies in shielding the filament to some extent while another method proposed is to attempt a filament-stabilization method. As stated, this defect shows up when the power requirements are raised, but it is believed that the newer type of magnetrons have already eliminated this difficulty.

In summarizing the contents of this chapter it should be pointed out that in the negative-resistance magnetron

SPRAGUE TRADING POST



A FREE Buy-Exchange-Sell Service for Radio Men

WANTED IMMEDIATELY—3 dynamic mikes with stands and cables (Amer. D4T, D8T, D9T, VR2T; Turner 99, U9S; Amperite PG, etc.); 2 induction phono-motors and one 3 in. or 4 in. sq. 0-1 ma. meter. Cash. David Williams, P.O. Box 281, Pleasanton, Calif.

WANTED—Good comb. tube tester & set analyzer such as Triplett No. 1183. Name price. Philip P. Goldstein, 288 Ave. P., Brooklyn 4, N. Y.

WANTED—Pocket AC-DC V-O-M. Describe fully for quick reply. H. C. Dexter, Box 262, Princeton, N. J.

WANTED—Tube tester, also sig. generator. Describe fully. Philip Kirkpatrick, Greenwood Mt., Maine.

FOR SALE—Two type 78 tubes with shields, 55c ea.; No. 41 at 47c; 6A7 at 56c; 6B7 at 70c. Want used radios & parts. C. Brown, 502 N. High, El Dorado, Kans.

TRANSFORMERS FOR SALE—All new, in original boxes. Wide variety of hard-to-get types, etc. Write for complete list and prices. Kluge Radio Co., 1913 Montrose St., Los Angeles 26, Calif.

FOR SALE—12-Watt amplifier—P.P. 2A3, output transformer 8016 ohms, heavy-duty trans. and chokes, compl. with tubes, \$30. Frank W. Jones, Gabbs, Nevada.

EQUIPMENT WANTED—Tube testers: Jackson No. 636; Supreme 589-P; Triplett 1612. Signal generators: Jackson 640; Supreme 571; Precision E-200. V-O-M's: Jackson 642; Hickok 202; RCA Jr. Voltohmyst; RCP 662. Also Jackson 650A condenser tester; C-D BF-50 and C-D BN capacitor bridges, also panel mounting meters, all ranges. Chas. P. Courtney, 520 E. "C" St., Belleville, Ill.

WANTED—Triplett V-O-M or Weston. Also a good sig. generator. Wm. A. Fremlin, R.F.D. No. 1, Milford, Mich.

FOR SALE OR TRADE—Supreme No. 589 combined RF and audio signal generator, \$55. Will buy for cash complete Rider's manuals, chanalyst, signalyst, volt-ohmyst, capacitor analyzer, Hallicrafter Sky Traveler. Henry Balabanow, 3814 N. Sheffield Ave., Chicago 13, Ill.

WANTED—Good used test eqpt. of late design for new shop. William W. Ulery, 301 E. Martin St., San Antonio, Texas.

WANTED—Sig. generator and vac. tube volt meter. Cash. R. L. White, 1748 Third Ave., Oakland 6, Calif.

URGENTLY NEEDED—Com. receiver or any portable commercial radio and test eqpt. Pvt. Lloyd C. Wood-

ard, 534th Service Squadron, Kelly Field, Texas.

FOR SALE—Have goodly number of 1C5GT/C; 6L7G; 6L7; and 78 tubes to sell or trade at sacrifice for more popular tubes. C. K. Allen, 1700—7th Ave., Beaver Falls, Pa.

EQUIPMENT WANTED—Hickok No. 530 tube checker; Hickok No. 177 or 188 sig. generator; Solar CB 1-60 or Jackson 650 A capacitor analyzer. Ferd. Nessler, 1020 University Ave., Dubuque, Iowa.

WANTED—Super Skyridder SX-32. Good cash price. John Gil, 160—8th St., Passaic, N. J.

V-O-M WANTED—or V-O. Either factory-built or compl. factory assembled kit for either. Tech. Sgt. C. L. Hollman, Darnall General Hospital, Danville, Ky.

FOR SALE—No. M1534 power transformer 1200 V. C. T. at 200 ma. 6.3V at 3A and 5V at 3A. Shure 5DB carbon mike; also one large and one med. size DB mike transformers 200 C.T. to single grid. Want 12" heavy duty PM speaker. Maxeiner's Radio Service, Okawville, Ill.

WANTED—First model Meissner 12-tube F.M. receiver with or without 6L6 audio stage. D. Hill, 45 7th Ave., New York 11, N. Y.

FOR SALE—Meissner 9-1000 push button remote control unit, \$15. Also battery and electric type used radios; 1200 tubes (all types)—satisfaction guaranteed or money refunded; two master units wireless intercom system, \$50. Will trade Colt 32 cal. automatic for radio tubes. Goodwin Radio Shop, Rankin, Ill.

WANTED—RCA signalyst or other sig. generator of good make, also RCA-Rider Sr. voltohmyst in good condition. Walter Schofield, 346 Oak Grove Ave., Fall River, Mass.

FOR SALE—New Astatic JT-30 xtal mike with cable, \$10. Want one

807, RK39 or similar tube for cash. Bob Stefan, 332 Herrick Ave., Teaneck, N. J.

WANTED—RCA camera type receiving set. Describe fully. Wallace Wolfe, R. R. No. 3, Warsaw, Ind.

FOR SALE—Westinghouse O-15 DC Ma.; Weston O-5 DC voltmeter; Weston AC-DC O-6 amps.; Sterling O-15 DC Ma.; G-E O-8 DC amps.; Sterling O-3 AC voltmeter; 83 mercury rectifier; two 4 mfd. 1000 V. new condensers; Brandes headphones; 8" fan; AC noise filter; electric clock; Triplett 3332 battery oscillator. \$25 takes all. S. J. Zuchora, 2748 Meade St., Detroit 12, Mich.

WANTED—Recording unit with play-back less amplifier, speaker, mike, etc. M. L. Birkett, 2415 E. 7th St., Tulsa, Okla.

FOR SALE—RCA 811, \$3.50; 845, \$10; Westinghouse 805, \$13.50; Eimac 150TS, \$25; Eimac 100TS, \$13.50; DeForest 511, \$10; RCA 204A, \$35. All new. Used Sylvania 211C, \$5; RCA 809's, \$2.25; RCA 76 (isolantite base), 75c. Also Hoyt O-1 ma. movement 3½" meter with VOM scale mounted in Bud meter holder, \$5; Hammarlund Comet Pro receiver rebuilt with metal tubes, compl. \$35; RCA Jr. velocity mike, cradle mtd., No. 4035, \$44; Astatic D104 crystal mike, \$22.50, also various speakers. Write for list. Fred Craven, 2216 So. 7th St., Philadelphia 48, Pa.

WANTED—4 or 5-band coil assembly, also S. W. signal booster and 15" speaker to handle 20 to 25 watts, electro dynamic. Henry Ecklund, 290 E. Lawson St., St. Paul, Minn.

WANTED—Dual speed Green Flyer 110V. phono motor; Thordarson T15S91 output trans.; and T15C54 or T15C55 Thord. choke. Pfc. Thomas Slack, 33340576, Hq. & Plot. Co., 576 S.A.W. Bn., Drew Field, Tampa, Fla.

TUBES FOR SALE—5—024; 1A4P; 5—1A5GT; 1A6; 1B5 and other battery types. Write for list. Gerhard's Radio, Defense Highway, Lanham, Md.

WANTED—Rider's manuals 7 to 12. Also want to have R.C.P. multi-tester meter repaired. Oliver L. Bessetti, 18 South St., Danielson, Conn.

WANTED—Superior or RCP tube tester with charts. H. R. Ringold, 132 N. Doheny Dr., Beverly Hills, Calif.

WANTED—RCA voltohmyst Jr. Gilbert Bers, 1352 Sheridan St., N. W., Washington, D. C.

FOR SALE—200 assorted radio tubes, no high or low volt or rectifier types available. Also some repair parts. Write for list. J. C. Thimijan, 715 N. 7th St., Lake City, Minn.

FOR SALE—Hallicrafters S20R com. radio, like new. Tunes 550 kc. to 44 mc. \$50 cash F.O.B. Lewis C. Chapman, Rt. 1, Columbus, Miss.

WILL TRADE—printing eqpt. for radio test eqpt. Write for details. Roy B. Wanders, 3228 N. Osanam Ave., Chicago 34, Ill.

WANTED—Tube tester in good condition. R. M. Blomquist, Maplewood Station, Sulphur, La.

FOR SALE—Skybuddy receiver and two 552 Mallory vibrapacks, and one 551 vibrapack. Elmer E. Ash, 109 E. Woodruff, Port Washington, Wis.

WANTED—New or used RCA Jr voltohmyst; also O-200 micro-ampere and O-1 milliamperemeters. Robert Hamilton, 5029 Penn St., Philadelphia 24, Pa.

WANTED—Late model portable tube tester. Gabe's Radio, 113 E. Walnut St., Green Bay, Wis.

WANTED—Cash for Triplett 1200A V-O-M or other good make. I. C. Gutierre, 1019 N. Stanton St., El Paso, Texas.

SPRAGUE KOOLOHM RESISTORS AT WAR!

If you haven't been hearing much about Sprague Koolohm Resistors lately, it's only because there hasn't been much to say from a civilian standpoint. But there's been plenty happening nevertheless—and all of it has been bad news for the enemy. One after another, Koolohm construction with its famous insulation of heat-

proof, moisture-proof flexible ceramic has resulted in higher performance standards for various resistor types—from hermetically sealed precision meter multipliers, to bobbin-type resistors, and special heavy-duty wire-wound types. You'll be pleasantly surprised at the amazing advantages Sprague Koolohms will offer you A.V.D. (after V-Day)!

YOUR AD RUN FREE

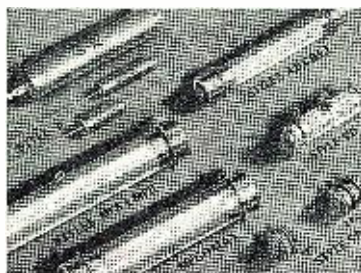

Send us your Sprague Trading Post advertisement today. We'll be glad to run it free as a part of our special wartime advertising service to the radio profession. "Equipment for Sale" and "Wanted" advertisements of an emergency nature will receive first attention. Different Trading Post ads appear regularly in *Radio Retailing*.

Today, *Radio Service-Dealer*, *Service*, *Radio News*, and *Radio-Craft*. Please do not specify any particular magazine for your ad. We'll run it in the first available issue that is going to press. Sprague, of course, reserves the right to reject ads which, in our opinion, do not fit in with the spirit of this service.

Dept. RN-34, SPRAGUE PRODUCTS CO., North Adams, Mass.



SPRAGUE CONDENSERS KOOLOHM RESISTORS

Obviously, Sprague cannot assume any responsibility, or guarantee goods, services, etc., which might be exchanged through the above advertisements



all i want is sym-pa-thy

by don herold

I'm a typical, everyday, bothersome customer of your radio shop. We have 3 radios at our house, and sometimes one of them goes haywire—although they usually work wonderfully—considering the beating we give 'em.

I know there's a war on, and I know you radio fellers have a heck of a time getting parts and help. I know you're on a spot. So I don't expect you to fix my radio as fast or as good as you usta. But—this war is on my nerves, too. I'm thinner-skinned than usual! I'm sensitive! I'm tender! So please be a little kind to me, mister. Please explain a little why you can't do this or that—and I'll stand for most anything!

"He said it would be 4 weeks before he could repair our radio—but he was so nice about it that I don't mind."



I quit one radio man because he barked at me and kept putting off my repair job and didn't tell me why. I've gone over to another radio feller who isn't any faster than the first one, but who takes the trouble

to always rub my fur the right way. This is the shop that's going to get my repair business after the war, and I'm hoping to buy a new FM set and a television outfit and a lot of electronic gadgets some day—and this shop'll be tops with me for all that business . . . and maintenance on it.



"They use International Resistors. Must be a good repair shop"

Incidentally, I like to know you are using famous parts in my jobs—such as International Resistance Units—whenever you can get 'em.

No. 1 in a series of special messages prepared by America's famous business writer, humorist and cartoonist, Don Herold. . . In sponsoring these Don Herold "broadcasts," IRC pays tribute to the thousands of Radio Service Men who, whenever possible, specify and use IRC resistance units in their work.



INTERNATIONAL RESISTANCE CO.

401 N. Broad St. • Philadelphia 8. Pa.

IRC makes more types of resistance units, in more shapes, for more applications than any other manufacturer in the world.



oscillator, the action comes from the negative slope of the static-characteristic curve which gives rise to the necessary negative resistance. Once the electrons leave the filament they travel on to one of the split-anode segments and do not oscillate in the inter-electrode space. Oscillations do not come from the travel time of the electrons, but rather from the fact that the electrons have a tendency to hit the plate of lower potential, a condition brought about by the strong magnetic field present.

In the transit-time magnetron, on the other hand, the oscillations are dependent on the time of flight of the electron from the filament to the plate and back again. Here the electrons that are most important remain in the inter-electrode space for a relatively long time, oscillating between the filament and plate. The path is usually complicated and any diagrams are, at best, only approximations. Fig. 7 is such a diagram. It is hard to say where the magnetron oscillator ends with the negative-resistance operating principle and switches over to the transit-time idea. The transition is not entirely distinct and the only generalization that can be made is to say that for very high frequencies, the transit-time oscillator should be used whereas for longer wavelengths, the negative-resistance magnetron is more efficient. The circuits remain the same in either case, the only change occurring in the operating conditions.

(To be continued)

Postwar Television

(Continued from page 46)

and the price of wheat in Russia today's news—let alone its heroic victories—so will television make the world's events visible to us—almost as soon as they happen. The education of our children, the dissemination of information of the new and proper methods of the raising and treatment of crops and livestock will be "televized" to all. Breeding methods, prices and discussion of agricultural problems will be broadcast—sound and sight—to all.

This unpleasant business of war has undoubtedly hastened television's debut. On the credit side of the last war are but few items; such progress would have been made with less loss of life and suffering, with great financial saving and better coordination under the civilizing influence of peace—but, nevertheless, it is true that the war hastened the general introduction of the airplane, tractor transportation, certain dye formulas and other inventions. It is not a civilized desire to hope for the war to hasten inventions (except for barbarous war profiteers) but, it still is a sad fact that the war does quicken the introduction of inventions; and military leaders realize the potentialities of television.

Photographers in planes may take pictures which may be almost imme-

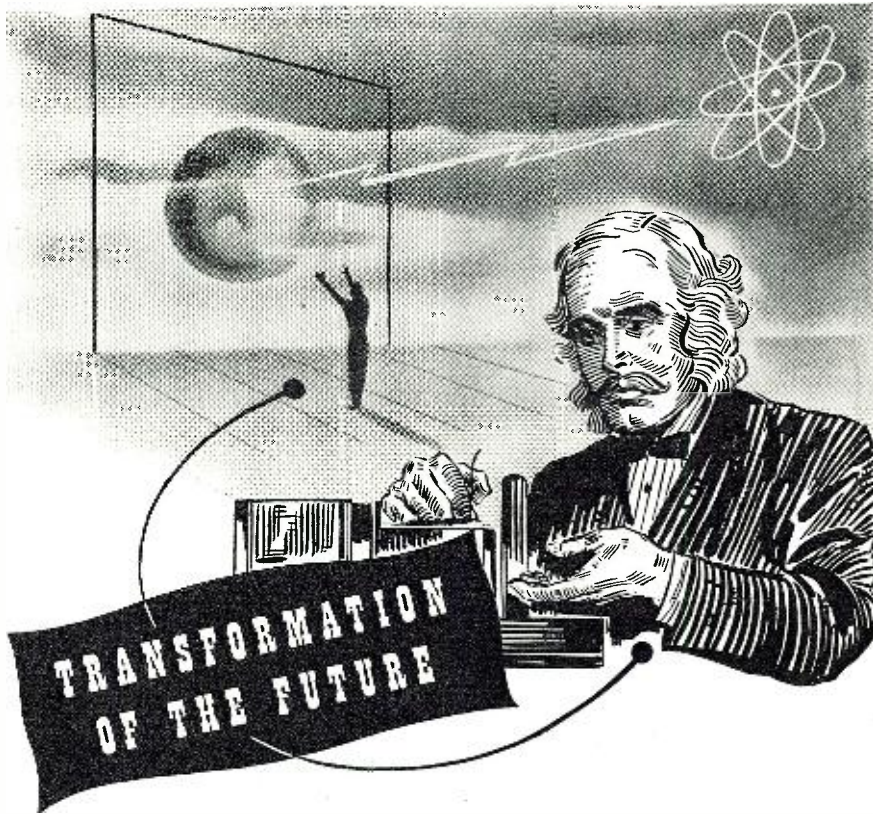

WHEN Faraday fiddled with bits of wire a century ago, he dreamed of a new electrical age. A skeptical politician asked him what good his electricity would produce and the scientist answered tartly, "Some day you will be able to tax it."

After the war the twentieth century results of electrical science, shaped and tested by military needs, will transform the world. And at the core of this technical revolution will be the coordinator of electronic energy—the transformer. In the most literal sense, Stancor engineers are planning now to contribute fundamentally to the transformation of the future.

SPECIFY



STANCOR

★ Transformers ★

STANDARD TRANSFORMER CORPORATION
1500 NORTH HALSTED STREET - CHICAGO

Manufacturers of quality transformers, reactors, rectifiers, power packs and allied products for the electronic industries.

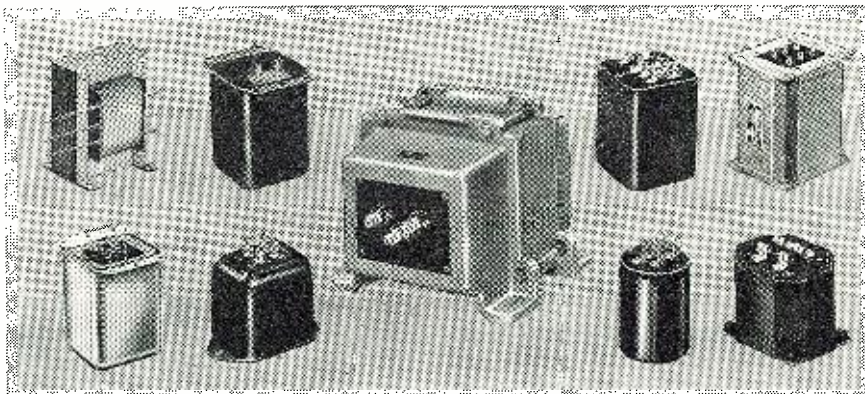

9 out of 10
BUSY RADIO
TECHNICIANS SAID

**"HERE'S THE WAY
 TO LEARN
 RADIO RIGHT!"**

GHIRARDI
TEACHES IT TO YOU
EASIER • BETTER • FASTER

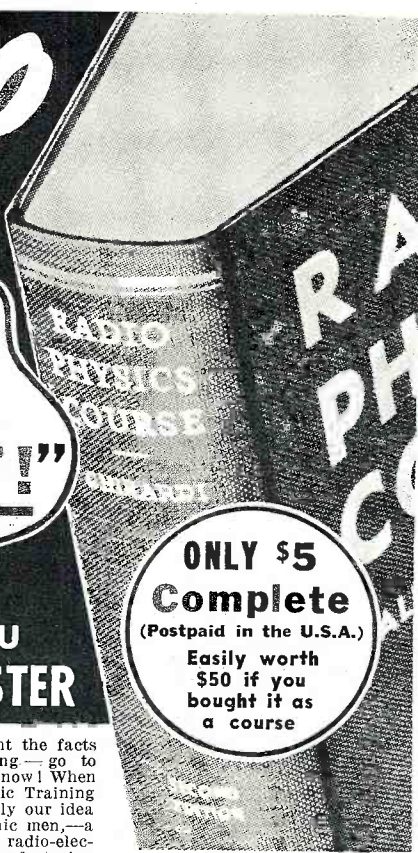

ONLY \$5
Complete
 (Postpaid in the U.S.A.)
 Easily worth
\$50 if you
 bought it as
 a course

724 OUT OF 817! When you want the facts about something—go to the men who know! When you want to find out what is the best Radio-Electronic Training for YOU—ask Radio-Electronic men! That was exactly our idea when we went to a mixed group of 817 radio-electronic men—a group made up of instructors, students, repair men, radio-electronic experts in the armed forces and in big manufacturing plants. We asked them to tell us exactly what they think of various books and courses now being offered for the study of Radio-Electronic fundamentals. NINE OUT OF TEN of these men wrote back that Alfred A. Ghirardi's RADIO PHYSICS COURSE book is their choice as the best buy on the market—far better than any other book or course they have ever seen. And, as they explained—

HERE ARE THEIR REASONS WHY:

- 1 "It's simple, clear way of thoroughly explaining every detail makes it the most easily understood of all Radio-Electronic books and courses.
- 2 "It teaches Radio-Electronic fundamentals more quickly and more interestingly than any other.
- 3 "It gives the most complete coverage of Radio and Electronic subjects—all in one handy volume.
- 4 "It is the most inexpensive, complete basic training available—easily worth from \$50 to \$100 if you bought it as a course."

TRAIN AT HOME—In Spare Time

Ghirardi's RADIO PHYSICS COURSE is tried and tested. It gives MAXIMUM training in MINIMUM time and at an absolute MINIMUM cost. You learn at home in spare time. You progress as fast as you want to. Actually Ghirardi's RADIO PHYSICS COURSE gives you the scope of 36 different courses in one—all packed into an easy-to-follow 972-page book with 508 clear illustrations, and 856 self-testing review questions. You can understand every word of it without previous training—and you'll be pleasantly surprised how easily you'll master the subjects that other books and courses make seem very complicated. Our 5-day Money Back Guarantee enables you to examine this great book for five full days—and get every cent of your money back if you're not more than satisfied.



Let A. A. Ghirardi—Radio's most widely-read technical author—help you start your training for a fascinating, profitable, wartime or peacetime job in the vast new Radio-Electronics field.

MAIL THIS COUPON NOW!

RADIO & TECHNICAL DIVISION
Murray Hill Books, Inc.
 Dept. RN34, 232 Madison Ave., New York 16, N. Y.

Rush me a copy of your big, 972-page RADIO PHYSICS COURSE BOOK. I am enclosing \$5. (\$5.50 foreign.)

Send C.O.D. (in U.S.A. only) for \$5 plus postage.

In either case, I may return the book within 5 days for refund if I am not completely satisfied with it.

Name

Address

City (and Dist. No.) State

NO OTHER COURSE LIKE IT

There is no substitute for Ghirardi's RADIO PHYSICS COURSE—simply because there isn't any other book or course like it at any price. That's FACT—not fiction—and backed up by PROOF, not mere claims!

M. J. Turim of Brooklyn, N. Y., says: "I've read many Radio books but have failed to find a more detailed, thorough, and easy-to-understand book than Ghirardi's Radio Physics Course. It's the best course on the subject available today—ABSOLUTELY UNBEATABLE."

J. R. Robertson, Jr., of Bessemer, Ala., says: "As simplified, complete and understandable a Radio-Electronic Training Course as I have ever seen AT ANY PRICE."

ELECTRONICS, TOO!

And don't forget, RADIO PHYSICS COURSE does not end at teaching you only Radio! The basic instruction you get from this big book is your introduction to the vast, rapidly growing field of Electronics, too. It is your "Open Sesame!" to more money and a better job in this amazing new industry you've been reading so much about.

Order your copy today. SEE it. EXAMINE it for yourself. Here is our GUARANTEE:

YOUR MONEY BACK IN 5 DAYS
 If Ghirardi's Big 972-page **RADIO PHYSICS COURSE** doesn't teach you **RADIO-ELECTRONIC** fundamentals **EASIER, FASTER, and at LESS COST** than any other book or course.
YOU BE THE JUDGE!

diately televised back to headquarters. Enemy lines, retreats, advances, and other data may be flashed back to commanding officers.

As already mentioned, television has financial obstacles which it must overcome. The problem of sending clear, sharp images through space or by wire is a large one. Dr. Alfred N. Goldsmith, a famous engineer, has studied the possible costs of television entertainment production. As films may be used to a large extent, motion-picture costs were compared with radio costs. It costs about \$120,000 for an hour of movie entertainment. It costs about \$2,500 for an hour's fun and song by radio. Obviously, television cannot proceed at the radio rate of consumption and at the film cost of production!

No matter what plan is evolved (there are several possible ones) such as the continuation of the present system of programs sponsored by advertisers; or programs supported by taxes on receiving sets (which is done in England and Canada); or programs supported wholly or in part by the Government; or any combination of these methods, the cost will be higher than radio costs.

The solution to this particular financial problem seems to lie in finding cheaper program material—such as cheaper methods of producing pictures, use of radio studios, stage and vaudeville entertainment, and educational programs. It is also possible that television entertainment may not be continuous—as is radio. It may be just offered at certain set periods—such as a few hours nightly, as in the theater.

The other major financial difficulties are the cost of building stations, transmitting programs, of relay stations, wire systems, and last, but never least, the cost to us—the well-known ultimate consumer.

If our large radio companies believe that television will be the future of their business, they will find some way to pay for the cost of equipping and maintaining stations. The other cost, a possible selling price of \$250 or so, for receiving sets is a horse of a different color. It is a serious question as to how many of us could afford \$250 for a set—even if purchased on the installment plan. Perhaps that is possible during wartime conditions—but who can tell what conditions will be like after the war? In any case, if television sets were manufactured in large quantities, it is entirely possible that sets could sell at a much lower figure than \$250. This, of course, is something to be worked out by the manufacturers.

Television, of course, will be primarily a source of entertainment—just as the radio and movies. But it will also be an educational medium of considerable importance. Obviously, it will aid in the spread of farm and general information. It will also help the teacher and the student. A professor at the University of Iowa has demonstrated conclusively that tele-

vision can be utilized in the classroom. Lectures on such subjects as astronomy, botany, art and shorthand were supplemented with television pictures of material pertaining to these lectures. The class in astronomy saw pictures of constellations "televised" to a screen in the classroom; shorthand students saw the hood and line symbols televised.

We can only guess what the post-war world will bring us in the way of television, but one thing we can be sure of—scientists are even now working to bring that achievement to a reality.

-50-

Practical Radio Course

(Continued from page 48)

it. The so-called *voice-coil impedance* specified is usually that impedance which the speaker shows at some middle frequency (400 or 1000 cycles), or else it may be an average of the impedance variation over some middle range of frequencies. Accordingly, no speaker can be "matched" to an amplifier at all frequencies. Moreover, the speaker impedance usually increases abruptly and appreciably at the several resonance points in its response range. If an amplifier has a high output plate resistance, as will be the case if pentode or beam tubes without feedback are used in the output, the variation of plate circuit loading due to either of these causes will result in distorted response. However, with inverse feedback greatly reducing the value of the plate resistance, these variations can be made to have little or no effect on the amplification obtained.

In addition, it often becomes necessary in the field, to mismatch a speaker load to an amplifier, because the proper impedance taps are not available on the amplifier. A feedback amplifier can tolerate appreciable mismatching of this kind without difficulty.

In a multiple-speaker P-A system, if loudspeakers are cut in or out of the circuit the impedance reflected to the primary of the output transformer will change, causing variations in the voltage developed across it. For example, if two 8-ohm voice coils are connected in parallel across a 4-ohm output tap, a certain impedance will be reflected to the primary. Now, if one of the loudspeakers is removed from the circuit, the effective impedance of the primary will be doubled, and a higher signal voltage will be developed across it. Consequently, a greater voltage will be fed back through the inverse feedback circuit and the gain will be reduced, tending to keep the power output of the amplifier at a constant level. This property of inverse feedback amplifiers greatly facilitates loudspeaker switching problems and makes the use of artificial loads unnecessary provided the load is not permitted to vary over too wide

These 2 GHIRARDI BOOKS Will help you to Diagnose, Locate and Repair Receiver Troubles EASIER • BETTER and FASTER



ALFRED A.
GHIRARDI

Ghirardi's
Famous

MODERN RADIO SERVICING

The book that trains you quickly to MAKE MORE MONEY and get a bigger job as a Radio-Electronic repair technician BECAUSE it is by far the largest, finest, most easily understood how-to-do it training course on the subject!

Test Instruments—Troubleshooting—Repair

"Modern Radio Servicing" is the only single, inexpensive book that gives you a thorough training in the construction and working of all types of test instruments; receiver troubleshooting procedure; circuit analysis; testing, repair, and replacement of individual receiver parts; installation; adjustments, maintenance; service shop management, etc.

No other book can compare with this one for complete, easily understandable instruction on every phase of service work. "I recently finished a course in Radio Repair at one of the N. Y. radio schools and all my learning at this school did not help me to understand and repair radios as quickly as did this one book. I made my money back on one job alone!" writes Henry Miller of Brooklyn, N. Y.

You, too, can get a thorough and practical working training in Radio-Electronic servicing from this famous Ghirardi book—by yourself, in spare time at home—just as Mr. Miller and thousands of others have done. Its 1300 pages and 706 illustrations help you visualize every action. The 720 self-testing review questions help you check your progress. Progress as fast as you want to. It's the biggest servicing training bargain you can buy anywhere. You are protected completely by our

5-DAY MONEY-BACK GUARANTEE

SPECIAL MONEY-SAVING COMBINATION OFFER!

Both books for only \$9.50
(\$10.50 foreign)

A total of OVER 2,000
PAGES of the world's most
helpful and profitable servicing
information!

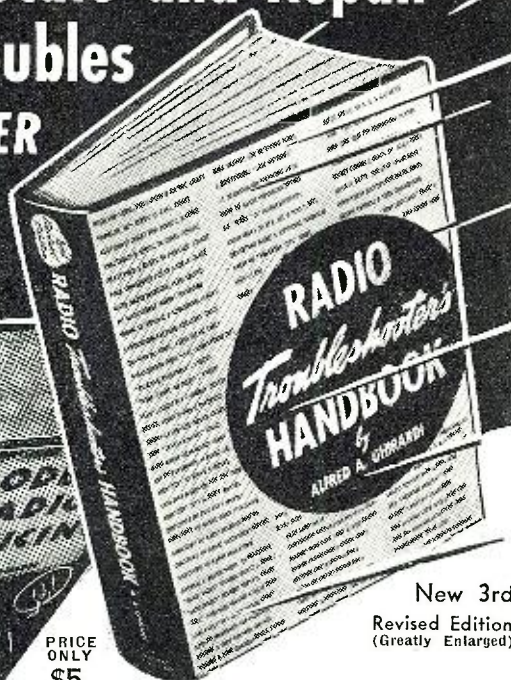

New 3rd
Revised Edition
(Greatly Enlarged)

PRICE
ONLY
\$5
EACH!

and the New Manual Size RADIO TROUBLESHOOTER'S HANDBOOK

744 big pages, chock-full of just the kind of time-saving, money-making, tabulated and charted servicing data that servicemen are finding invaluable.

MAKE MORE MONEY— HERE'S HOW TO TEST A RADIO IN 2 MINUTES or less!

Ghirardi's RADIO TROUBLESHOOTER'S HANDBOOK isn't a "study book." It's an on-the-job data book to be referred to in your everyday work. For example, don't waste your time on complicated troubleshooting for every ailing receiver you are called upon to repair! First, look up its model number in the big Trouble Case History Section of the Handbook which lists common troubles and their remedies for over 4,800 models of receivers and record changers.

CHOCK-FULL OF SPEED-UP DATA

Nine times out of ten the Handbook will give you the exact clue you need to repair a receiver at once—often without any testing at all! Similarly, on tubes, parts, replacements, substitutions, color codes, circuit alignment, a t.u.o radio, batteries, vibrators, ballasts, grid bias resistors, condensers, transformers, tone controls, filters, etc., you get pages of quick-find, tabulated data to help do every repair job better—AND A LOT FASTER! This big new Handbook that weighs over 4 pounds is yours to use every day to make more money for only \$5 complete (\$5.50 foreign) and our Money Back Guarantee protects you. Order today!

MAIL THIS COUPON NOW!

RADIO & TECHNICAL DIV. of Murray Hill Books, Inc.,
Dept. RN-34, 232 Madison Ave., New York 16, N. Y.

Enclosed find \$..... for books checked or, send C.O.D. for this amount plus postage (sent C.O.D. in U.S.A. only). If not fully satisfactory, I may return books within 5 days and receive my money back.

- Special MONEY-SAVING COMBINATION — Both books \$9.50 (\$10.50 foreign.)
 RADIO TROUBLESHOOTER'S HANDBOOK, \$5. (\$5.50 foreign.)
 MODERN RADIO SERVICING, \$5. (\$5.50 foreign.)

Name

Address

City (and Dist. No.) State

REPAIR ANY KIND OF RADIO EQUIPMENT
PREPARE FOR A BETTER JOB AS A RADIO-ELECTRONIC TECHNICIAN

We Can Deliver
TRANSFORMERS
In A Hurry!

If You Have Priority Rating

Priority deliveries of a few weeks instead of many months are now possible because of recent greatly increased production facilities.

Consolidated Radio Products Company manufactures a wide range of small and medium transformers, including Pulse Transformers, Solenoid Coils and Search Coils. Other products include Range Filters and Headsets.

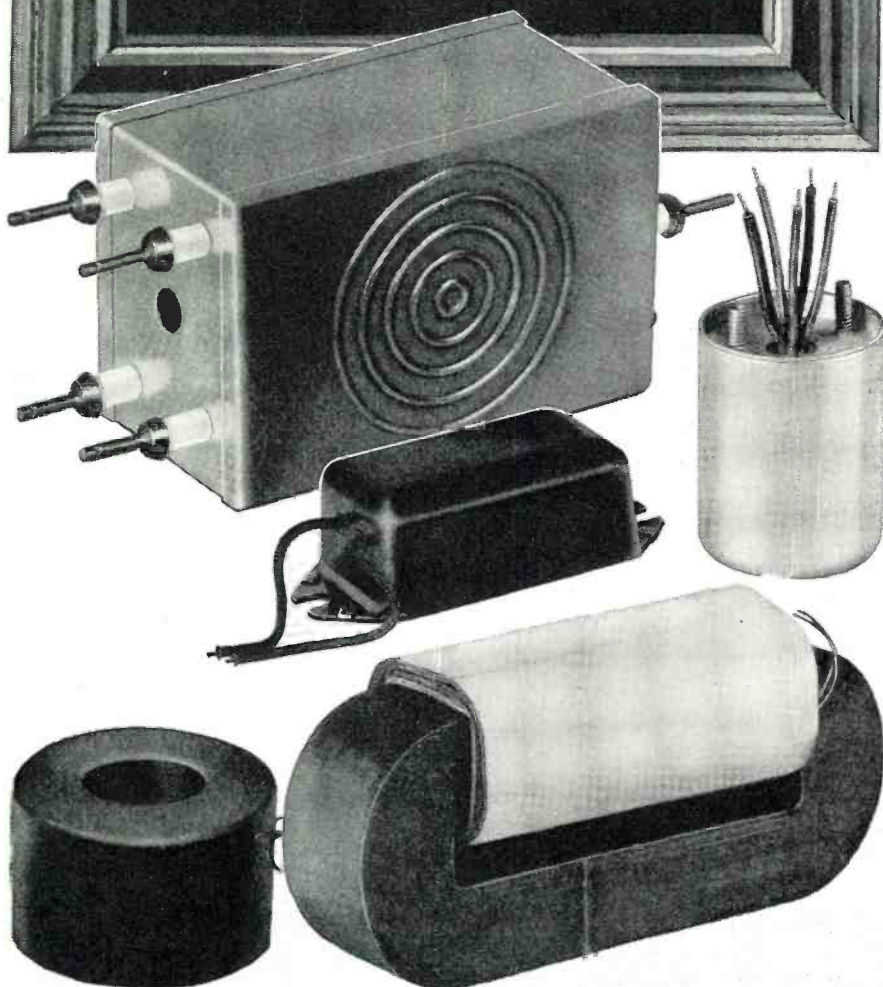
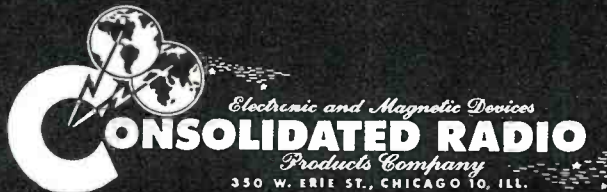

a range. That is, this type of compensation should not be expected to handle such extreme situations as that of a 4-ohm voice coil connected across a 500-ohm output for example, but within reasonable limits of load variation it will prove quite satisfactory. It is perfectly feasible to design a feedback amplifier so that a mismatch of 2:1 in the speaker load makes no apparent difference in the performance. This ability of feedback amplifiers to provide such self-regulating action of output level where the output load varies over such a wide range is greatly appreciated by P-A men in the field.

(To be continued)

Panoramic Reception

(Continued from page 37)

the signal going through this amplifier at any instant is the one which differs from the radio frequency oscillator frequency at that instant by 100 kc. Thus, as the oscillator frequency changes from 405 to 305 kc., frequencies from 505 to 405 kc. in the special I-F amplifier will be passed in succession through the panoramic 100-kc. intermediate-frequency amplifier. The output of this amplifier is rectified in the panoramic second detector, amplified once more and applied to the vertical deflection plates of the cathode-ray tube.

The cathode-ray tube operates by means of a beam of fast-moving electrons which strike a fluorescent screen in the front of the tube. When the tube is at rest, the electron beam appears as a single bright spot on the screen, but under the influence of external voltages applied to the tube's horizontal and vertical deflection plates, this spot is moved from side to side and up and down. When the movement of the beam is rapid enough and repeats itself often enough, it appears to be a continuous line or pattern on the screen.

In the Model S-35 Panoramic Adapter the horizontal movement of the electron beam is controlled by a sawtooth oscillator. Fig. 4A shows the output voltage of such an oscillator. Under the influence of this voltage the electron beam moves from left to right across the face of the tube and returns almost instantly to its starting position. The frequency of the sawtooth oscillator is approximately 20 cycles-per-second and at that speed the bright spot becomes a luminous horizontal line. The length of the line is adjusted by varying the voltage output of the sawtooth osc.

In addition to furnishing the horizontal sweep voltage, the sawtooth oscillator also controls the reactance modulator which varies the frequency of the panoramic radio frequency oscillator. This circuit is so arranged that at minimum voltage from the sawtooth oscillator the frequency of the variable radio-frequency oscillator is a maximum and at maximum volt-



TO EXACTING LABORATORY STANDARDS..

Quick and efficient comprehension of the production of laboratory equipment comes naturally to us of ECA. We're rich in the fundamental experiences arising from specialization in the development, design and manufacture of "tailored-to-order" radio and electronic equipment. Our facilities, geared to exacting laboratory standards, permit our engineers and technicians to approach a problem confident that the ultimate result will prove ultimately satisfactory.

An example of the work we do is the ECA Laboratory Oscillograph. This is a 7-inch, direct current, general purpose device built to provide features not ordinarily available in any commercial unit. This Oscillograph has seen continuous service in the ECA laboratory for more than a year, and it has been employed for such varied purposes as photographing transient phenomena, measuring time delay circuits, checking the fidelity of mechanical recorders and oscillographs, and so on.

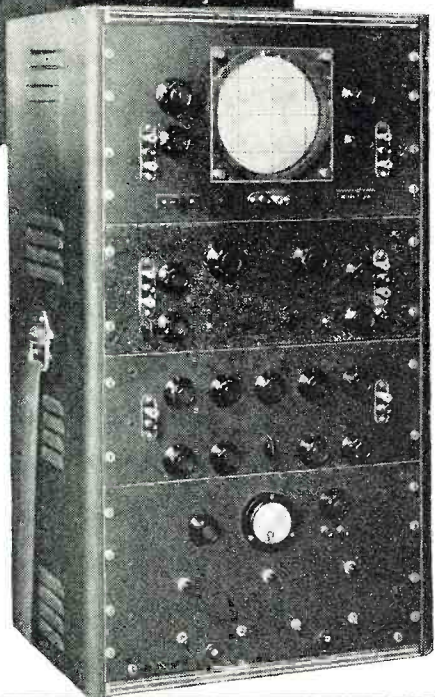

INVASION! This is no time for complacency. It's still necessary to buy War Bonds . . . still necessary to save scrap metal . . . still necessary to be a regular patron of the Red Cross Blood Bank . . . to hasten Victory and save lives.



ELECTRONIC CORP. OF AMERICA

45 WEST 18th STREET • NEW YORK 11, N.Y. • WATKINS 9-1870



*Centralized...
to Serve You
Efficiently!*

**LARGEST & MOST COMPLETE STOCKS
OF RADIO AND ELECTRONIC EQUIPMENT
Under One Roof**

You save *time* and *work* . . . you get *all* your needs faster . . . by dealing with this *one* central source. Here, under one roof, are concentrated the *largest* and most *complete* stocks of radio and electronic equipment . . . over 10,000 items . . . all leading makes. This means *rush delivery* on tubes, parts, kits, test equipment, public address . . . for training, research, engineering, production and maintenance.

Our close contact with all leading manufacturers assures latest supply data. Our veteran staffs help you with technical problems. This complete service simplifies procurement and expedites delivery of many diversified needs. The result is more efficient service to the Armed Forces, Government Agencies, Laboratories and War Industries. *Save time . . . Call Allied First.*

Write, Wire, or Phone Haymarket 6800

ALLIED RADIO CORPORATION

833 W. JACKSON BLVD., DEPT. 1-C-4, CHICAGO 7, ILLINOIS



**FREE
Today's
Most
Complete
Up-to-Date
BUYING
GUIDE**

**REPAIR AND
REPLACEMENT
PARTS
AVAILABLE
WITHOUT
PRIORITY**



**NEW Rapid R-F Resonance
and Coil Winding Calculator**

New, dual-purpose Calculator devised by Allied for fast and accurate determination of resonance factors and coil winding data. Simple, easy to use. Send for it now. No. 37-955.
Price net, only **25c**

6 VALUABLE RADIO BOOKS FOR 75c

Specially prepared by technical experts for radio training and for helpful reference. Priced only to cover cost of preparation and mailing.

RADIO BUILDERS' HANDBOOK. Simplified theory and projects. No. 37-750 . . . 10c

RADIO-FORMULAS & DATA BOOK. Handy, pocket-size manual. No. 37-752 . . . 10c

SIMPLIFIED RADIO SERVICING. Short cuts in troubleshooting. No. 37-755 . . . 10c

DICTIONARY OF RADIO TERMS. Easy-to-understand definitions. No. 37-751 . . . 10c

RADIO CIRCUIT HANDBOOK. Schematics and Pictures. No. 37-753 10c

RADIO DATA HANDBOOK Formulas — Tables — Charts No. 37-754 25c

ALL SIX BOOKS No. 37-799 75c

Write for Quantity Quotations



ALLIED RADIO CORP., Dept. 1-C-4
833 W. Jackson Blvd., Chicago 7, Illinois

Please send the following items (\$_____ enclosed)

- 37-750 37-752 37-754
- 37-751 37-753 37-755
- All 6 Radio Books Free Catalog Calculator

Name _____
Address _____
City _____ State _____



age it is a minimum. The amount of frequency variation can be adjusted by controlling the degree of reactance modulation.

Assume that the communications receiver is tuned to a signal on 5,000 kc. This signal will be amplified in the radio-frequency stages and will combine in the receiver first detector with the 5,455 kc. signal from the high-frequency oscillator. The important frequencies present in the output of the first detector will be 5,000 kc., 5,455 kc., 10,455 kc., and 455 kc. This latter signal will pass through the receiver intermediate-frequency amplifier and be heard in the speaker. It will also go to the special I-F amplifier of the panoramic adapter and be passed through to the first detector with relatively little gain. (See Fig. 3.)

The frequency of the panoramic variable radio-frequency oscillator is constantly changing from 405 to 305 kc. as the sawtooth oscillator goes from minimum to maximum and the horizontal sweep on the cathode-ray tube swings from left to right. When the variable radio-frequency oscillator passes through 355 kc., the output of the panoramic first detector will contain 455 kc., 355 kc., 810 kc., and 100 kc. This last frequency will pass through the sharply tuned 100-kc. panoramic intermediate-frequency amplifier, second detector, and video frequency amplifier and will appear as a narrow inverted "v" at the center of the screen, the horizontal sweep circuit having reached that point at the same instant that the variable radio-frequency oscillator reached 355 kc. (Note: Do not confuse the video frequency amplifier in the panoramic adapter with a television video amplifier which must pass a band of frequencies 4 to 5 mc. in width. In this case it is only necessary to pass a band of approximately 2 kc.)

At the same time that the 5000 kc. signal is being received many other signals are present in the input circuit. Assume another signal on 4950 kc. It passes through the radio frequency stages into the receiver first detector but at a much lower level as it is 50 kc. off resonance. It also combines with the output of the 5455-kc. oscillator to produce frequencies in the receiver first detector output of 4950 kc., 5455 kc., 10,405 kc., and 505 kc. None of these frequencies will pass through the intermediate frequency amplifier of the communications receiver but the 505 kc. signal will go through the special I-F amplifier of the panoramic adapter.

Referring to Fig. 3 it will be seen that this signal will be amplified to a much greater extent than the 5000-kc. signal (455 kc. at input of panoramic adapter), thus compensating for the loss of gain caused by its being 50 kc. off resonance in the receiver radio-frequency stages. This second signal appearing at 505 kc. in the first detector of the panoramic adapter will pass through the 100-kc.



PAINTED FOR ELECTRONIC LABORATORIES, INC., BY BENTON CLARK

Can a Vibrator Power Supply Rescue a Boat-Load of Men?

No . . . it can't! But it can help—and the rescue might be prevented and the boat lost forever, if just one vibrator power supply failed to do its job.

● The compact radio transmitter that is standard equipment in many lifeboats depends on a vibrator power supply . . . The patrol plane that picks up the SOS . . . spots the drifting boat, and summons surface ships with its own powerful transmitter, has a complex electrical system that includes many vibrator power supplies. And

in the rescue ship itself are still other vibrator power supplies performing vital functions.

The dependability of *E·L* Vibrator Power Supplies under all climatic conditions — their amazing adaptability in meeting specific current requirements — have brought them into wide use for radio, lighting, communications and motor operation—on land, sea and air.

Electronic's engineers have specialized for years in the technique of vibrator power supplies. They have conducted the most extensive research ever known on power supply circuits. They have extended the practical application of vibrator-type power supplies far beyond previous conceptions.

In the electronic era of peace to come, the efficiency and economy of *E·L* Vibrator Power Supplies will find new applications wherever electric current must be changed, in voltage, frequency or type.



Electronic

LABORATORIES, INC.

INDIANAPOLIS

E·L ELECTRICAL PRODUCTS — Vibrator Power Supplies for Communications . . . Lighting . . . Electric Motor Operation . . . Electric, Electronic and other Equipment . . . on Land, Sea or in the Air.

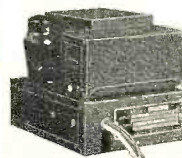

For Operating Radio Transmitters in Lifeboats — *E·L* Model S-1229-B Power Supply. Input Voltage, 12 Volts DC; Output Voltage, 500 Volts DC; Output Current, 175 MA; Dimensions, 7½" x 5½" x 6¼".

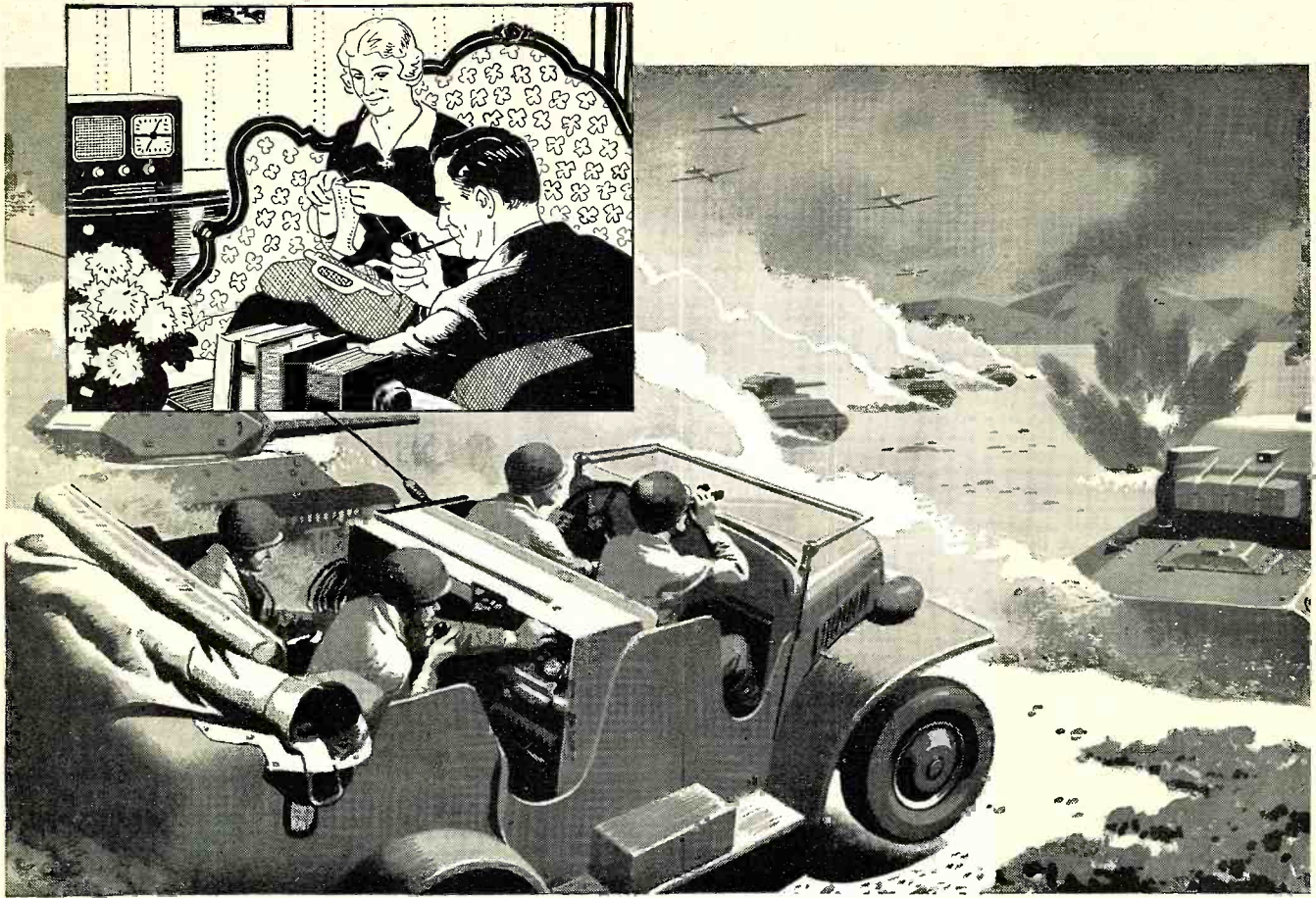

Fireside to Firing Line

It's a long way from fireside to firing line. Especially long for a radio set. For when you take this coddled precision instrument away from the peace and calm of a living room and stick it in a mobile unit at the front, you're really putting it "on the spot." Jolts, jars, concussions and extremes of temperature are the common lot of radio and electronic equipment in military service.

Fortunately, this transition was not as abrupt as it might have been, for Delco Radio technicians had tackled and solved similar problems in making automobile radios practicable. Vibration and shock . . . heat and humidity variations . . . electrical interference . . . shaking and bumping—all these obstacles were overcome one by one through the ceaseless experimentation and research of radio scientists.

With the conquest of the foes of *radio in transit* came far greater benefits than better entertainment. Years ahead of the second World War, the Delco Radio Division had solved many of the problems which intervehicular military radio would face. Years ahead of time, the "spirit of perfectionism" had prepared vehicular radio for its vital role at the battlefield.

Let's All Back The Attack!
BUY WAR BONDS

Delco Radio
DIVISION OF
GENERAL MOTORS

intermediate-frequency amplifier when the variable radio-frequency oscillator reaches 405 kc. As this occurs at the minimum point of the sawtooth oscillator output, the signal appears at the left end of the base line on the screen. Fig. 4B shows the screen with the two signals described above.

By similar reasoning it will be seen that any signal within the 100-kc. band width of the panoramic special I-F amplifier will pass through the adapter at the correct time to appear on the screen in its proper relationship to other signals.

The band of frequencies covered may be reduced by decreasing the action of the reactance modulator and if this is done while holding the amplitude of the cathode-ray tube's horizontal sweep voltage constant the signals in the center of the screen will spread and those on the edges will move outward and disappear. When adjusted for maximum band width, the signals are tall and narrow, amplitude-modulated signals fluctuating up and down and telegraph signals appearing and disappearing in synchronism with the keying. Frequency-modulated signals remain at a constant height but appear to change in width as side bands appear and disappear during modulation. As the width of the band being observed is decreased, the signals spread out and their individual characteristics may be more easily observed. If the action of the reactance modulator is decreased to zero so that only one station is visible on the screen, a simple wave-envelope pattern will appear.

The design of the automatic volume-control circuit in this equipment presented an interesting problem. An ordinary A.V.C. circuit is designed with a comparatively large time constant so that it will compensate for fading or for varying levels of signal strength as the receiver is tuned to different stations, but will not respond fast enough to suppress audio-frequency modulation. For example, if the lowest audio frequency to be received is 45 cycles per second, the time constant of the A.V.C. circuit must be .022 seconds or more.

A brief analysis of the scanning action of the cathode-ray tube will demonstrate the inability of an ordinary automatic volume control to meet the requirements of this receiver. The horizontal sweep covers the screen 20 times per second which means that at maximum band width, it scans 2000 kc. every second or moves 10 kc. in .005 seconds. Assume that a comparatively strong signal is present at some point in the band under observation and that a weak signal is located 10 kc. higher. As the 100-kc. amplifier in the panoramic adapter has a maximum band width of 2 kc., there will be no difficulty in separating the two signals but, if a standard A.V.C. circuit is used, the strong signal will reduce the gain and .005 seconds later when the sweep passes the weak signal, the gain will

From Lafayette Radio Corp's

Selenium Dry Disc Rectifier

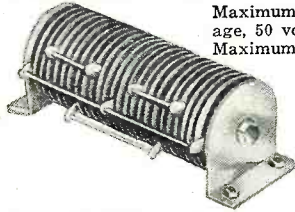

Maximum AC input voltage, 50 volts 60 cycle AC.
Maximum DC output current, 2.5 amps. 5 1/4" long, 1 13/16" high. 2" wide.
No. 1C10573
Each ..\$4.95

"Zip" Wire Stripper



A guaranteed wire stripper with pivoted blades that will strip insulation clean in one operation. An adjustable stop enables wire to be stripped to any length. Blades are suitable for any wire up to 12MM diameter. 2" Wide, 2" Deep, and 2 1/2" Long.
No. 1C15268\$1.19

Aerovox Metal Cased Bathtub Condenser



.1-1-1 Mfd. 400 Volt DC. Oil impregnated and oil filled. Riveted lug terminals. 1 3/4" x 1" x 1 1/8".
No. 1C2362 Each ...79¢

Gang Switch

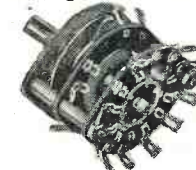

Two-gang shorting type switch. 4 pole, two position per gang. Bakelite insulation. 1/4" diameter standard shaft; 3" long.
No. 1C12666 Each...47¢

R.C.A. 6" PM Speaker



5-ounce magnet. Handles 4 to 6 watts of audio, without distortion. Comes with transformer for single beam power output tube.
No. 1C19430 Each..\$2.95

CLAROSTAT 3 Ohm 25-Watt Power Rheostat



Handles maximum current through entire resistance of 2.880 amps, and will handle current of 4.320 amps in up to 1/3rd of its resistance. Clarostat PW-25-4W.
No. 1C6839\$1.95

Arsenal
of

RADIO AND ELECTRONIC EQUIPMENT

Special Values!

CONDENSERS — 10-20 Mfd. 350 V. D.C.-5-5 Mfd. 150 V. D.C. Upright. No. 1C236979¢
TUBE CAPACITORS — 8-8 Mfd. 600 V. Plug-in type. No. 1C2330\$4.45
IRC RESISTORS — 150 Ohms, 50 Watts. W.W. Variable. No. 1C528688¢
IRC RESISTORS — 20M Ohms, 50 Watts. W.W. Variable. No. 1C528797¢
IRC RESISTORS — 3500 Ohms, 80 Watts. W.W. Variable. No. 1C5196\$1.15
RENEWABLE FUSES — 3 Amps. 1C-12375. 6 Amps. No. 1C12376...32¢
SHURE MAGNETIC RECORDING HEAD — Replaces crystal cutters. No. 1C13799\$4.95
LEACH 4-POLE RELAY Heavy Duty—110 V. A.C. Coil. No. 1C14251\$3.95
RELAYS—SPST Contacts normally open. 6 V. A.C. Coil. No. 1C-14306.....93¢
RELAYS—SPST Contacts normally closed. 110 V. A.C. Coil. No. 1C14308\$1.17
MIDGET RELAYS — SPST Contacts normally closed. 110 V. A.C. Coil. No. 1C14307\$1.00
MIDGET RELAYS — DPST Contacts normally open. 110 V. A.C. Coil. No. 1C14309\$1.30
RELAYS—SPST Contacts normally open. 1 set closed. No. 1C14310..\$1.97
STEPPING RELAYS—6 V. D.C. 11 pos. 3 mounted switch sections. No. 1C1425059¢
ICA OSCILLATOR, Mod. No. 4300 — Code practice set, keying monitor. No. 1C14086\$11.76

Urgent! Donate a Pint of Blood to the Red Cross Today

LAFAYETTE RADIO CORPORATION

901 W. Jackson Blvd., Chicago 7, Ill. • 265 Peachtree St., Atlanta 3, Ga.



Free!

THE ONLY UP-TO-DATE CATALOG IN THE FIELD. From cover-to-cover... a treasure house of radio and electronic parts and equipment... contains invaluable information on how to obtain needed items without delay. MAIL THIS COUPON

LAFAYETTE RADIO CORP.
901 W. JACKSON BLVD., CHICAGO 7, ILL., DEPT. E-3
Please send me a FREE copy of the new Lafayette Radio Corporation Catalog No. 94.

NAME
ADDRESS
CITY..... STATE.....



The
Worlds
KEENEST
Radio Ears

MURDOCK RADIO PHONES

IN extra sensitivity, durability and clearness of reception, MURDOCK Radio Phones have been outstanding for 40 years. Now they are giving superior service to our fighting men — under the toughest operating conditions!

To meet the exacting demands of war, this famous Headset has been further perfected. Today it represents science's latest advance in radio communication. The outstanding performance of MURDOCK Radio Phones will be a decided asset to YOU when business resumes post-war competition.

We Welcome Sub-Contract Work
Our busy plant still has facilities for making more Radio Phones and related parts — on a sub-contract basis. Can we help you in this field? Please write us!

Write for Catalogue!

WM. J. MURDOCK CO.
124 Carter St., Chelsea 50, Mass.

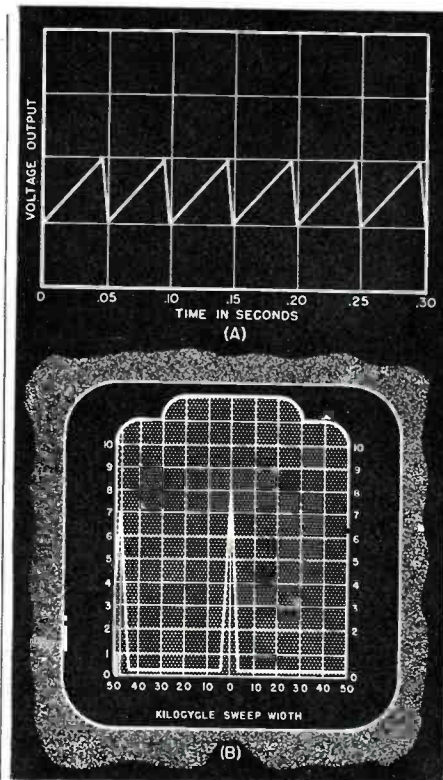

Fig. 4. (A) Output voltage graph of sawtooth oscillator. (B) Screen of cathode-ray tube showing two signals.

still be reduced and no signal will appear.

The solution lay in designing a double A.V.C. system. A.V.C. voltage is taken from the diode second-detector of the panoramic adapter in the usual manner but two filter circuits are provided. The first A.V.C. filter has a time constant of .022 seconds, which enables it to compensate for all variations of carrier level of more than .022 seconds duration. This circuit is connected to the panoramic special I-F amplifier and controls the over-all gain. The A.V.C. voltage is also applied to another filter with a time constant of 235 micro-seconds which is connected to the 100-kc. intermediate-frequency amplifier. With the panoramic adapter adjusted for maximum frequency coverage, the electron beam will scan a band of only 470 cycles in that period of time and it is evident that this second A.V.C. can easily adjust the amplitude of signals separated as little as 2 kc., the band width of the amplifier.

The extremely fast action of the second A.V.C. filter made it necessary to provide a panel operated control for the degree of A.V.C. action. As this circuit can adjust itself to changes of carrier level occurring only 235 micro-seconds apart it will obviously suppress all modulation frequencies below 4,255 cycles:

$$f = \frac{1}{T} = \frac{1}{235 \times 10^{-6}} = 4,255 +$$

When amplitude modulation or other similar phenomena are being observed, the A.V.C. action can be reduced to the desired level by means



*What we are
fighting for...*

A war correspondent in the Solomons asked a tired marine what he thought he was fighting for. The marine's face lit up.

"Gosh," he whispered, "what I'd give for a piece of blueberry pie!"

To that marine "blueberry pie" summed up the democratic way of life . . . the dates . . . the movies . . . the ball games . . . home cooking . . . warm family ties . . . and the joy of walking in the woods without fear of a lurking sniper.

Homely things like these are what we are all fighting for . . . the soldier in his job . . . you in your job . . . we in our job of building dependable Kenyon transformers as fast as we know how.



THE MARK OF

EXCELLENCE

Most of us can hurry the day when that fighting marine can have his pie. We can buy an extra dollar's worth of bonds this week . . . give a pint of blood every few months . . . save scrap metal, rubber and rags . . . and we can stay on the job every day, all day.

Let's not let the boys wait for their pie a minute longer than they must.

KENYON TRANSFORMER CO., inc. 840 BARRY STREET
NEW YORK, U. S. A.

CONNECTORS • CABLES • PLASTICS

for Electronics



- ★ A-N Connectors—Plugs and Receptacles—all sizes—all styles—built to Army-Navy specifications.
- ★ Cable Clamps—bushed and plain in all sizes—A-N approved for all types of open wiring assemblies.
- ★ Gun Firing Solenoid, Automatic Grounding and Short Circuiting Connectors for special requirements.
- ★ Pressure-Tight — Explosion-Proof — Light-Proof Connectors and others for special applications.
- ★ Conduit Fittings, A-N approved—all types for use with solid and flexible A-N conduit.
- ★ Low-Loss Connectors—coax and twinax types for high frequency and micro-wave installations.
- ★ British Type Electrical Connectors serving requirements approved by the British Air Ministry.
- ★ Radio Parts—plugs, receptacles, sockets, connectors, microphone equipment, and electronic devices.
- ★ Conduit in all sizes—durable construction in flexible aluminum and synthetic covered flexible aluminum.
- ★ Low-Loss Solid Dielectric Coax and Twinax Cables in sizes built to the new Army-Navy specifications.
- ★ Beaded Type Coax and Twinax Cables of Polystyrene and Mica-Filled Bakelite for critical requirements.
- ★ Synthetics for Electronics—sheets, tubes, rods, and custom-machined Polystyrene.

Everything—Component parts for conduit and wiring assemblies, or, if desired, complete harnesses and multiple wire assemblies, including connectors, conduit, fittings, and attachments built to specifications.

For conscientious fulfillment of your requirements for today's production—for cooperation in your plans for tomorrow—depend on Amphenol!

AMERICAN PHENOLIC CORPORATION
CHICAGO 50, ILL.

★
IN CANADA
AMPHENOL LIMITED
TORONTO

★



of Resistor R₁ in the schematic diagram.

Many practical applications of panoramic reception will readily occur to the experienced radio man. Its value in monitoring the various frequency bands is obvious and becomes even more apparent when it is known that weak signals that could easily be missed in the noise and "static" of normal loudspeaker reception are plainly visible on the screen. When such equipment is once more available, the marine services, airlines, amateurs and all who have occasion to look for signals over a wide range of frequencies will find Hallicrafters Panoramic Adapter a revolutionary improvement in their work.

—30—

Jungle Broadcast

(Continued from page 39)

the Buna campaign who directs jungle training for Mobile Force, whipped out his pistol, pointed it in the air near the mike, and pulled the trigger. Weathers still hopes it sounded like a pole charge destroying a Jap-type pillbox.

The announcer-sergeant had another, but non-technical, problem. His first speaker was Lieutenant General George H. Brett, head of the Caribbean Defense command, and the second was Major General E. F. Harding, Mobile Force commander, and a veteran of the Buna campaign. Both have reputations as genial generals, but the average soldier may be in the army for many months without ever seeing as much as a brigadier. After the brief experience with his prominent guests, however, handling ordinary captains and lieutenants held no worries and Weathers lost the only slight case of jitters he has had around a mike in years.

Sergeant Bras had nothing to contend with higher than a lieutenant colonel who led a group of swimmers through a wall of blazing gasoline, and a nautical private who insisted on putting "hello, mom" into the script.

However, Bras and Sgt. George Odom, a KSFO (San Francisco) man before the war, were "sweating out" another problem. It was their mike. Five minutes before they were to go on the air, Bras and Odom went through a final checkup. Odom claims that what came out was the most silent silence he has ever heard. They made a quick check of the connections, found everything in order, tried again, and still got no sound. More from disgust than from any hope of success, Chuck jiggled the microphone, and the final test was made. The "one, two, three, four" came through; everything was all right again, and, except for wondering if the mike would go out sometime during the remaining 10 minutes, there was no "hitch" in the entire 75-mile-plus setup.

RADIO NEWS

Bras' soft voice told its story: jungle swimmers wearing full equipment swimming across the river—through fire—supporting troops going over in boats, ammunition and mortar fire with its soldier-director screaming "On the way!! On the way!!!"

"... the Army Hour returns you from the jungles of Panama to the United States in New York," the Q line answered "Thanks, Panama, that was swell," and it made it all worth it.

But, as Odom, Bras, Weathers, Wyberg and Braymes left the Mobile Force training area, they mused over a line which Private Bill Osborne of Hinton, W. Va., had said when called to the Mike: "I used to think that the jungle was something that nobody but Tarzan would go into, but I know different now."

"Tarzan was smart," Bras explained dryly. "He traveled in the trees."

They left, speculating on what Lord Greystoke would have done about hauling all that radio equipment back where they got it.

-30-

Mine Locators

(Continued from page 34)

electrical fields is disturbed and the instrument is useless.

The initial orders for the detector were placed with various firms in Britain's radio manufacturing trade. The creation and adjustment of an electrical field is not a difficult job in theory. Production of the equipment for use in the field is another story.

All sorts of difficulties that the layman would not ordinarily anticipate were encountered. Take, for example, the wax that holds the coils in position. The War Office specified that the equipment must be for use in both tropical and arctic ranges of temperature. The trouble about wax with a high melting point is that under conditions of severe frost it cracks and shrinks. If the wax moves even so much as one-thousandth of an inch the coils come out of adjustment and the detector is useless. Contrariwise, a wax which will not crack in severe cold has a low melting point and will melt in the tropics.

The heaviest and most critical period in the evolution and production of the electrical mine detector was in June of 1942 for most of the detectors which had been stored in reserve in the Middle East were lost when Tobruk fell. They had to be replaced as quickly as possible. And replaced they were. But the reorganization involved in drastically stepping-up the output to make good the losses was considerable.

Yet, largely by the unstinting efforts of the girls who assemble the weapons, the deficit was made good.

-30-

March, 1944

LEADERSHIP—TO THE FUTURE of Electronics

Building in unlimited quantities vital electrical and high frequency equipment—advancing engineering design—enlarging its manufacturing facilities—speeding production—Amphenol is producing to the utmost to meet today's urgent requirements. On this experience Amphenol Products will set new standards of performance, economy, and service in peacetime electronic applications.

OK METHODS

Ready for distribution now is the first issue of a new Amphenol booklet, OK METHODS—a 28-page illustrated manual which provides an exchange of ideas in wiring assembly.

OK METHODS outlines tested procedure in assembly of wire and connectors—presents an easy means of instructing large groups of operators in standardized work procedure. OK METHODS is clearly written—profusely illustrated. Write for your copy today.



AMPHENOL CATALOG

Amphenol Catalog #70 is the leadership catalog of the industry. It covers A-N Connectors and other electrical equipment used on aircraft, radio, ships, and tanks. The listing includes charts and technical data on A-N and British Type Connectors, A-N Conduit, A-N Conduit Fittings, Low-Loss Connectors and Cables, Radio Parts and Accessories, Special Tools and Equipment, Synthetic Sheet Rod and Tubing.

Write for your copy on your company letterhead.

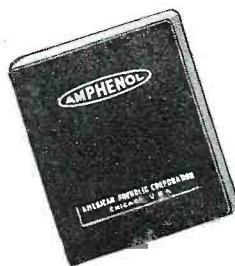

Plant of American Phenolic Corporation devoted entirely to the design and manufacture of Amphenol quality products.



AMERICAN PHENOLIC CORPORATION
CHICAGO 50, ILL.

★
IN CANADA—
AMPHENOL LIMITED
TORONTO
★

Electro-Optics

(Continued from page 28)

economy. The optical engineer, on the other hand, holds these of secondary importance and is more interested in the physical characteristics of light sources. Before applying a given lamp the optical engineer must consider its size, shape, intrinsic brightness, and type of emission. Thus, in many cases, a light source chosen in deference to the optical system may not be the most economical from the operational point of view.

The criterion by which all light sources possessing a continuous spec-

trum are judged is the black body. A black body is a source whose radiant flux in all parts of the spectrum is the maximum obtainable for any source operating at the same temperature. Its origin lies in a study made by Kirchoff of the characteristics of substances like lampblack, deep-piled velvet, and many other materials. This investigation showed that while these materials absorbed greater amounts of radiation than others, they were, at the same time, better radiators when heated to incandescence. Kirchoff stated, therefore, in a law that bears his name, that the emissive power of a body is directly proportional to the ability of that body to absorb radiant energy incidental upon

it. No known substance is truly black in this sense, even lampblack reflects about one percent of the radiation falling upon it. The desired condition can be approximated by a cavity with opaque walls at a uniform temperature and with a small hole for viewing purposes (Fig. 5). It can be seen that if the size of the hole is small compared with the size of the enclosure, any radiation entering the enclosure will be reflected and re-reflected time and again until it is completely absorbed by the walls. This being so, then the radiation from such a body should be practically identical with that from an ideal black body.

A spectral energy distribution curve is the correlation of the radiant energy emitted throughout the spectrum to the wavelengths (or frequencies) of that spectrum. The spectral energy distribution for blackbodies at various temperatures are shown in Fig. 6. As can be seen, the maximum of the curves shift progressively towards the short-wave end of the spectrum as the temperature is increased. That this is true can be verified by the common observation that a heated body becomes first a dull red, then, as the heating is continued, progressively orange, yellow, and finally white. The color progression is towards the short-wave end of the spectrum.

Since the color of a light source is associated with its temperature, color has become a means of comparing different light sources. The basis of this comparison is a quantity known as color temperature. The color temperature of a source of light is that temperature at which a black body must be operated to give a color matching that of the source in question. (It should not be confused with the true operating temperature of the source, however.) Color temperature is expressed upon the Kelvin scale. The Kelvin temperature is obtained by adding 273.1 to the Centigrade temperature. The Centigrade scale is one that has taken the freezing point of water as 0° and the boiling point of water as 100° and has the intervening space divided into 100 equal parts. The Kelvin scale has for its zero absolute zero, or the lowest temperature physically obtainable. It so happens that this point is at -273.1°C. Table I lists the color temperature of some of the more common sources of radiation.

Through use of filters, a light source of any given color temperature can be made to appear like a source of another color temperature. These filters may be of dyed gelatine, colored glass, or of colored solutions. Of them all, the liquid filters provide the most precise means of adjusting color temperature and have been accepted by international agreement for this work. These liquid filters were devised by our National Bureau of Standards and their construction is given in a paper by Davis and Gibson.⁴

⁴ Davis R., and Gibson, K. S., Bureau of Standards Miscellaneous Publication No. 114, Jan. 1931.



Bring your Pincor service problems to us . . .
but please bring only Pincor problems; there
just aren't enough hours in the day to take
care of any others.

GENERATORS . . . DYNAMOTORS . . . CONVERTERS . . .
D C MOTORS . . . POWER PLANTS . . . GEN-E-MOTORS

PIONEER GEN-E-MOTOR

5841 WEST DICKENS AVE., CHICAGO 39, ILL.
Export Address: 25 WARREN ST., NEW YORK 7, U.S.A.
Cable Address: SIMONTRICE, NEW YORK

BUY MORE BONDS!

PINCOR
Products

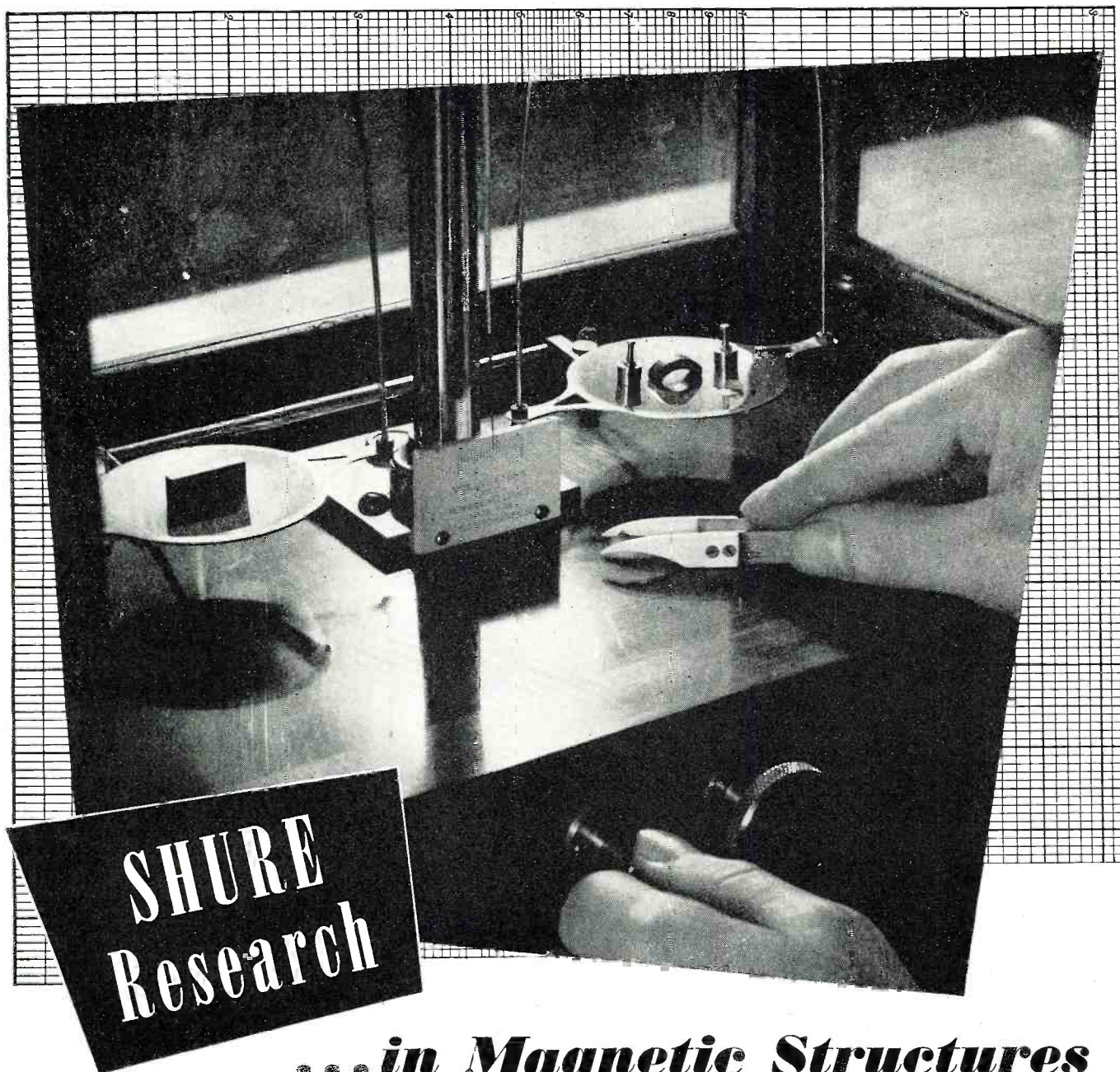

... *in Magnetic Structures*

By the time we finish our present contract for headphones, Shure Engineers will have effected a $3\frac{1}{2}$ ton saving in critical magnetic alloys. Redesign of the magnetic structure effected a saving of three-quarters—so that, today, the magnetic material generally required for one headphone is now enough for four headphones. This has been accomplished with full maintenance of the operating characteristics with the added advantage of decrease in weight. Shure Engineering continues to lead the way to better microphones and headphones for your postwar needs.

SHURE BROTHERS, 225 West Huron Street, Chicago
Designers and Manufacturers of Microphones and Acoustic Devices



So far the discussion upon light sources has been centered upon those with a continuous spectrum, viz., incandescent filaments. This is justifiable since the tungsten filament lamp is the most commonly used. There are other sources, however, upon whose characteristics many optical instruments are dependent. The electric arc is one of these.

The carbon arc is probably familiar to many because of its formerly widespread use for street illumination. The spectrum of the pure carbon arc is continuous and the light from it, although dependent upon the current at which it is operated, has a color temperature in the neighborhood of 3700° K. Most of the light emitted is supplied by the positive crater. The arc

stream can be made to contribute more to the radiation by drilling the electrodes and coring them with certain inorganic chemical compounds. It is in this way that the white-flame arc (the Klieg light) is obtained. A similar procedure is sometimes used in spectrographic analysis, but then the core material is that being analyzed.

Other metallic arcs (and sparks) are used in spectrographic analysis. Practically all metals and alloys can be very accurately analyzed by the simple expedient of making arc or spark electrodes of the material in question.

The mercury arc is another commonly used source of light in optics. Its chief virtue is that it possesses widely separated spectral lines which

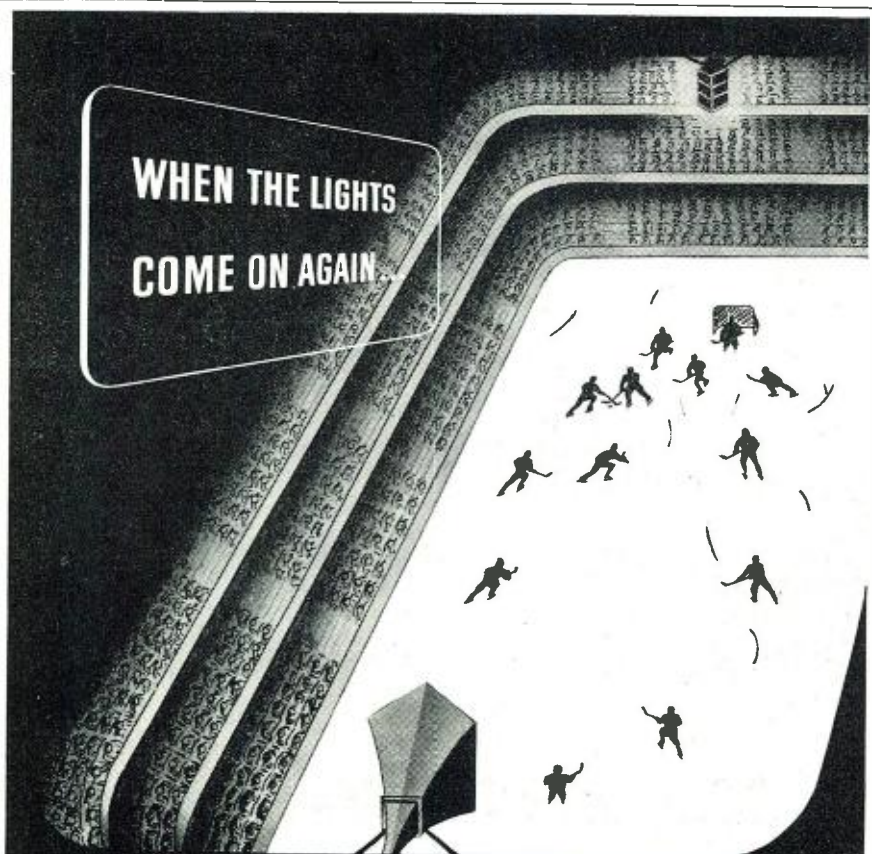

AUDIOGRAPH

THE FIRST NAME IN SOUND

When sports are again "big news," Audiograph will add immeasurable pleasure by its intelligible interpretation of every play. Audiograph, for sound amplification—a necessity of the future—bears a name already honored. It is destined to increase your sales in a field of expanding importance.

JOHN MECK INDUSTRIES
PLYMOUTH, INDIANA



TABLE I

Color temperatures of common sources of radiation.

BRITISH STANDARD	
CANDLE	1880°K
KEROSENE FLAME	2055
GAS FLAME, BAT'S WING	
WING	2160
ACETYLENE	2415
CARBON FILAMENT LAMPS	
50W untreated carbon	2080
50W GEM carbon	2195
VACUUM TUNGSTEN FILAMENT LAMPS	
10W	2390
25W	2493
40W	2504
60W	2509
GAS-FILLED TUNGSTEN FILAMENT LAMPS	
40W	2760
100W	2865
500W	2960
OTHER SOURCES	
250W Photoflood	3444
Photoflash, No. 20	3500
Solid Carbon Arc	3780
White-flame Carbon Arc	5000
Mean Noon Sunlight at Washington, D. C.	5400
Overcast Sky	6500
Skylight	12,000-25,000

Values obtained from published works of Forsythe and collaborators as quoted by Clark. "Photography by Infra-Red," p. 122.

can, by use of the proper filters, be used to provide intense monochromatic light. Low-pressure arcs are preferable for this work. The recently introduced high-pressure mercury arcs are less desirable even though they provide much more light because they possess, due to their high pressure, a continuous spectrum as a background to the characteristic mercury lines. The high-pressure arcs have been found to be extremely useful, however, as a source of light in searchlights and airway beacons. It is claimed that some of these lamps even outshine the sun in brilliance.

It may not be amiss to mention here a precaution necessary whenever one works with exposed arcs. First of all, the arcs have a strong erythematous effect; that is, they possess a capacity to produce a temporary reddening (sunburn) of the human skin. Thus, if unprotected one is liable to be severely burned. In the second place, the eye is extremely sensitive to ultraviolet rays, in which these sources are rich, and is likely to be harmed by them. The symptoms of such harm is the feeling that one has sand in his eyes. It is well-worth wearing protective goggles to avoid experiencing this feeling. The goggles need have



"In recognition of Service beyond the call of duty . . ."

In this grim business of war, the men in uniform take the risks; they deserve the decorations.

We tube manufacturers don't expect medals. When, however, credit does come our way . . . and when it comes from such a man as Paul V. Galvin, President of RMA . . . it makes us mighty proud and happy.

"Let me take a moment for special mention of the tube engineers. Too often they are not fully recognized. We see fine accomplishments in apparatus, but we fail to appreciate the important work that has been done be-

hind the scenes by the tube engineer. Hats off to you—your accomplishment has been most extraordinary. But you, also, you cannot as yet rest upon your oars. The job is not finished, and new and additional accomplishments are required before we are finished with this war." *

Hytron engineers realize fully that "the job is not finished", and they continue to strive for "new and additional accomplishments" needed to win the war. Their aim is to develop better tubes to make possible better fighting equipment—let the decorations fall where they may.

* Excerpt from address of Paul V. Galvin, president of the Radio Manufacturers Association at the Institute of Radio Engineers' Rochester Fall Meeting, November 9, 1943.

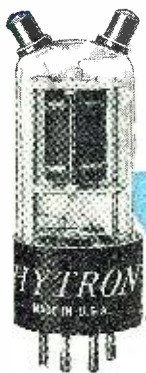

OLDEST EXCLUSIVE MANUFACTURER OF RADIO RECEIVING TUBES

HYTRON
CORPORATION
ELECTRONIC AND RADIO TUBES
SALEM AND NEWBURYPORT, MASS.



BUY
ANOTHER
WAR BOND

no more than clear glass lenses, although absorptive lenses would be better. Another reason for wearing protective goggles is that these arcs, with the possible exception of mercury, are also rich in infrared rays which are held responsible for certain other injuries and degenerative changes in the eye. Glass will absorb much of the infrared and avoid these difficulties. In short, protective goggles are the best insurance against eye injuries when working with unshielded arcs.

EDITOR'S NOTE: Additional articles on other phases of Opti-onics are being planned and will appear in following issues. Articles that have been scheduled are: Additional fundamentals of Opti-onics, Colorimetry and Radiometric elements.

-30-

Frequency Standards

(Continued from page 32)

disappear, leaving the speech or music clear. With a small amount of practice, this adjustment can easily be made.

Zero-beat adjustments may be made more easily during the short intervals between renditions and announcements when the carrier is clear of all modulation. However, fast movement is necessary on the part of the operator, since the carrier is purposely not left unmodulated very long at a time. When beating against an unmodulated carrier, ability to detect exact zero beat will depend largely upon the low-

frequency reproducing ability of the receiver and amplifier. Some receiver systems tend to cut the low frequencies, giving no response whatever over an audio band covering twenty cycles or so on each side of actual zero beat. Increased accuracy is obtainable in this case by observing an output voltmeter, connected across the speaker voice-coil terminals, rather than listening to the beat note. The pointer of the meter will cease to pulse at exact zero beat. However, the meter system is useless with a modulated broadcast carrier.

If after the closest possible zero beat adjustment has been made, it is desired to correct for error in the receiver carrier frequency, a telephone call to the broadcast transmitter plant will usually enable the experimenter to ascertain the exact deviation of the broadcast station frequency from assigned value at the moment.

-30-

Square-Wave Generator

(Continued from page 31)

half-cycles of input voltage, the diode cannot conduct and no current flows through R_2 . As a result, the voltage drop across R_2 is pulsating. The control grid of pentode V_2 is connected to the top of R_2 , so receives large negative pulses.

The pulses impressed upon the grid of V_2 reduce the plate current of that tube to zero. This blocking action accordingly develops a voltage of reasonably square waveform across resistor R_3 , and this same voltage is delivered to the output terminals, T_3 and T_4 , through C_3 and R_5 which possess a large time constant. For operation at 60 cycles, C_3 is 4 microfarads, R_5 100,000 ohms.

The waveform of the output signal may be improved still further by additional amplification and clipping. For this purpose, another diode and pentode might be added in cascade.

For 60-cycle operation, the following circuit constants are recommended: C_1 .5 μ fd., C_2 8 μ fds., C_3 4 μ fds., R_1 5,000 ohms, R_2 , 50,000 ohms, R_3 , R_4 , R_5 0.1 megohm. The plate voltage, E_B , must be 300 volts d. c. With appropriate changes in circuit constants, the basic circuit is operable at other input frequencies.

For 60-cycle operation, the sine-wave input signal voltage may be derived from the power line; or, more desirably, obtained from the secondary winding of a small transformer operated from the line or from the tube-heater line. The input signal must be approximately 100 volts r. m.s. For this value, a 6.3-volt filament transformer may be operated "backward" from the heater line supplying the two tubes. For operation at sine waves of other frequencies, an external oscillator with high output voltage must be provided. Whenever the oscillator does not deliver sufficient voltage, an amplifier will be required to build its output to 100 volts.

"THE HELP SITUATION" by Lorian



Are you hungry for help? Are you desperately trying to find some means of turning out the huge volume of work in your shop?

Then increase the manPOWER of those men you already have in your shop by placing a complete set of Rider Manuals on every bench.

Rider Manuals provide "The Extra Hand" you need, supplying authoritative servicing data to speed up the location of defects in faulty radio receivers.

Volume XIV of these standard works is now in preparation and the date of its publication will be announced shortly. In the meantime be sure you are getting every available bit of the assistance offered by Rider Manuals—be sure you have all thirteen volumes.

—And while you're checking—check the list at the right. Here are other Rider Books that are being used for training in all branches of the Armed Service. They can speed your mission to "keep 'em playing" on the homefront.

HERE'S HELP
THAT YOU
Can GET

RIDER MANUALS (13 VOLUMES)

Volumes XIII to VII.....\$11.00 each volume
Volumes VI to III..... 8.25 each volume
Abridged Manuals I to V [1 volume]....\$12.50
Automatic Record Changers and Recorders 6.00

OTHER RIDER BOOKS YOU NEED

The Cathode Ray Tube at Work
Accepted authority on subject.....\$3.00
Frequency Modulation
Gives principles of FM radio..... 1.50
Servicing by Signal Tracing
Basic Method of radio servicing..... 3.00
The Meter at Work
An elementary text on meters..... 1.50
The Oscillator at Work
How to use, test and repair..... 2.00
Vacuum Tube Voltmeters
Both theory and practice..... 2.00
Automatic Frequency Control Systems
—also automatic tuning systems..... 1.25
A-C Calculation Charts
Two to five times as fast as slide rule..... 7.50
Hour-A-Day-with-Rider Series—
On "Alternating Currents in Radio Receivers"—
On "Resonance & Alignment"—
On "Automatic Volume Control"—
On "D-C Voltage Distribution".....90c each

JOHN F. RIDER PUBLISHER, INC.

404 Fourth Avenue, New York 16, N. Y.
Export Division: Rocke-International Electric Corp.
13 E. 40th Street, New York City Cable: ARLAB

RIDER MANUALS
GIVE YOU THE HELP YOU NEED!



4 NEW *Fact-Ful* GUIDES FOR DESIGNERS OF COMMUNICATIONS EQUIPMENT



D-C CAPACITORS—Lists and describes a complete range of capacitors for d-c applications from 400 to 250,000 volts. Booklet 3300.

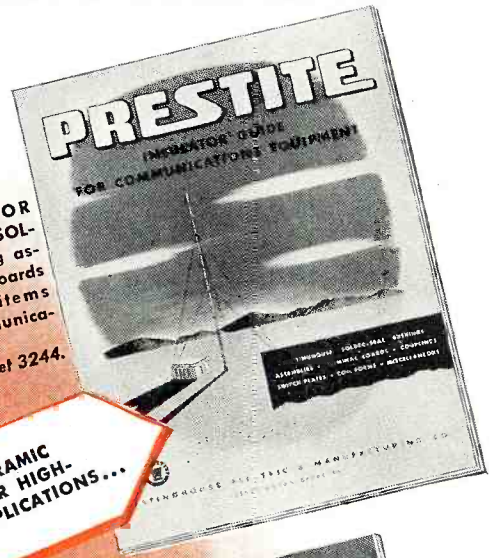

PRESTITE INSULATOR GUIDE—Blueprints of SOLDER-SEALED bushing assemblies, terminal boards and many other items available for communications equipment. Booklet 3244.

HIGH VOLTAGE D-C CAPACITORS . . .

SOLDER-SEAL CERAMIC INSULATORS FOR HIGH-FREQUENCY APPLICATIONS . . .



FASTER HF COIL ASSEMBLIES . . .

PREASSEMBLED HIPERSIL CORES—Lists sizes and applications of new 2-piece, thin-lamination cores for High-Frequency equipment. Booklet 3223-A.

STEPPED-UP D-C VOLTAGES . . .

WESTINGHOUSE DYNAMOTORS—A full description and listing of dynamotors available for aviation and communications equipment. Booklet 3242.



SEND FOR THESE NEW BOOKLETS TODAY!

Whether it's a problem of stepping up d-c power . . . reducing core assembly time . . . locating the right high-frequency insulators or high-voltage d-c capacitors in a hurry, you'll find the answer in these new Westinghouse publications. Complete listings of sizes, weights and dimensions, together with application guides make these booklets an invaluable aid in designing and ordering.

These are only four examples of the help that Westinghouse can offer in the design and manufacture of communications equipment.

Other helpful publications are available on

- Micarta insulating parts and materials
- Thermostats
- Instruments
- Rectox rectifiers
- Relays
- Contactors

Whatever your problem, Westinghouse Communications Equipment and Communications Specialists can help you find a quick solution. Call on Westinghouse for help. Ask for the booklets you want from your Westinghouse representative, or write Westinghouse Electric & Mfg. Co., East Pittsburgh, Pa., Dept. 7-N. J-94613



Westinghouse
PLANTS IN 25 CITIES . . . OFFICES EVERYWHERE

Communications Products

When only bare essentials are available, the fundamental circuit of Fig. 4 may be employed without refinements. V_1 will be any small diode, such as type 6H6 or 1-V, and V_2 will be a 6SJ7, or other pentode with similar sharp cut-off characteristic. It is strongly urged, however, that whenever possible, the square-wave generator be assembled as a complete, self-contained and self-powered unit with the circuit additions which will be outlined presently.

Electrical Features

The complete circuit diagram of the simple square-wave generator is given in Fig. 1. The instrument embraces a triode preamplifier, diode-signal rectifier, pentode-clipper tube, and self-contained power supply.

The preamplifier stage, comprising input capacitor C_1 , gain control R_1 , triode V_1 , and selector switch S_1 , serves to boost the sine-wave input signal. Maximum gain in this stage will be approximately 20, and is boosted further by the 2-to-1-ratio interstage transformer, T_{1a} . When the selector switch, S_1 , is thrown to the right-hand position, a 60-cycle sine-wave signal is picked off the tube-heater circuit. One side of the heater line is grounded and the high side is connected through the switch to the grid-coupling capacitor. When the selector switch is in the left-hand position, the input circuit of the amplifier is connected to the terminals T_1

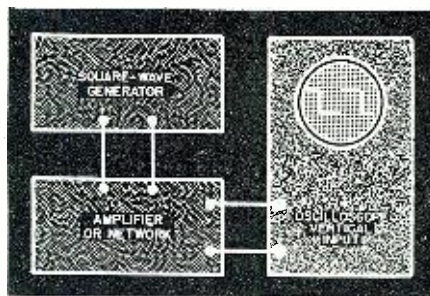

Fig. 3. Operating setup.

and T_2 , to which an external oscillator is connected when square waves of some frequency other than 60 cycles are required.

V_2 is a half-wave signal rectifier; a 6H6 tube with its elements connected in parallel. This stage is fed by the secondary voltage of T_{1a} , which should be approximately 100 volts r. m. s. for best results. By means of gain control R_1 , this voltage may be adjusted precisely to the best value. DC output-voltage pulses will be developed across the load resistor, R_2 , and applied directly to the grid of the 6SJ7 clipper tube V_3 , each time the lower end of T_{1a} secondary swings positive.

The cathode of the 6SJ7 is connected directly to ground, and accordingly is at zero bias in the no-signal state. The suppressor of this tube is likewise at ground potential, and the screen by-pass capacitor, C_3 ,

is returned to cathode by the shortest possible route. R_3 is the plate-load resistor for the clipper tube; R_4 , the screen series dropping resistor.

Square-wave output voltage is delivered through the coupling circuit comprising C_4 (4 microfarads) and R_5 (100,000 ohms). The latter, being variable, serves as an output-gain control. Square-wave output voltage is available at terminals T_3 and T_4 .

The self-contained miniature power supply embraces transformer T_5 , power-rectifier tube V_4 (a type 5W4), midget filter choke CH, dual-electrolytic capacitor C_5 - C_6 , voltage divider R_6 , and switches S_2 and S_3 . Capacitors C_7 and C_8 are essential for hum reduction when frequencies other than 60 cycles are fed into terminals T_1 and T_2 . Switch S_2 serves to interrupt the plate and screen voltages when it is desired to render the generator inoperative without interrupting the filament voltage. For safety, this switch is included in the negative, rather than the B-plus lead.

The taps are arranged on the voltage divider in such a manner that 250 volts are delivered to the 6C5 plate circuit and 300 to the 6SJ7 high-potential line. These taps are adjusted with the tubes lighted but with zero signal input. Plate and screen potentials will then be set for full-load no-signal conditions. In some cases, where individual layouts demand, it may be necessary to connect 8- μ fd. electrolytic "buffer" capacitors between the two high-voltage taps and ground.

Some improvement in stability of operation might be expected by providing VR-type voltage regulator tubes to control the 250- and 300-volt values. However, the author's tests did not indicate that the additional expense and chassis space justified the addition.

The entire unit is powered by the 115-volt line. This arrangement will be most desirable in usual applications. However, should individual requirements demand complete isolation of the instrument from the power line, battery operation is entirely permissible. The tube line-up for battery operation would comprise (V_1) 1G4-G, (V_2) 1G4-G with plate and grid tied together at socket, and (V_3) 1D5-GP. All tubes must be externally shielded, and the resistor and capacitor values will need to be altered somewhat according to the rules for applying those tubes to amplifier circuits. Switch S_1 would be eliminated, since both 60-cycle and high-frequency sine-wave voltages would be supplied from an external source through terminals T_1 and T_2 .

In the a. c.-operated version, illustrated in Fig. 1, all tube shells must be grounded by shortest connection of the No. 1 socket pin to chassis. It is desirable, although not imperative, that capacitors C_1 , C_2 , and C_3 be metal-encased for good shielding. C_4 must be a good-grade elect. condenser, with highest insulation resistance, and



Still your best bet for replacements

Centralab
VOLUME CONTROLS

*Old Man Centralab

"Old Man" is right
... for he is a real
"old timer". There
is no substitute for
experience, and
the "Old Man"
now, as in the past
twenty-two years,
is still your best bet.

Centralab

Division of GLOBE-UNION INC., Milwaukee



Veteran in Search of a Peacetime Future

THIS veteran knows of no job to come back to after the war.

It was born of war necessity—built to perform a strategic purpose new in the history of aircraft.

The requirements were an engineering challenge. It had to be strong to do its heavy work. Yet it had to be light and fit in the small space available.

That is why even optimists doubted such a device could be built.

But here it is: The Lear Actuator.

Its job is operating flaps, landing gears, shutters and other equipment on the power of an airplane storage battery.

Now, of course, our plants are working round the clock to make enough of these for the fighting ships of Uncle Sam.

But we know that such unique devices, the midget motors that drive them and all the 250 Lear products, must have an important future in some peacetime products.

They may park your car with the push of a button—or do any of thousands of jobs we haven't thought of.

That is why we are telling you about them. We want to find jobs for these able veterans.

And we want you to know that the kind of engineering thinking and production technique that made them possible is available.

PLANTS: Piqua, O., and Grand Rapids, Mich. BRANCHES AT: New York, Los Angeles, Chicago, Detroit, Cleveland, Providence.

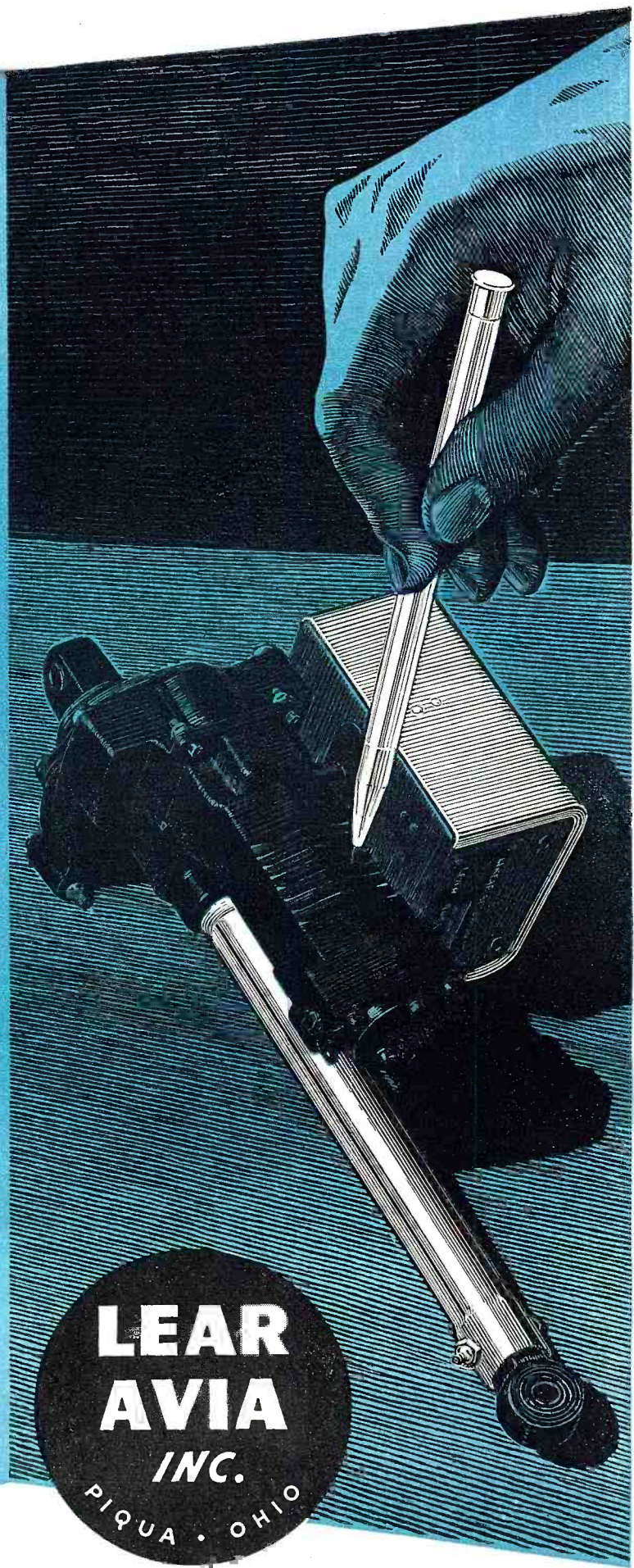

**LEAR
AVIA
INC.**
PIQUA • OHIO

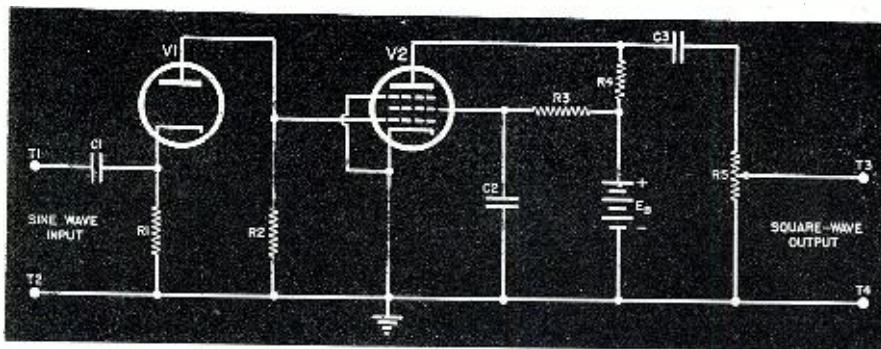

Fig. 4. Circuit diagram of the basic design of the square-wave generator.

must be either wax- or oil-impregnated. For good shielding, the back plates of the potentiometers, R_1 and R_2 , must be grounded to chassis by the shortest and most direct route to chassis. While it is desirable that the interstage transformer, T_{1a} , be completely encased, this will not be necessary if reasonable care is taken in its mounting to keep it out of the field of the power transformer and filter choke.

AC-DC operation of the square-wave generator is not recommended for reasons of safety from electric shock and also because of high potentials which might be encountered when operating the instrument from sine-wave oscillators or into amplifiers which are likewise a.c.-d.c. This applies to voltage-doubler operation as well as to regular half-wave line rectifiers. However, if an available power transformer does not possess

a 6.3-volt winding, the heaters of the three "active" tubes (V_1 , V_2 , and V_3) may be operated in series from the power line through a 320-ohm, 50-watt resistor, or similar Cordohm.

Mechanical Features

The chassis layout for the square-wave generator is shown in Fig. 5 and in the photograph. The placement of parts will be clear from these two illustrations.

The instrument is mounted on a 7" x 7" x 2" metal chassis, and might be enclosed within a 7" x 7" x 7" metal case. The active tubes are mounted in line along the front of the chassis, with the 6C5 at the right. Interstage transformer, T_{1a} , Choke CH, electrolytic filter capacitor C_5 - C_{10} , and voltage divider resistor R_5 are mounted below chassis, as indicated by the dotted lines. Small tubular electrolytic units are chosen for C_2 and C_3 in

order to permit easy mounting in the crowded under-chassis quarters. The interstage transformer is slung between the 6C5 and 6H6.

The power transformer is mounted in the extreme upper left-hand corner and the 5W4 rectifier tube stands close by. The μ fd. can-type oil-filled capacitor, C_6 , stands upon the chassis between the 6SJ7 tube and the power transformer. This unit is mounted through a 1-inch-diameter hole.

The three switches and two potentiometers are mounted along the front edge of the chassis, arranged in the following order from left to right: S_3 , R_1 , S_2 , R_3 , and S_1 . Terminals T_1 and T_2 are binding posts mounted on the right-hand edge of the chassis; T_3 and T_4 , on the left-hand edge. T_2 and T_4 , being grounded, pass directly through small holes in the chassis and make contact with the latter. T_1 and T_3 , on the other hand, are at high potential and must be insulated. These two binding-post terminals accordingly are insulated from the chassis by shoulder washers of bakelite or fiber, through which their contact screws pass. The power-line cord enters the chassis through a rubber-grommeted hole directly to the rear of the power transformer and drilled in the back edge of the chassis.

All connections must be as short and direct as possible. It is recommended that rigid hookup be employed throughout. The tube heater line is composed of twisted hookup wire pressed close to chassis. The various resistors are run directly between tube socket terminals whenever possible, and are supported by insulated terminal strips in all other cases. Leads from T_1 to S_1 , from S_1 to C_1 , from C_1 to R_1 , from R_1 to the 6C5 grid, from C_2 to R_2 , and from R_2 to T_3 are enclosed in a good-grade shield braid connected to chassis at each end of its length.

As much of the wiring as possible should be cabled neatly. All of the high-voltage leads are included in the desirable group for cabling. Cabled leads, as well as those which are shielded or twisted, should be held to the chassis by small clamps which may be improvised from soldering lugs. This practice imparts rigidity to the wiring construction and insures circuit stability.

If the fields of the power transformer, interstage transformer, and filter choke overlap, it will be necessary to rotate the position of one or more of these components in order to eliminate hum pickup. With the layout shown, little difficulty should be experienced from this source if the recommended components are employed. However, when using other equivalents, lack of shielding and other points of design might introduce hum fields.

At the frequencies which normally will be employed in operating this instrument, stray capacitances will not cause mischief. Due to the rather compact layout, the active leads will

-no matter how *Deft* your touch-

De Luxe SPEED KEY
 Model CP-800
 For Rhythmical Morse Sending

Professionals and amateurs alike know the uniform performance and accurate response of this T-A-C Bug. All T-A-C instruments reflect the very finest in precision-built radio telegraph apparatus and the skill of mechanical craftsmen. Telegraph Apparatus Co. products meet the exacting specifications of all operators in their requirements for communications apparatus.

TELEGRAPH

APPARATUS CO. NOT INC.



325 WEST HURON STREET • CHICAGO 10 • ILLINOIS



Two Suggestions

... On How To Replace Bias Type Volume Controls with the 10,000 Ohm Linear Units

The bias type of volume control circuit makes use of a variation of bias voltage applied to the tubes to control the volume of the receiver. Several forms have been used, such as grid return to the negative "B" potential, cathode connection to voltage divider tap, etc. However, the most popular was the simple variable resistor usually connected in the cathode return of RF stage or stages. The "Original Circuit" illustrates this system.

Here are two suggestions for using a 10,000 ohm linear control, either carbon or wire wound type, for applications using resistance values of 2,000 to 20,000 ohms in the bias control system. Care should be exercised with installation of the carbon type in cases where two or more stages are controlled through the unit, or where a considerable bleed current is employed.

The possibilities of wartime substitution are many. For special assistance on problems of this kind, write the Mallory Technical Information Service. We'll be glad to help.



Buy More War Bonds

P. R. MALLORY & CO., Inc., INDIANAPOLIS 6, INDIANA

P. R. MALLORY & CO. Inc.

MALLORY

Approved Precision Products

Original Circuit

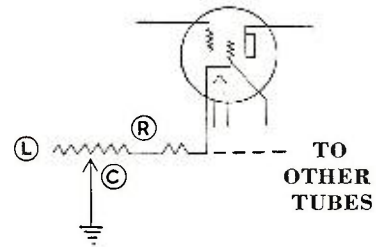

Original Control has a resistance of 2,000 to 20,000 ohms: usually a right-hand taper, although a few are linear.

Replacement Suggestion No. 1

(Where Original Control Has a Value of 10,000 Ohms or Less)

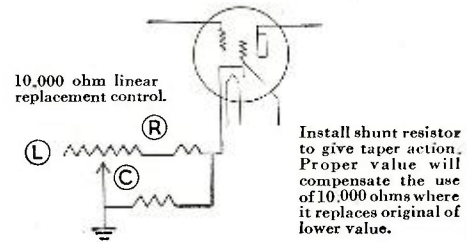

Replacement Suggestion No. 2

(Where Original Control Has a Value of More than 10,000 Ohms)

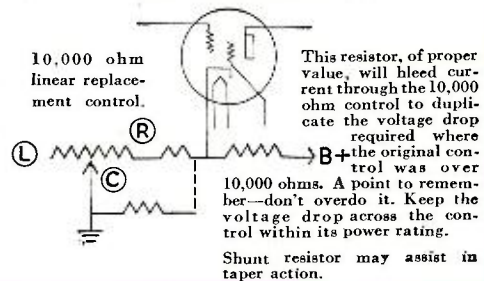

Mallory Helps for the Radio Service Engineer



MYE TECHNICAL MANUAL
—408 pages of complete data on capacitors, noise suppression, receiving tubes, loud speakers, vibrators, phono-radios, automatic tuning and other valuable information. Available from your Mallory distributor...Price, \$2.00.

4TH EDITION RADIO SERVICE ENCYCLOPEDIA... Complete information on repairing any make or model of receiver. Circuit references, original part numbers and recommended replacements. Available from your Mallory distributor... Price, 95 cents.

not be appreciably long and the small capacitances which might serve to bypass some of the very high-frequency components of the signal waveform will not be too much in evidence.

The bottom plate of the chassis is installed after assembly, wiring, and preliminary testing have been completed, in order to complete the shielding and to protect the below-chassis components from injury when the generator is placed upon the laboratory table. If a dust cover is used, it should be fastened to each edge of the chassis by not less than two screws per edge and must be provided with adequate ventilating holes or louvres.

Care should be taken to select for the R_1 and R_2 potentiometers ones which have "cold" shafts. Otherwise, it will be necessary to mount these units through fiber or bakelite shoulder washers in order that the line to T_3 and the one to the 6C5 grid may not be grounded to chassis.

Tube-heater wiring must be kept clear of the 6C5 and 6SJ7 grid leads and 6H6 plate and cathode leads. This applies likewise to the power-line cord which, though entering via the rear of the chassis, must traverse the entire width of the base to the on-off switch, S_2 , on the front edge. Throughout its length, this cord is held fast to the chassis by means of full-sized cable clamps, and is run closely along the chassis edges and near the chassis top. This line must preferably be insulated with live rubber, but in lieu of the recommended type of insulation which

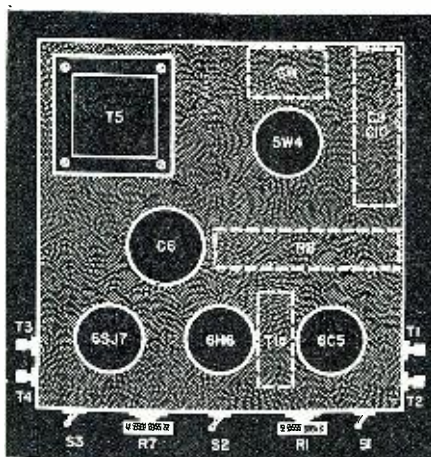

Fig. 5. Chassis assembly.

is daily growing more scarce in experimental circles, a good grade spaghetti may be employed.

In assembling the instrument, lock washers should be used liberally.

Since the square-wave generator is designed for operation expressly in the audio-frequency range, high-quality insulation is not a must in tube sockets. Inexpensive bakelite wafer sockets will be entirely adequate. Chassis material, likewise, is not critical. The chassis may be formed from any available metal, even from galvanized iron or tin-plate, by the energetic experimenter. The layout is sufficiently flexible to permit the use of chassis other than the size specified. In short, almost any available material might

be employed if sufficient allowance is made for stray capacitances when larger chassis, and accompanying longer leads, are employed.

Adjustment

The simple square-wave generator needs no complicated calibration. If the circuit schematic and layout have been followed, only a few initial adjustments and tests, which will now be outlined, need be made. It is suggested that the following order be followed:

1. With the power plug removed from the a. c. line, set R_1 and R_2 to zero, set S_1 to 60 cycles, open S_2 and S_3 , and move the two sliders on R_3 to the bottom of the resistor.

2. By means of insulated flexible leads, connect a high-resistance d. c. voltmeter between ground and the 300-volt slider on R_3 . Insert the a. c. power plug. Throw S_2 and allow a few minutes for the tube heaters to come up to operating temperature.

3. Throw S_3 and move the 300-volt slider slowly up R_3 until 300 volt indication is obtained on the voltmeter. Transfer the voltmeter positive lead to the 250-volt slider and move the latter slowly up R_3 until a 250-volt deflection is obtained. Because of plate current differences in the 6C5 and 6SJ7 tubes, it may be necessary to shift the positions of the two sliders somewhat with respect to each other before the exact voltage values are obtained. Remove voltmeter and tighten slider screws.

4. Connect the vertical input terminals of a cathode-ray oscilloscope to terminals T_3 and T_4 , and set R_1 at about half-scale. Set linear sweep of scope at 605 cycles. Bring R_2 up slowly, noting that a 60-cycle square wave appears on the screen. If the height of the pattern is insufficient, the setting of R_1 should be increased, and if the squareness of the waveform is not good, R_1 should be readjusted.

5. To utilize frequencies other than 60 cycles, throw S_1 to the EXT position and connect an audio oscillator capable of delivering the desired frequency to terminals T_1 and T_2 . This oscillator must be capable of supplying an output voltage of at least 10 volts. R_1 is then adjusted once more for good wave shape, and the height of the pattern may be controlled by adjustments of R_2 .

6. If at any time during tests it becomes desirable to interrupt the generator's operation without extinguishing the tube heaters, open the B-plus switch, S_3 .

7. When testing an amplifier or other a. f. network, the generator, operating in the manner described above, is set up for the desired frequency. Terminals T_3 and T_4 are then connected to the amplifier input (See Fig. 3) and the oscilloscope vertical-input terminals to the amplifier output. It is desirable to make observations on the amplifier at two frequencies, one low and one high. Generally, 60 and 2500 cycles will suffice.

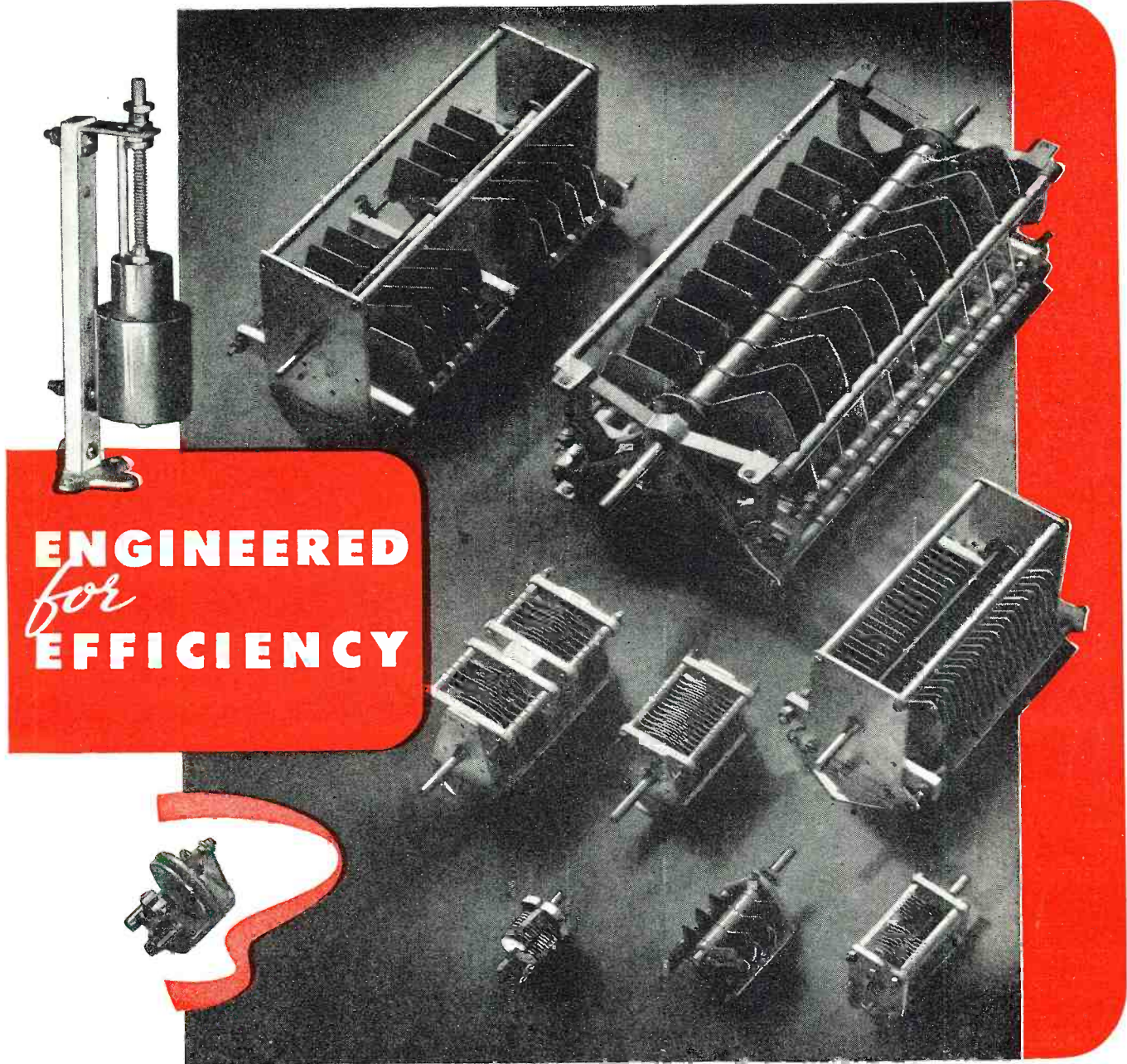

ENGINEERED
for
EFFICIENCY

From the little "J" to the big commercial type "A", from the neutralizer type "N" to the special temperature compensator type, all JOHNSON variable condensers are correctly designed and engineered for the part they must play in the transmitter circuit. Corona discharge, flash-over rating, galvanic and electrolytic action of metals, closed loop (losser) circuits within the condenser, and dozens of other problems enter

into the design of an efficient condenser. The metal and the alloy used, the shape and size of each part, the shape, size, and material of the insulators, all are highly important. Mechanically they are simple—electrically, an efficient condenser demands years of experience and "know how." Write us concerning YOUR condenser problems and JOHNSON will recommend a type for YOUR needs.

Ask for
CATALOG
967Z

JOHNSON
a famous name in Radio



E. F. JOHNSON COMPANY • WASECA • MINNESOTA

March, 1944

85

Aircraft Control Devices

(Continued from page 23)

the automatic transmission of traffic control instructions from ground personnel to pilots, voice as a communication medium could be entirely eliminated in the control of air traffic. This plan involves the storage of traffic clearance data on mechanized flight progress boards in airway traffic control centers and the automatic transmission of this data by radio at appropriate times to actuate a device in the aircraft which might be called a "traffic clearance indicator."

As visualized, the circumference of

the traffic clearance indicator (Fig. 7) would be taken up by a series of lamps, one for each flight level. As the plane proceeds at an altitude for which clearance has already been received, the lamp for that level remains lighted. When a clearance to another altitude is received, the lamp for that altitude starts to flash and the lamp in the center, over the word "change," lights to attract the pilot's attention to the fact that new instructions have been received. This light is extinguished by the pilot when he pushes the "acknowledge" button, causing at the same time the transmission of his aircraft identification and the clearance as it appears on his instrument. This acknowledgment is automatically com-

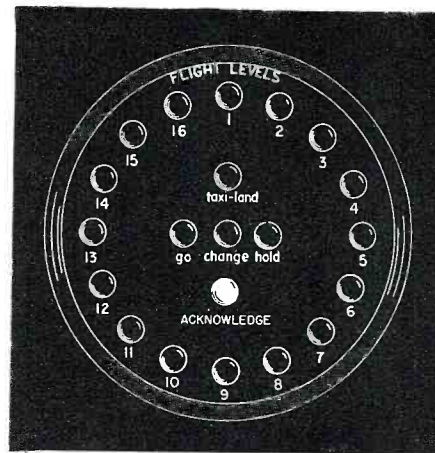

Fig. 7. Traffic clearance indicator.

OPPORTUNITY

for men with a knowledge of

**COMMUNICATIONS
EQUIPMENT**

★ Help your country and yourself. A war plant making vital equipment for the Army, Navy, Air Force, and Coast Guard is in urgent need of personnel with knowledge of communications equipment to become:

ELECTRICAL INSPECTORS
MECHANICAL INSPECTORS
INSTALLATION SUPERVISORS
JUNIOR ENGINEERS
LABORATORY ASSISTANTS
DRAFTSMEN

JOBS EVERYWHERE — some at factory; others at military and naval centers throughout country. Plant is located in the Chicago area. Modern equipment, excellent working conditions, old established firm, promising future after war.

FREE TRAINING: Experts teach you quickly at no cost. Earn while you learn.

WRITE FOR DETAILS: Will be sent on receipt of your letter stating experience, education, age, references, draft status.

Do Not Apply if 100% in War Work!

Our entire personnel knows of this advertisement

WRITE BOX 331 C/O RADIO NEWS
540 N. Michigan, Chicago

pared at the control center with the posted clearance and a disagreement warning appears before controlling personnel if an error is apparent.

The indicators shown in the center of the dial include "go," "hold," "change" and "taxi-land." The "taxi-land" light is used for airport traffic control when the aircraft is to move on the ground or to authorize a landing. "Go" authorizes a take-off or forward progress at the indicated altitude. "Hold" calls for remaining stationary while on the airport and for maintaining the indicated altitude at the next fix while enroute.

It should be understood that transmissions will be made and a pilot's indicator changed only when the pilot must make a change in the procedure he has been following. In many cases only a brief transmission upon departure will be required plus one or more in connection with landing at destination.

Block Signal System

In the much more distant future it may be found necessary to combine the traffic clearance indicator and the automatic aircraft position reporter into an automatic "block signal system" of a type similar to that used by the railroads. This system, as visualized at this time, would consist of marker transmitters producing a screen across the airways at block signal "fixes" 10 to 15 miles apart. An aircraft proceeding along an airway so equipped would set up a "hold" signal for succeeding aircraft at the same level which would not be cancelled until the preceding aircraft had climbed or descended to the next level or had passed the next block signal fix along the route. Thus, the block signal system would provide a warning to prevent two aircraft from being in the same "block"—the airspace between two adjacent fixes—at the same altitude. (Fig. 6.)

Future Ground Facilities for Air Traffic Control

In planning for additional ground facilities required to control air traffic of the future, the nature of such facilities will largely be dependent upon the

When

Clarion

Goes All-Out for Peace-Time Sales

DISTRIBUTORS:

CLARION Is Ready to Discuss Sales Plans With You!

A sales policy that will give every distributor and dealer a real opportunity for profit.

Advertising and sales promotion plans that will build leadership, with products that will hold such leadership.

... you'll see as fine and complete a line of radios as skilled designers and engineers can produce; a line that will offer true values, distinctive styles in a range of prices, and great performance.

Prepare now to tap the rich market that awaits the day when sets are again available. Plan with CLARION for your part of the tremendous demand that is bound to follow the war.

The Warwick Manufacturing Corporation, with manufacturing achievements and a financial stability that give it a high place in the radio world, is completing its distributor and dealer organization.

Our highly skilled engineering staff has been performing splendidly for the Government and the Armed Forces. The same ability will be applied to the production of equipment for a public that is hungry for radios.

You'll want to see the CLARION line. You'll be proud to handle it. It will pay you to begin preparations now for a CLARION franchise. Our Sales Department will provide you with plans that will prove profitable, and our advertising and sales promotion will build a leadership from which you can profit handsomely.

Use the coupon below in requesting further information and our GET ACQUAINTED BROCHURE.

F. M. . . . Television . . . Electronics

WARWICK MANUFACTURING CORPORATION
CHICAGO 44, ILL.



March, 1944

Warwick Manufacturing Corporation
 4640 West Harrison St., Chicago 44, Ill.
 Please send information and your Get Acquainted Brochure.
 Name of Firm.....
 Street Address.....
 City..... State.....
TODAY IS NONE TOO SOON TO BE THINKING ABOUT YOUR POST-WAR PLANS

accepted aircraft equipment. If the automatic air traffic control devices just described are adopted, then corresponding ground facilities also must be provided.

It has been estimated that approximately 850 air stations will be required within the next few years to provide an adequate schedule air carrier traffic pattern. This is over 3 times the present number of scheduled air carrier stops. Such a service pattern undoubtedly would require that air traffic control protection be afforded over all air space within the continental United States. It is not believed that the extension of air traffic control to include all air space will mean the discontinuance of civil airways. Rather, it is expected that civil airways will be continued as channels where a continuous heavy flow of traffic ordinarily exists. Flight outside of these channels will follow individual routes, but, nevertheless, will be afforded air traffic control protection to the same extent as is provided on the civil airways.

Basically, it is expected that the radio ranges, or comparable directional facilities, will delineate the civil airways system. Flight off the civil airways probably will be accomplished largely by use of automatic direction finding facilities.

With the establishment of automatic air traffic control devices in aircraft and with the provision of corresponding ground facilities, there appears to be but one remaining need of air traffic control which will require



Fig. 8. Scanning screens installed in airport traffic control towers.

additional ground facilities. This is the constant portrayal of actual positions of aircraft to controlling personnel.

By the installation of "scanning screens" in airport traffic control towers, it appears that this requirement can be met. One screen would portray the positions of aircraft in a horizontal plane within perhaps 25 miles of the airport. The aircraft positions would be indicated by a spot of light which would be constantly moving as the aircraft positions change. Another screen would show the relationship of aircraft in a vertical plane along the path followed by aircraft when approaching the airport under instrument weather conditions. A dot appearing on this screen would indicate the altitude of the aircraft and its position in the holding flight path.

The first objective on which the planning of future automatic air traffic control devices must be based is the requirement of *safety*. Safety, however, is relative—the degree of safety may be increased or decreased. Peacetime air transportation demands that the highest possible degree of safety be provided at all times and that every effort be exerted to reach this objective.

Absolute safety in connection with air traffic control would require the provision of means whereby circumstances would never arise in which two aircraft could possibly collide. Under such a condition controlling personnel could never make a mistake in judgment, flying personnel could never operate their aircraft other than in strict accordance with traffic control requirements, and all equipment and facilities on which traffic control was dependent could never fail. Obviously, absolute safety is an impossibility, and the actual degree of safety attained can only approach this ideal.

Efficiency as an objective in the control of air traffic means permitting the flow of traffic with the desired degree of safety but with minimum restriction or delay as a result of providing safety. Thus, an efficient air traffic control system will mean infrequent and little delay to the flow of air traffic and an inefficient air traffic control system will mean frequent delays.

If the development of air transportation, both commercial and non-commercial, is to be fostered to the fullest extent control of air traffic must be *simplified* as much as possible. Operation and use of automatic air traffic control devices must, therefore, be designed with this objective in view.

Even though the objectives of safety, efficiency and simplicity are attained in the desired degree, the air traffic control system will not be fully acceptable unless the objective of *economy* also is realized. Economy especially must be provided in connection with cost and weight of aircraft equipment required for air traffic control. Devices for installation in aircraft which might satisfactorily provide safety and efficiency in the control of air traffic would certainly not be economically acceptable if the cost and weight were out of proportion to the cost and pay load of the aircraft in which such devices would be installed.

Products of "MERIT" means Fine Radio Parts

... PARTS manufactured exactly to the most precise specifications.

Long manufacturers of component radio parts, MERIT entered the war program as a complete, co-ordinated manufacturing unit of skilled radio engineers, experienced precision workmen and skilled operators with the most modern equipment.

MERIT quickly established its ability to understand difficult requirements, quote intelligently and produce in quantity to the most exacting specifications.

Transformers—Coils—Reactors—Electrical Windings of All Types for the Radio and Radar Trade and other Electronic Applications.



MERIT COIL & TRANSFORMER CORP.
311 North Desplains St. CHICAGO 6, ILL.

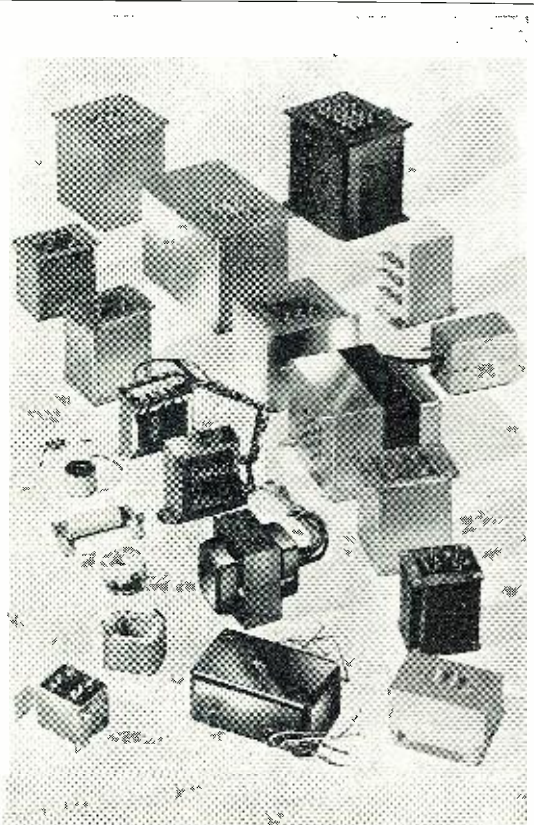

WHAT'S COOKING FOR POST-WAR?

More small tubes... lighter rigs... the kind Amateurs did so much to develop

SEEMS like more light, compact, inexpensive radio equipment than ever will be graduating from designers' drawing boards, come Victory.

So the ham, the experimenter, and the portable-packin' public—maybe the light plane radio buyer, too—can look for a trend, post-war, that the ham and experimenter did plenty to get started 'way back when.'

RCA's Miniatures made history

Keep your eye on RCA when the fun starts! Remember, it was RCA that developed those original 4 Miniature tubes—1R5, 1S4, 1S5, and 1T4—that made portable history with the "Personal Radio" announced by RCA in 1940.

And if you don't think Miniatures have been

places since, just ask the next paratrooper you meet about his "Handie-Talkie"!

On the Army/Navy's list

Did you know that 13 out of 15 of the Miniatures & Midgets on the Army/Navy "Preferred List of Vacuum Tubes" were developed by RCA?

You're probably pretty familiar with some of RCA's Miniature and Midget line of tubes, but you might like to look 'em over, all together. They're listed below, with some of their features.

Every month from now on, here on this page, we'll be trying to keep you posted on what's new in tubes — especially those for light, compact equipment.

RCA MINIATURE & MIDGET TUBES

Type No. and Name	Feature	Heater or Filament	
		Volts	Amperes
MINIATURES			
1A3 H-F DIODE (Heater Type)	For use as discriminator tube in FM receivers and in measuring equipment.	1.4	0.15
1L4 R-F AMPLIFIER PENTODE (Filament Type)	Has sharp cut-off characteristic—no external bulb shield needed.	1.4	0.05
1R5 PENTAGRID CONVERTER (Filament Type)	Has conversion transconductance of 300 micromhos at 90 volts on plate.	1.4	0.05
1S4 POWER AMPLIFIER PENTODE (Filament Type)	Capable of handling audio power output of 270 milliwatts.	1.4	0.1
1S5 DIODE-PENTODE (Filament Type)	Combines diode and a-f pentode providing high voltage gain.	1.4	0.05
1T4 SUPER-CONTROL R-F AMPLIFIER PENTODE (Filament Type)	Useful as r-f or i-f amplifier—no external bulb shield needed.	1.4	0.05
3A4 POWER AMPLIFIER PENTODE (Filament Type)	In r-f power applications, can deliver about 1.2 watts output at 10 megacycles.	2.8 series 1.4 parallel	0.1 0.2
3A5 H-F TWIN TRIODE (Filament Type)	Has class C output of about 2 watts at 40 megacycles.	2.8 series 1.4 parallel	0.11 0.22
3Q4 POWER AMPLIFIER PENTODE (Filament Type)	Can handle relatively high audio output of 270 milliwatts.	2.8 series 1.4 parallel	0.05 0.1
3S4 POWER AMPLIFIER PENTODE (Filament Type)	Similar to Type 1S4 but has center-tapped filament.	2.8 series 1.4 parallel	0.05 0.1
6AG5 R-F AMPLIFIER PENTODE (Heater Type)	Has sharp cut-off characteristic and high transconductance—useful up to about 400 megacycles.	6.3	0.3
6AK6 POWER AMPLIFIER PENTODE (Heater Type)	Can handle a-f power output of 1.1 watts.	6.3	0.15
6C4 H-F POWER TRIODE (Heater Type)	Has class C output of about 5.5 watts at moderate frequencies and 2.5 watts at 150 megacycles.	6.3	0.15
6J6 TWIN TRIODE (Heater Type)	Useful as mixer at frequencies up to 600 megacycles—also as oscillator.	6.3	0.45
MIDGETS			
9001 DETECTOR AMPLIFIER PENTODE (Heater Type)	For uhf service—has sharp cut-off characteristic.	6.3	0.15
9002 DETECTOR, AMPLIFIER, OSCILLATOR (Heater Type)	An uhf triode with moderately high amplification factor.	6.3	0.15
9003 SUPER-CONTROL R-F AMPLIFIER PENTODE (Heater Type)	Useful as mixer and as r-f or i-f amplifier in uhf applications.	6.3	0.15
9006 U-H-F DIODE (Heater Type)	Suitable for uhf use as rectifier, detector, or measuring device.	6.3	0.15



RADIO CORPORATION OF AMERICA

Camden, N. J.

RED HOT VALUES in RADIO PARTS!



Combination Table Cabinet

Modern table type phono cabinet, highly finished walnut. Dimensions: 14" front to back, 16" side to side, 5½" bottom of table panel to top, height over all, 13". In original cartons—while they last **\$7.95**

67½ V. B. BATTERY

4" L. x 1¼" D. x 2½" W. to replace Min. Max of same size. **\$1.85 each**



7½ V. C. BATTERY

4" W. x 2¾" H. x ¾" D.

39c each
10 for \$3.50



2 CELL 1½" V. A. BATTERY

Heavy Duty
3¾" H. x 1" D. x 1¾" W.

35c each. 10 for \$3.00



40,000 — New, First Quality Discs Recording Type — Paper Base



HIGH-QUALITY, double faced recording discs. Uniformly coated to mirror-smoothness. Non-inflammable. Made of durable paper-bond base. Low surface noise.

While They Last	Diam.	Quantity	Net
}	8"	10 in Pkge.	\$1.45
	10"	10 in Pkge.	1.75

SERVICEMEN'S SPECIAL!—10 lbs. Radio Parts Kit. Consists of all usable radio parts. . . . only \$2.95

FREE! Servicemen write today for free catalog listing thousands of parts bargains hardware and replacement parts.

**We Save You Money
Drop a Post Card Today**

10% Minimum Deposit Required with Order

RANDOLPH RADIO

609 WEST RANDOLPH ST., CHICAGO 6, ILL.

"Millions of Parts for Millions of Radios"

It would be highly desirable if the automatic air traffic control equipment for aircraft could be light enough and cheap enough so that all aircraft flying under instrument flight rules would be equipped with these devices. However, it is expected that at least for a long time only the larger aircraft will be so equipped. The most optimistic estimate would place not more than 50% of the aircraft flying in instrument weather by 1950 in the category of those having full automatic air traffic control equipment. This means that the air traffic control system would have to continue to be capable of controlling a substantial amount of air traffic involving aircraft having only the minimum air traffic control equipment such as is required at the present time.

However, the automatic devices for aircraft and the ground aids for air traffic control previously described point to the possibility of obtaining the ultimate objective of permitting the flow of air traffic under instrument weather conditions in the same volume and with the same frequency as is possible under contact weather conditions. This means that at an airport properly designed and adequately served by navigational air traffic control facilities, landings under instrument weather conditions would be possible at extremely short intervals. Thus, future planning seems to indicate that it will be possible for the air traffic control system within the United States to reach the level of safety and efficiency which ultimately will be required by mature air transportation.

—50—

Saga of Vacuum Tube

(Continued from page 52)

of the 102 series will be found in Figs. 94 to 97, inclusive.

The 102 type vacuum tube was an extremely long-lived device, because of the conservative engineering behind it and the low plate current required. The writer recently saw a 102A Repeater Bulb which had been removed from service in a laboratory device only two years ago. It had been in daily use for almost 20 years and was still functioning satisfactorily.

Another tube which was used in telephone equipment, but to a lesser extent than the "L" and "V" tubes, was the 104 type, which started life under the appellation of type "O". It was probably so designated because of its original use as an "output" tube. It had a lower plate impedance than either the "L" or "V" types. The "O" tube was first made commercially in the shops of the New York Engineering Department late in 1917. As originally made, it consisted of two plates ¾ inch wide and 1¼ inches high, spaced ⅛ inch apart, and two grids of the ladder type, the same size as the plates and spaced ⅛ inch apart. Each grid had nine laterals. The filament was M shaped. The structural difference between the

"L" and "O" tubes was chiefly in the spacing of the elements. The type "O" originally had two glass arbors, one for each plate-grid assembly. Late in 1918 the use of the second arbor was abandoned and the stem thus became similar to that of the type "L". The code designation "104A" was applied to this tube, which was later replaced by the "104D" Figs. 98 and 99 show some of the variants of these types.

All the Western Electric tubes thus far considered were engineered for use under the carefully controlled conditions existing in the telephone plant. But at the time of World War I the engineering skill and manufacturing experience which produced them were invaluable in providing background for the production of tubes for sorely needed military equipment.

Vacuum tubes for military and naval use are a "different breed of cat" from the telephone repeater. They must be capable of giving a reasonable service life under conditions which may vary widely at different times and in different places. In much equipment considerations of weight and space are paramount. Ambient temperatures vary from the cold of the radio cabin in the arctic to the broiling heat of a destroyer engine room in the tropics. Filament and plate voltages may vary widely and rapidly. Mechanical shocks are inevitable.

Nevertheless the Western Electric engineers, at the urgent request of the Armed Services, set about the development of vacuum tubes of stable and rugged construction to meet these new but no less exacting requirements. From their labors emerged a number of reliable tubes, probably the best known of which were the "VT1" and "VT2."

"VT1" was the U. S. Signal Corps designation for the tube, which in its inception was known to Western Electric engineers as the type "J". This same tube was also used by the U. S. Navy under the designation "CW933." The Western Electric code numbers assigned to this type were in the 203 series, the first being the 203A."

The "J" tube was a general purpose tube, being used as detector, amplifier, or low power oscillator. Fig. 100 is a photograph of one of the early "J" tubes. A cylindrical bulb was used instead of the spherical bulb common to the other Western Electric tubes up to that time. The element assembly used the same glass arbor construction as the telephone repeater tubes, and the earliest models had machined brass bases. The grids were of the ladder type and the plates were of flat sheet.

The glass arbor construction proved to be too fragile to withstand the severe vibration conditions imposed on the equipment in which the tube was used. In order to insure permanent alignment of the elements under the severest conditions there was developed a form of element assembly which became known as the "iron-clad" construction, in which the plate formed the support for the grid and

Now You can Use.

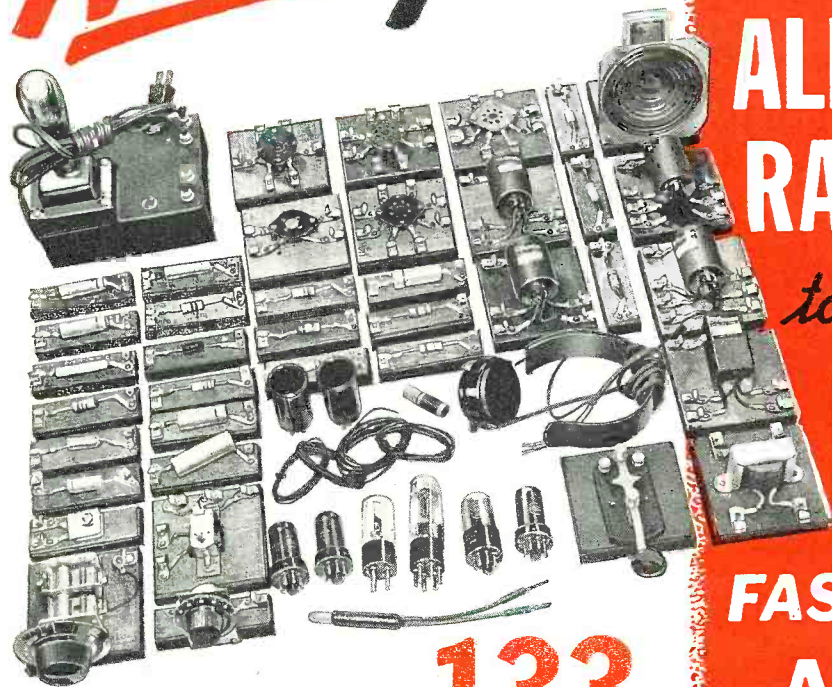

**ALL OF THESE
RADIO PARTS**

to help You learn

RADIO

**FASTER-EASIER
AT HOME**

**YOU CAN BUILD 133
FASCINATING EXPERIMENTS**

At home—in your spare time—you get real Radio experience with these many Radio parts and sub-assemblies. DeForest's handy "Block System" eliminates unnecessary mechanical work; the convenient clip connections save a great deal of time. Quickly build Radio circuits that work. Experiment with Photo-electric Cell "Magic," and scores of other fascinating projects. Little wonder learning Radio at home is so practical . . . so effective and so much fun—with this fascinating, DeForest's "Home Laboratory."

**YOU ALSO USE "LEARN-BY-SEEING"
MOVIES**

Think of the pleasure as well as the help you can get from the use of this genuine DEERY Motion Picture Projector and exciting Radio TRAINING FILMS. You'll likely be surprised how much faster . . . easier . . . home movies can help you understand Radio. Here's a preferred training method of tomorrow—yours today. SEE the principles of what you're learning—in action, ANIMATED! Peer into moving parts otherwise hidden from the eye. You get this big home-training, Radio advantage—exclusively with DEFOREST'S. So act now! Mail the coupon today!

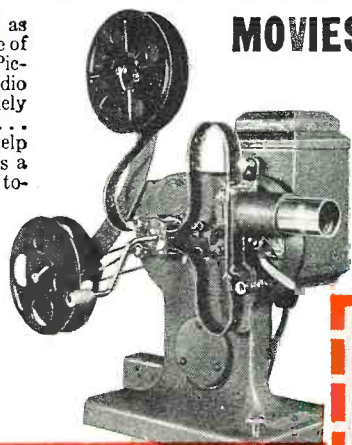

See how DeForest's fascinating SHOP-METHOD Radio Training at home can help you toward a good start in the Billion Dollar Radio Industry. Write for DeForest's BIG FREE book, "VICTORY FOR YOU," that has helped many to good-pay jobs in essential war industries; others to preferred Army and Navy classifications—and still others to interesting, profitable businesses of their own.

YOU GET "ALL THREE" WITH DEFOREST'S

Where else can you get such a combination of PROVED MAJOR Training features as—(1) ninety modern loose-leaf lessons prepared under the supervision of Dr. Lee DeForest, often called the "Father of Radio;" (2) the use of "learn by seeing" home movie films and a genuine 16 mm. DEERY MOVIE PROJECTOR—and (3) eight big kits of "home laboratory" Radio parts to give you thrilling practical Radio experience.

See how you can prepare for a bright postwar future now—in your spare time at home—then get started toward a worthwhile Radio-Electronics job with the help of DeForest's effective, proved EMPLOYMENT SERVICE. If you are 17 or over, mail the coupon today for complete details. You be the judge. No obligation.



**DEFOREST'S
TRAINING, INC.
CHICAGO, ILLINOIS**

DEFOREST'S TRAINING, INC.

2535-41 N. Ashland Ave., Dept. R-4, Chicago, U. S. A.

Please send me—FREE and WITHOUT OBLIGATION—illustrated book, "VICTORY FOR YOU," showing how I can prepare for Radio with your Home Movies and Laboratory Kits.

Name..... Age.....

Address.....

City..... State.....

filament. This structure was the result of an evolutionary process which can be traced through the steps shown in Figs. 101 to 104 inclusive.

The first change was in the base. The machined brass base was replaced by a lighter sheet metal base similar to that used in the standard telephone repeater tubes. The next construction was that shown in Fig. 101. Here the glass arbor has been eliminated and a new plate structure used. The plates are supported from the stem, and a stiffening rib provided. Ladder type grids with wire laterals are still used. Fig. 102 shows the next modification, which was the substitution of a corrugated plate for the flat plate in the preceding version. Fig. 103 shows a later modification, in which grids of punched sheet metal replaced those of the wire type. The final version, which was manufactured in large numbers as the VT1, is shown in Fig. 104. After the close of World War I many of these VT1s found their way into the general market, via sales of surplus Army equipment, and were used by amateur radio enthusiasts.

The VT1 operated with a filament current of 1.15 amperes at a voltage of 2 to 2.5 volts. The plate voltage used varied from 20 to 100 volts, and the plate current from 0.5 to 2 milliamperes, depending on the purpose for which the tube was used. The amplification factor was about 6 and the internal plate impedance 10,000 to 25,000 ohms.

The other widely known and used tube was the VT2. This was developed as a result of a request from the U. S. Signal Corps in 1917. The request was for a small transmitting tube to operate at a plate voltage of 300 volts. The VT2, which was also used by the U. S. Navy under the designation "CW931," was originally designated by Western Electric Company as the type "E", and later code numbers in the 205 series were assigned.

Fig. 105 shows one of the earlier "E" tubes. The construction was somewhat similar to the type "L" except that the plates had turned-up edges and different bracing wires. This difference in construction was necessitated by the higher plate dissipation of the "E" tube which tended to warp flat plates. The base first used was of the wax-filled type which was standard for use on telephone repeater tubes. This was later found unsatisfactory because of the higher temperature at which the "E" tubes operated, and was replaced by a base using a phenolic insert.

The VT2 operated with a filament current of 1.35 amperes at a voltage of 6 to 7.5 volts. The operating plate voltage was 250 to 350 volts, the plate current 30 to 45 milliamperes, amplification factor approximately 7 and internal plate impedance 3,000 to 4,500 ohms. It was rated at 5 watts continuous output as an oscillator.

Other uses were found for this series of tubes after the war, and the

manufacture of the 205B was continued until about 1924, when it was replaced by the 205D. The chief improvement was in the filament. The new filament was better electrically, and differed in appearance in that it was plain instead of being twisted. Since that time the "E" tube has undergone other changes which may be seen in Figs. 106 and 107.

There were, in addition to these tubes, several others made in somewhat smaller quantities for the U. S. Government during World War I. One of these bore the Western Electric code designation "201A," and was known to the Navy as the "CW186." This tube, with its three contact base, is shown in Fig. 108. It was similar to the type "V" except for the grid, which had 37 laterals on each side instead of 31. The 201A, as will be noted from Fig. 108, was made with a base which had three contact studs, the fourth terminal being the metal base shell. This was made in accordance with Navy requirements. This tube in the standard telephone repeater base had been known as the type "D" tube to the Western Electric engineers.

One of the difficulties encountered in the use of this tube by the Navy was microphonic trouble caused by imperfect contact between the metal base shell and its socket. To eliminate this condition the design was changed to use the four contact base, originally used on this type. In this form it was known as the Western Electric 201B, and is shown in Fig. 109. Few were made, however, since it was soon replaced in Navy equipment by the all-purpose "J" tube.

Early in 1918, at the request of the Signal Corps, the work of developing a tube similar to the VT1, except suitable for operation in portable equipment, was undertaken. The chief problem was that of obtaining a filament which would operate with a current of the order of 0.2 to 0.25 ampere from a single storage cell. The tube which fulfilled these requirements was designated "VT3" by the Signal Corps and was known to the Western Electric engineers as the type "P." Figs. 110, 111 and 112 show three of the structures used for this tube, that of Fig. 112 being the final one. The designation "VT-3" was etched on the bulb, in block letters, but the etching is too faint to show in the photograph. Only a few of these tubes were made since the necessity for them was reduced by the cessation of hostilities. The work was not lost, however, since the knowledge gained was used to good advantage in the development of the famous "peanut" tube, which will be discussed in our next article.

CAPTIONS FOR ILLUSTRATIONS

Fig. 92. Western Electric Type "V" Telephone Repeater Element, before basing. 1915. Photograph courtesy Bell Telephone Laboratories.

Fig. 93. Western Electric 102A Repeater Bulb. This is the first variant using the formed sheet metal base.

Quality TOOLS for

Quality WORKMANSHIP

XCELITE

← **Screwdrivers** **Nut Drivers** →

The original screwdrivers with the tough, transparent Xcelite shock-proof plastic handles. Blades of high quality steel, accurately machined. Unsurpassed tools for electrical and general use. Over 50 sizes and styles, square and round blades. Many sizes available with special fire-resistant handles at slightly higher prices.

Ideal tools for electrical work, especially panel jobs. Extra deep sockets, precision machined, handles two nuts. Handles are genuine shock-proof fire resistant Xcelite. Supplied in 6 inch and 9 inch lengths; 9 sizes from 3/8 inch to 1/2 inch nut size.

Xcelite Screwdrivers and Nut Drivers are available on satisfactory priority ratings. For details and prices on Xcelite Tools, ask your regular dealer—or write Dept. L.

PARK METALWARE CO., INC., ORCHARD PARK, N. Y.

Back the Attack — Buy More War Bonds

XCELITE **QUALITY TOOLS**
PREFERRED BY THE EXPERTS

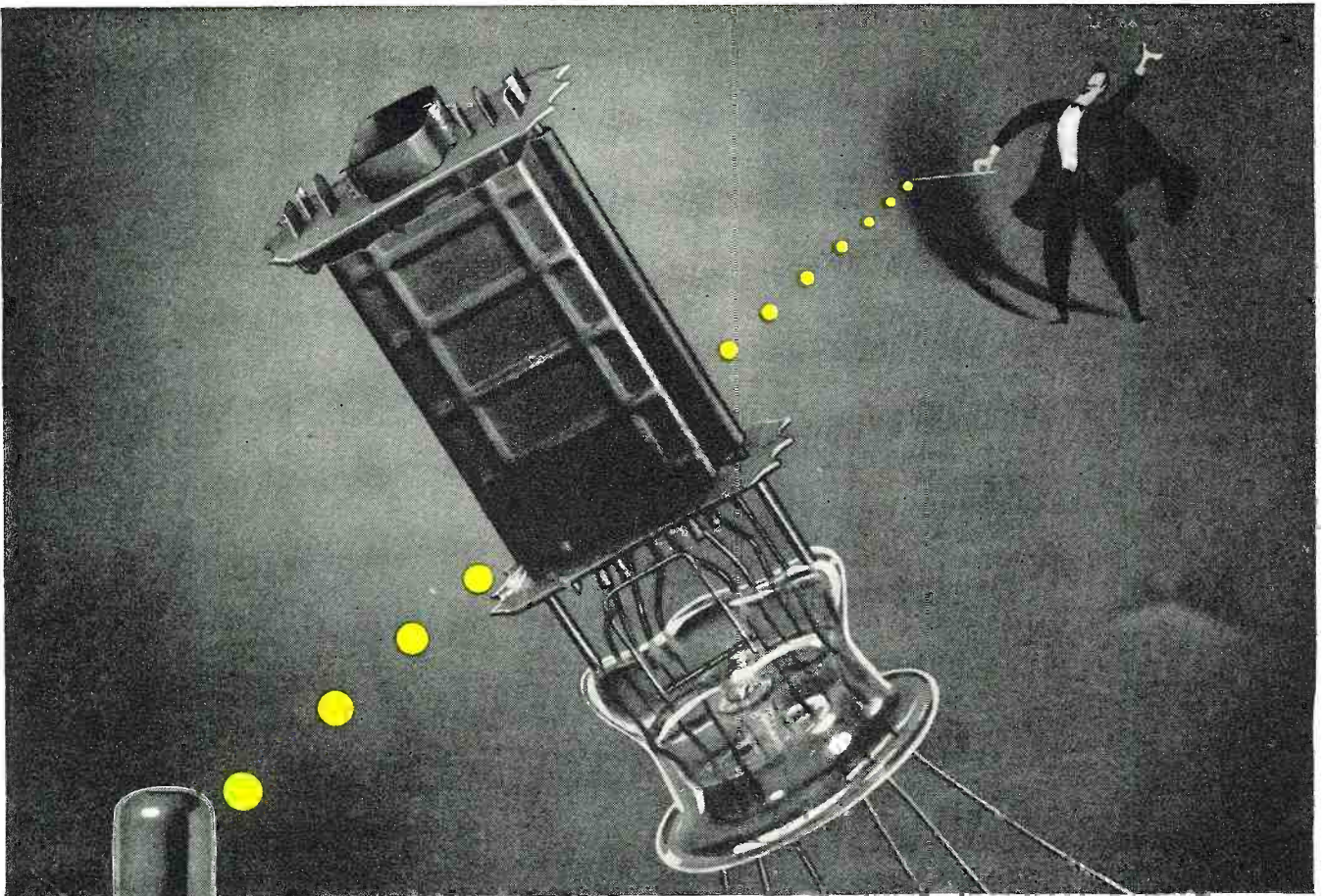

Metal Magic!



Long ago National Union engineers had to strike out for themselves in search of new metals, alloys and coatings. The extremely high temperatures employed in tube making—brazing, for example, at 2 to 5 times the heat customarily used—ruled out the use of metals common to most industries.

For this reason and for others peculiar to the needs of tube manufacture, there has come from the nation's electronic tube laboratories a whole new group of metals and combinations of metals. Here are special alloys for filaments, coils, grid wires, getters, electron guns and many

other uses. And as these metals have provided characteristics not previously available, they have literally pulled wonders out of the magic hat of electronics.

In metallurgy, as in other sciences related to tube making, National Union is helping to push back the frontiers of electronic knowledge. This research is helping, also, to provide for service engineers a broad, profitable post-war franchise. *Count on N. U. to be ready with better tubes for every important service need.*

NATIONAL UNION RADIO CORPORATION, NEWARK, N. J.
Factories: Newark and Maplewood, N. J., Lansdale and Robesonia, Pa.

NATIONAL UNION
RADIO AND ELECTRONIC TUBES

Transmitting, Cathode Ray, Receiving, Special Purpose Tubes • Condensers • Volume Controls • Photo Electric Cells • Panel Lamps • Flashlight Bulbs

THE MODEL 610-B

MEG-O-METER



A New Battery Operated INSULATION TESTER!!

Instantly measures the exact leakage of all insulation up to—

200 MEGOHMS

At a test potential of

500 VOLTS D. C.

Supplied by a built-in battery and vibrator power supply

SPECIFICATIONS:

*NO HAND CRANKING — The 500 VOLT POTENTIAL is made instantly available by simply throwing a front panel toggle switch.

*DIRECT READING—All calibrations printed in large, easy-to-read type enabling exact determination of leakages from 0 to 200 Megohms. In addition, the Megohm scale is also sub-divided into BAD (0 to 1 Megohm) DOUBTFUL (1 to 3 Megohms) GOOD (3 to 200 Megohms) sections. The BAD Section which indicates

Model 610-B comes housed in a beautiful, hand-rubbed Oak cabinet complete with cover, self-contained batteries, test leads and instructions. Size 9½" x 8½" x 6". Shipping weight 15 pounds. Price.....

the danger point is printed in red.
*3 RANGES: 0 - 20,000 Ohms, 0 - 2 Megohms and 0 - 200 Megohms.

*The instrument is housed in a heavy-duty Oak portable cabinet.

*Panel is of solid bakelite engraved by the new "cut-in" process which eliminates possibility of letters being scratched off.

*Meter movement—a 4½" 0 to 200 Microampere sensitive meter guarantees extremely accurate readings on all ranges.

\$62.50

SUPERIOR INSTRUMENTS COMPANY
Dept. R-N, 227 Fulton Street New York 7, New York

ILLINOIS CONDENSERS

.....WORTH REMEMBERING!

NEXT time you purchase capacitors let the satisfactory experiences of our many users be your guide—choose from the "ILLINI" line of electrolytic and paper types. They're known for reliability, durability and consistent quality. Manufactured by condenser specialists for eight years who produce nothing but condensers.



**ILLINOIS CONDENSER
COMPANY**

1160 NORTH HOWE STREET
CHICAGO, ILLINOIS

INCREASE YOUR EARNINGS WITH VAUGHAN'S MASTER BLANKS

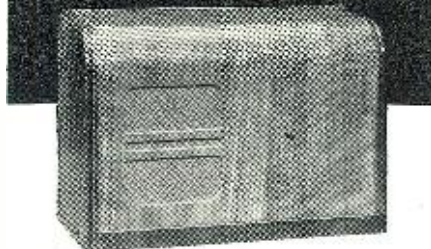

Cabinets as illustrated, speaker opening cut, opposite side blank.

These modernistic cabinets have been designed to fit every type chassis up to 10½" which covers practically all makes. Constructed from beautifully grained walnut, they are unusually attractive and striking in appearance. Easy to cut and fit they open up new opportunities to serve your customers as well as to reclaim many of the old unsaleable sets now in your store.

MODEL A Dealer's Price **\$2.10**
Inside Measurements 7¼L x 4¾D x 4¾H

MODEL B Dealer's Price **\$2.85**
Inside Measurements 8¾L x 5D x 5¾H

MODEL C Dealer's Price **\$3.00**
Inside Measurements 10¼L x 5½D x 6¾H

SAVE MONEY—10% discount in lots of six or more

SEND NO MONEY—We ship C.O.D. if desired

WE RESERVE THE RIGHT TO LIMIT QUANTITIES

VAUGHAN CABINET CO. 3810 N. CLARK ST. CHICAGO 13, ILL.

The code marking appears only in the wax filling of the base. Note colored lacquer—black—applied to tip.

Fig. 94. Western Electric 102D Vacuum Tube, showing Western Electric name, code, and patent marking on base in ⅛ inch characters.

Fig. 95. Western Electric 102D Vacuum Tube, showing Western Electric name, code, and patent marking on base in ⅜ inch characters.

Fig. 96. Western Electric 102F Vacuum Tube with code marking on base in depressed characters.

Fig. 97. Western Electric 102F Vacuum Tube of current construction. New element assembly and domed bulb.

Fig. 98. Western Electric Type "O" or 10½A Vacuum Tube—early construction.

Fig. 99. Western Electric 10½D Vacuum Tube—current construction. New element assembly and domed bulb.

Fig. 100. Early Western Electric Type "J" or 203A Vacuum Tube with machined brass base and glass arbor construction. Photograph courtesy Bell Telephone Laboratories.

Fig. 101. Western Electric 203A Vacuum Tube—third type—with element assembly supported by collar on stem of tube. Wire ladder type grid and flat plate with stiffening rib. Photograph courtesy Bell Telephone Laboratories.

Fig. 102. Western Electric 203A Vacuum Tube—later type with corrugated plate and wire grid. Photograph courtesy Bell Telephone Laboratories.

Fig. 103. Western Electric VT1 with early type punched grid. Photograph courtesy Bell Telephone Laboratories.

Fig. 104. Western Electric VT1—final version. Photograph courtesy Bell Telephone Laboratories.

Fig. 105. Early Western Electric Type "E" or 205A Vacuum Tube. Sheet metal base, wax filled. Photograph courtesy Bell Telephone Laboratories.

Fig. 106. Western Electric 205B Vacuum Tube—still later type with later patent markings.

Fig. 107. Early Western Electric 205D Vacuum Tube—with metal base and markings on bulb.

Fig. 108. Western Electric Type "D" or 201A Vacuum Tube. This was made for the U. S. Navy under the designation "CW186." Note the three contact base. Photograph courtesy Bell Telephone Laboratories.

Fig. 109. Western Electric 201B Vacuum Tube. Same as 201A shown in Figure 108 except for use of standard four-prong base.

Fig. 110. Western Electric Type "P" Vacuum Tube—first construction. Photograph courtesy Bell Telephone Laboratories.

Fig. 111. Western Electric Type "P" Vacuum Tube—second construction. Photograph courtesy Bell Telephone Laboratories.

Fig. 112. Western Electric VT3—final form of type "P" vacuum tube. The "VT-3" marking is etched on the bulb in block letters but the etching is too faint to show up in the photograph.

(To be continued)



There's new activity at Detrola Radio. Under the direction of Mr. C. Russell Feldmann—a radio-electronic pioneer who led the way in the development of the automobile radio—the Detrola plant and personnel have been completely reorganized. Large sums of money have been spent—for the installation of the most modern research, development and production facilities. Many new workers, including some of the best minds in radio engineering, now proudly wear the Detrola badge. All this plant and personnel are now engaged in supplying the armed forces with an ever increasing flow of precision-built equipment. That's our job today. All of it will be available for the production of ultra-modern, ultra-quality peacetime radio and other devices. That's our aim for tomorrow.

Detrola

goes forward

under New Direction



DETROLA RADIO

DIVISION OF INTERNATIONAL DETROLA CORPORATION • BEARD AT CHATFIELD, DETROIT 3, MICH.

C. RUSSELL FELDMANN • PRESIDENT

Spot News

(Continued from page 14)

thousand feet above an army air field in California this Cadet was stricken temporarily blind while at the controls of a one-man training plane. As the unguided plane sped through the skies, the panic stricken cadet shouted into his breast plate microphone: "I'm blind! I'm blind!" The message was heard by the control tower operator in charge who immediately dispatched instructions via radio. Every detail was radioed to Cadet Seale. He was told how to bank as he lost altitude. And when he approached the field, specific instructions were transmitted to him. Instructions that brought the plane to a perfect landing, thanks to radio. Fortunately, Cadet Seale's blindness was only temporary due perhaps to a nervous condition.

AN UNUSUAL CONSERVATION EXHIBITION in which radio played an important role was placed recently on display in the Social Security Building, Washington, D.C. The communications portion of the exhibit is divided into two parts; material and equipment.

In the component section of the exhibit appears a simplified panel meter that has replaced expensive and more critical meters in many applications. This meter contains no jewels, no moving coil and has a stamped out case and paper scale. The capacitors shown reveal how paper ceramics and lower grade mica have replaced critical higher grade mica. Lead wires, which in the past used pure tungsten, now according to the exhibit, use nickel alloy on 75 per cent of the rod. Copper has replaced tungsten 75 per cent in other lead wires. The use of plastics, instead of aluminum, also appears in this exhibit. Insulators made out of glass instead of steatite are also on exhibit. On output assemblies we find that copper has replaced 50 per cent tungsten. As a result, 90 per cent of the machining operations have been conserved. One of the biggest conservation items appeared to be name plates where plastics now replaces aluminum and glass. The exhibit also shows that wood has replaced plastics almost 100 per cent on instrument knobs. In the communications exhibit a chart comparing the quantity of strategic metals used in wire communications this year, with the amount used in 1941, is shown. A saving of critical metals ranging from 87 per cent to 98 per cent is indicated. One of the best indications of the conservation accomplished by the communications industry appears in the copper consumption figures. The reduction in copper consumption to about 5 per cent of its prewar average, emphasizes the conservation accomplished.

The exhibit includes material from the Army, Navy, Maritime Commission, aircraft industry, Joint Com-



CAPACITORS IN PLASTIC

American has pioneered in the application of plastics to electrolytic and by-pass capacitors. Engineered to precision standards in jar-proof design, with finer electrical characteristics. They improve the appearance of any radio or electronic assembly—and they boast a time-tested record for dependability.

DATA SHEETS ON REQUEST

AMERICAN CONDENSER CO.
2508 So. Michigan Ave. Chicago, Ill.

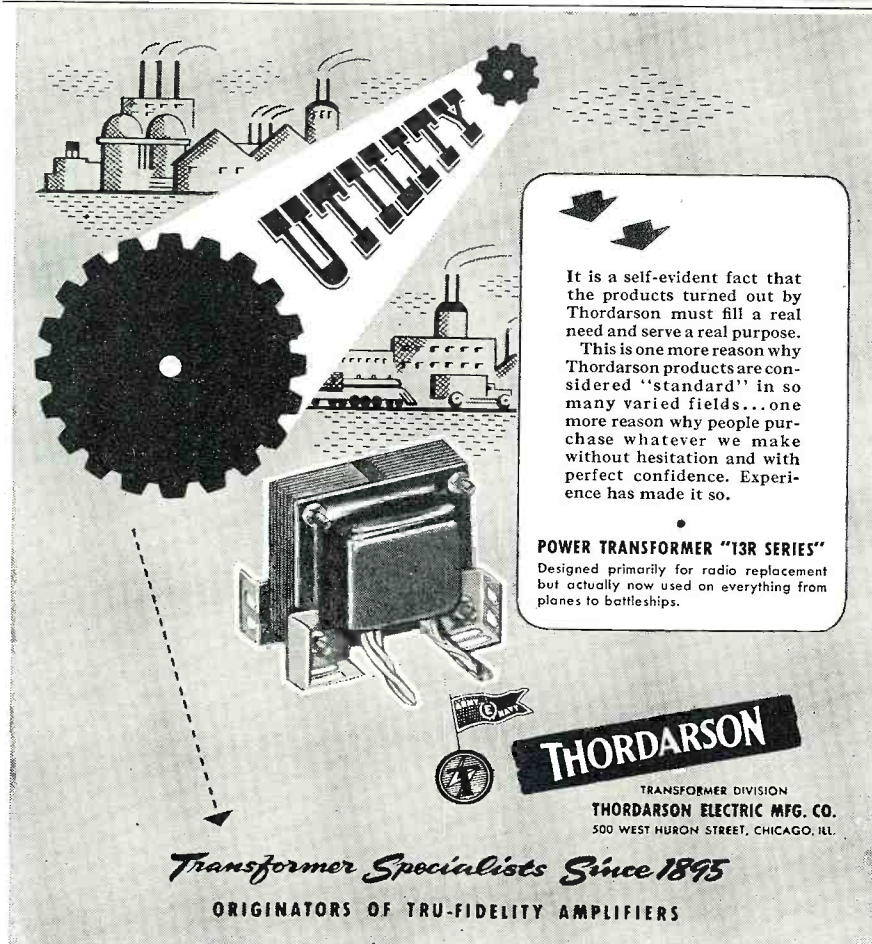

It is a self-evident fact that the products turned out by Thordarson must fill a real need and serve a real purpose. This is one more reason why Thordarson products are considered "standard" in so many varied fields... one more reason why people purchase whatever we make without hesitation and with perfect confidence. Experience has made it so.

POWER TRANSFORMER "13R SERIES"
Designed primarily for radio replacement but actually now used on everything from planes to battleships.

THORDARSON
TRANSFORMER DIVISION
THORDARSON ELECTRIC MFG. CO.
500 WEST HURON STREET, CHICAGO, ILL.

Transformer Specialists Since 1895
ORIGINATORS OF TRU-FIDELITY AMPLIFIERS

RADIO-ELECTRONICS

HOME-STUDY COURSE

IN 3 BIG MANUALS

8½ x 11 in.
50 LARGE LESSONS
New 1944 Edition



M. N. Bestman teacher and author of many books, directed this preparation. Instructions to help you study at home included in the narrow column on each page.



ONLY \$3.95 COMPLETE 3 VOLUMES 50 Lessons

GREATEST BARGAIN IN RADIO-ELECTRONIC TRAINING

Get a complete course of training in practical radio and electronics for less than the cost of a single book. The fifty large lessons, making up the complete course in 3 volumes, are simple to follow, easy to master and apply. Many drawings, examples, diagrams, and instructor's suggestions (in the side column, on each page) help you move along quickly and find learning interesting fun. Review questions at the end of each lesson permit you to check your progress. You enjoy learning important radio and electronic facts. In a surprisingly short time, you are ready to do highly skilled radio repairing, building of electronic equipment, or hundreds of other War-winning tasks in the growing Electronic and Radio industries

MANY LESSONS ON RADIO REPAIRING

Volume 3, of the course, includes lessons, service hints, case histories, and troubleshooting charts which will show you how to repair all radio sets quickly and easily. This material alone is worth many times the low price of \$3.95 for the complete 3-Volume course. Send *no-risk* order coupon today. Look over and use these lessons for 10 days without obligation. You have everything to gain—and nothing to lose.

These Lessons Will Tell You All About

Meters, Power Supplies
Circuits, Microphones
Test Equipment, FM, Tubes
Oscillators, Amplifiers
Photo-cells, Circuits, X-ray
Facsimile, Television
Recording, Superhets
Alignment, Motor Control
Radio Servicing, Gages
Electronics in Industry
Radio Circuits, Hints
Testing Radio Parts
Transmitters, Operating
Detectors, Metal Locators
Welding Controls, Beacons
High-frequency Heating
Frequency Standards, P.A.
Analyzers, Tube Testers
and hundreds of other topics

LESSONS ON ALL PHASES OF ELECTRONICS AND RADIO

Let this authoritative, easy-to-understand, practical course pave your way into Electronics—the money-making field of the future. Prepare now. Use this training in your spare time to get ahead in a good War-job. Be ready to grab the opportunities in post-war Electronic developments. Let these lessons train you, serve as your teacher and guide, and give you the needed practical time-saving hints on the job. All topics completely indexed — all subjects easy to find.

LIMITED QUANTITY

All three volumes of the *Practical Radio and Electronics Course* have just been printed. Although a large quantity of courses is on hand now, our bargain price will create a tremendous demand. Government (WPB Order L-245) paper limitation policies may prevent reprinting. Better order immediately for examination — no obligation to buy.

SEND TRIAL COUPON TODAY

NEW AMAZING OFFER

New Radio-Electronic Course of 50 large, fact-packed lessons; covers every topic of radio and modern electronics; bound in **three** big manuals and sold **complete** at the unbelievable bargain price of only \$3.95, nothing else to pay. Now is your chance to take advantage of this amazing money-saving offer. Let this home-study course guide you quickly to an essential high-pay job in a radio plant, or in electronic War industry, or help you open your own radio service shop, or aid you in getting higher rank in the Army. Learn radio and electronics to earn more money now; prepare for the coming after-the-war opportunities in Electronics.

THREE COURSES IN ONE

You will find this complete training of 50 large lessons is really **three** distinct courses covering (1) *Practical Radio*, (2) *Applied Electronics*, and (3) *Radio Servicing*. The lessons are clear, practical, interesting, easy to master and use. No special education or previous experience is needed. Notice in the illustration of the manuals, at the left, how the helpful explanations and remarks in the narrow column on each page serve as the teacher. These comments guide you over the hard parts, stress the more important points, show you how to perform many educational experiments using any home-radio. There are hundreds of review self-testing questions, 427 drawings, pictures, diagrams, and service hints. These newly prepared lessons will teach you all about basic radio, transmitters, test equipment, radio servicing, and every topic of Electronics — photo-cells, X-ray, metal locators, airplane beacons, FM, recording, facsimile, welding controls, television, etc.

BE A RADIO-ELECTRONIC EXPERT

Train quickly, in your spare time and in your own home, for a well-paying interesting job in the expanding two-billion dollar radio-electronic industry. You begin with elementary principles and quickly progress to practical explanations of radio building, servicing, and all branches of Electronics. In these well written 50 lessons, experts from every field of Electronics tell you important facts and knowledge which they gained during years of practical experience. These easy-to-follow, well illustrated lessons will give you the useful "know-how" needed to obtain and get ahead on the job. Send "no-risk" coupon today and examine all three volumes in your own home, without obligation.

POST-WAR OPPORTUNITIES IN ELECTRONICS

Electronic applications, devices, and accomplishments, not even imagined a few years ago, are now helping us win the War. Improved and unique new civilian uses of electronics and radio will result immediately after the War. The peace-time advancement in the radio-electronic industry will compare with the rise of the auto industry after the last war. Plan and prepare to be in the midst of this money-making opportunity. Let this lowest priced, home-study course give you the needed training.

Money-Back Guarantee

You must be entirely satisfied or your money will be immediately refunded. You are permitted to make full use of the course for 10 days, on a trial basis
Supreme Publications.

SENT ON TRIAL FOR 10 DAYS

Take advantage of our no-risk examination offer. Send trial order coupon. You will receive the complete **3-Volume Course** for 10 days' use. Begin your radio-electronic study without cost or obligation. If you are pleased, the complete course of 50 lessons, in three large manuals, is yours to keep for only \$3.95, full price, otherwise it costs you nothing for the examination. No risk on your part.

NO RISK TRIAL ORDER COUPON

SUPREME PUBLICATIONS

328 S. Jefferson St. Chicago 6, Illinois

Ship the complete 3-Volume **Practical Radio and Electronics Course** for 10 days' examination. I must be satisfied or you will refund my money in full.

- I am enclosing \$3.95, full price, send postpaid.
 Send C. O. D. I am enclosing \$..... deposit.

Name:

Address:

City: State:

Supreme Publications

PUBLISHERS OF RADIO BOOKS, MANUALS, AND DIAGRAMS

328 South Jefferson Street

Chicago, Illinois

What Chance Have YOU—



For a Secure Peace-Time Future in RADIO-ELECTRONICS?

Now is the time for ambitious radiomen to prepare for a secure engineering job after the war!

If you want peace and security after the war... prepare for it now!

Your present job may last only as long as the war. After that, industry will face a complete readjustment as the country returns to peace-time normalcy and millions of men return from the Armed Forces. Then, once again, the choice jobs will go to those who have the ability and technical knowledge to qualify.

Opportunity is yours, but competition will be keen

The remarkable advancements being made in all branches of Electronics are creating opportunities you cannot afford to overlook. CREI training in practical radio-electronics engineering can give you a sound, technical knowledge, the result of a proven program for self-advancement. We can train you, as we have trained more than thousands of other experienced radiomen for secure, good-paying positions. You can train in your spare time, without interference with your present work, at moderate cost . . . and you can start *right now!*

● WRITE FOR FREE 32-PAGE BOOKLET

If you have had professional or amateur radio experience and want to make more money—let us prove to you we have something you need to qualify for a better radio job. To help us intelligently answer your inquiry—PLEASE STATE BRIEFLY YOUR BACKGROUND OF EXPERIENCE, EDUCATION AND PRESENT POSITION.



CAPITOL RADIO ENGINEERING INSTITUTE

Home Study Courses in Practical Radio Engineering for Professional Self-Improvement

Dept. RN-3, 3224—16th Street, N. W. WASHINGTON 10, D. C.

Contractors to U.S. Navy—U.S. Coast Guard—Canadian Broadcasting Corp.—Producers of Well-trained Technical Radiomen for Industry

mittee on Rescue Equipment, and Office of Production Research and Development. There is also a Canadian exhibit sponsored by the Conservation Committee of the Department of Munitions and Supply.

This visual progress report on the strides made in conservation of materials and manpower by simplification, substitution and mechanical ingenuity, is a tribute to the men and women of America and England.

THAT LONG AWAITED NOMINATION for the vacant commissioner's post in the FCC was made a few weeks ago. FCC chief engineer Jett was President Roosevelt's selection for this post. Unfortunately, this nomination appears to have irked some members of Congress. While everyone in the engineering and broadcasting field, felt that the selection of Mr. Jett was an admirable one, several Republican Senators have decided to think otherwise. They charge that Mr. Jett is not a Republican and thus cannot serve on the Commission since the Commission already has four Democrats and the law specifies that not more than four of the Commission's seven members shall be of the same political affiliation. The appointment of Mr. Jett could, of course, have been made either as a Republican or an Independent. Everyone in Washington feels that Mr. Jett is the logical nominee and hopes that the Senate Interstate Commerce Committee will approve of the nomination. If Mr. Jett's appointment is approved he may also continue to serve as chief engineer of the FCC in view of the absence of three assistant chief engineers, who are now in the services. Incidentally, Mr. Jett, if approved, will be the second engineer to serve as an FCC commissioner. Commander T. A. M. Craven, now a Commissioner, was also an FCC engineer and a colleague of Mr. Jett in the Navy.

Mr. Jett has been publicly commended for his ability not only by the engineering fraternity, but by many members of Congress. Senator White, the father of the Communications Act, and co-author of the present pending bill, is one of the many staunch admirers of Mr. Jett.

Washington looks with interest to the final decision, which we hope will be in the affirmative.

SOUND RECORDED ON MOTION PICTURE FILM is now being used by the Royal Canadian Air Force to supply band music. Thirty-two sound trucks, one for each of the air training stations, now supply the music for route marches, ceremonial parades and drill ground training. The Central Band of the RCAF recorded a series of marches on 16 mm film at the Associated Screen Studios in Montreal. Up to 45 minutes of continuous music are available from each reel of film, supplied with each mobile unit.

There are many interesting features to this recording system. It is possible for the officer in charge to start

and stop the film at will and provide the necessary drum beats or martial music as required. The sound trucks are also used for public address work.

To a former Navy man, Harold W. Soper, goes the credit for this development of the unique method of presenting band music.

FEBRUARY ELEVENTH MARKED the 97th anniversary of one of America's greatest scientists . . . a man whose contributions to radio were epoch-making. We refer to Thomas Alva Edison. Today, more than ever, the Allied nations are grateful for the varied developments of this great American genius. We and millions of others salute Mr. Edison!

FRANK L. SPRAYBERRY, nationally famous as the "Radio Friend" of thousands of aspiring Radio Technicians has just announced the removal of his school's offices and facilities to new and larger quarters in Pueblo, Colorado.

During the past decade, the Sprayberry Academy of Radio has been situated in the nation's capital, Washington, D. C.



From the new site in Pueblo, Colorado, students will continue to receive the marked advantages of new Radio-Electronic Training features which will now be possible as an outgrowth of enlarged facilities. All who know the Sprayberry Academy of Radio join in extending best wishes for continued success in the Academy's new home.

THE CONCLUDING HEARINGS of the committee holding hearings on the White-Wheeler Bill brought forth testimony from some of the Nation's leading radio men. Heard were C. M. Jansky, Jr., technical advisor to the Frequency Modulation broadcasting association; Major Edwin H. Armstrong of regeneration, super-regeneration, superheterodyne and frequency modulation fame; Niles Trammell, NBC president, and John V. L. Hogan, inventor of the ganged variable condenser, part owner of WQXR, the high fidelity station, and holder of dozens of design patents in the radio manufacturing and broadcasting fields.

Mr. Jansky outlined the advantages of frequency modulation from an engineering standpoint to licensing problems and economic situations. He showed that the limitation of the number of stations would be an economic one, instead of an engineering limitation. He stressed the possibilities of thousands of stations on the higher frequencies. His recommendations included the extension of the present frequency modulation band to accommodate a greater number of stations in densely populated areas. He also explained how radio links for networks were quite practical for most F.M. stations.

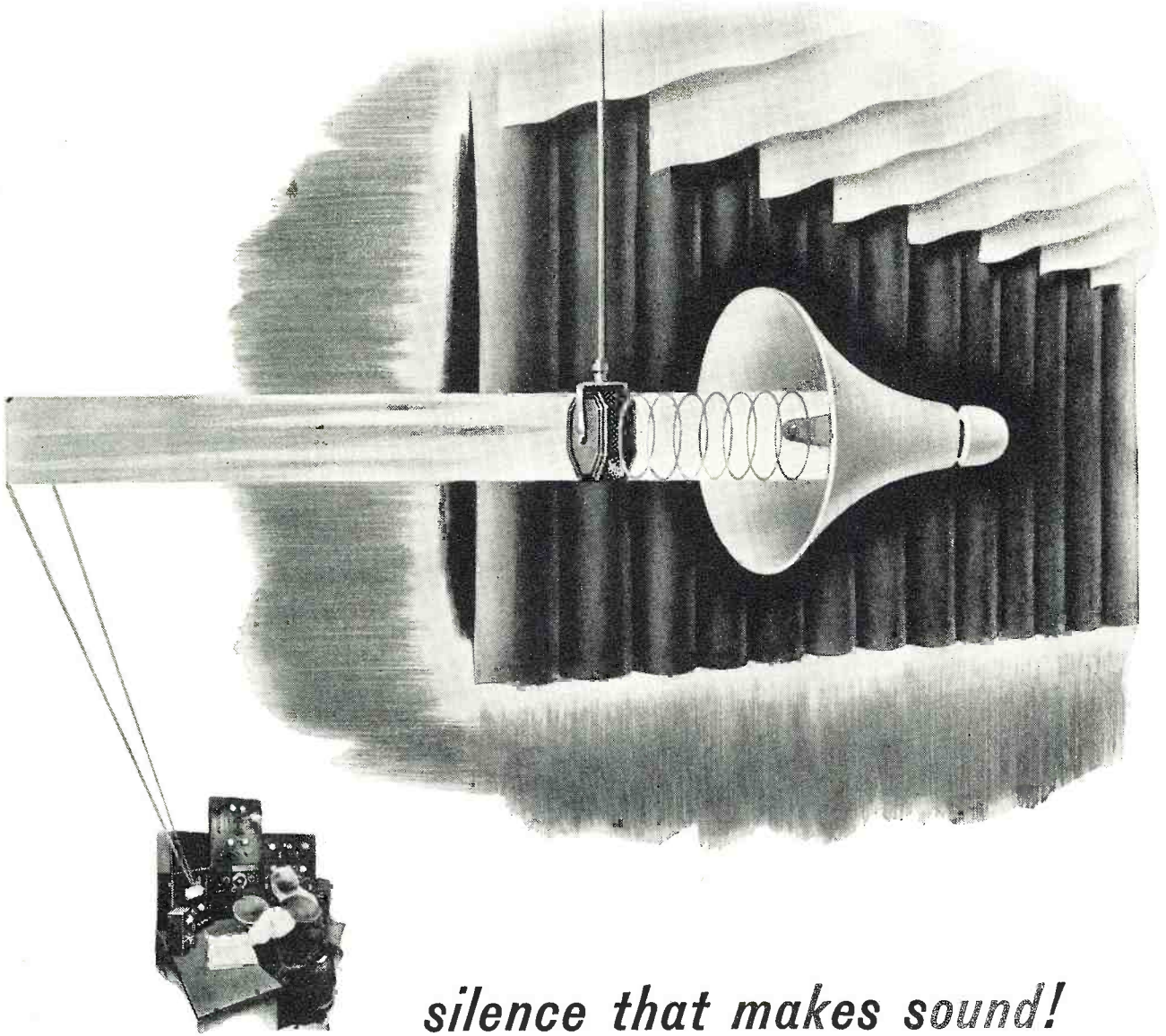

silence that makes sound!

In this "dead" room only the sounds which come out of the speakers are recorded. Sounds which would otherwise bounce back from the walls, ceilings or other objects are trapped and lost forever. The absence of reverberation permits scientifically accurate testing in the sound absorbing room

of Utah's *complete* testing laboratory.

In making practical the many war-created radio and electronic improvements—in adapting them to today's needs and for the commercial requirements ahead, Utah engineers have designed new parts and products, developed new manufacturing devices and

methods and have instituted new, more comprehensive testing techniques.

★ ★ ★

Every Product Made for the Trade, by Utah, Is Thoroughly Tested and Approved

Utah

Radio Products Company,

824 Orleans Street, Chicago 10, Illinois

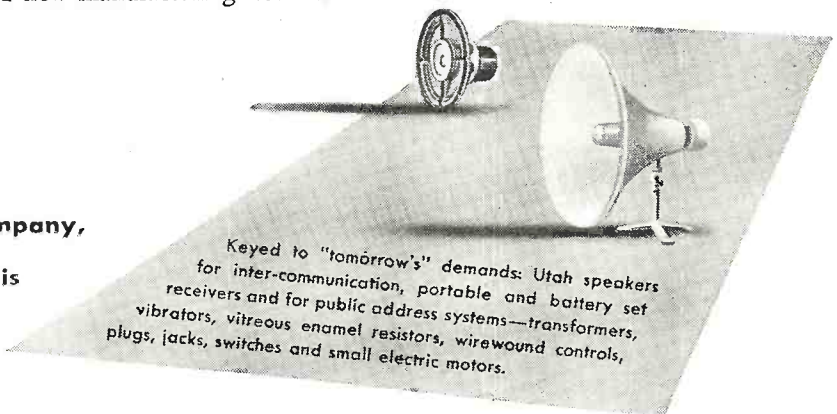

Keyed to "tomorrow's" demands: Utah speakers for inter-communication, portable and battery set receivers and for public address systems—transformers, vibrators, vitreous enamel resistors, wirewound controls, plugs, jacks, switches and small electric motors.

Major Armstrong in his testimony paid tribute to the FCC and Chairman Fly. He said that Mr. Fly had given F.M. its greatest impetus during the Commission's 1940 investigation of the possibilities of F.M. However, since that time, Major Armstrong explained, through failure of making available F.M. relay channels, development of F.M. has been retarded. He recommended that television channel number one be allocated to F.M. Such allocation, he said, would not adversely affect television, for television should operate on the higher frequencies to afford a national service and accommodate sufficient licensees.

Many vital changes in the communications law were suggested by Mr. Trammell in his testimony. He suggested that radio broadcasting be guaranteed by definite declaration, full rights under the First Amendment to the Constitution. He recommended that licensing authority be prohibited from exercising any business or program control of broadcast station operation. He also recommended that the license for a broadcasting station be revoked only by Government suit in the Federal court where the station is located, with trial by jury. In this instance the Government would be authorized to prosecute such com-

plaints only for specified clauses such as are now provided in the Communications Act.

Testimony of Mr. Hogan covered phases of television, F.M., facsimile and recording. In discussing recording, Mr. Hogan said that transcribed programs are better than live programs produced over long distance wire lines which are presently in use. He pointed out, though, that wire line quality can be and has been, on short distances, increased to 16,000 cycles. The question, he said, is one of economic feasibility. In his concluding remarks, Mr. Hogan paid tribute to the broadcasting industry at large.

He said, "I may be radical with respect to the view that I have, that decent people do a decent job. I think that our broadcasting industry has done a really excellent job. It started with no regulation whatever and it has been doing a good job since then. The only time it went haywire was . . . (during the breakdown of the law when the government was precluded from withholding licenses, assigning frequencies, designating time of operating power of stations). At that time some men ran amuck . . . no doubt about it . . . proving the necessity of the type of regulation we are talking about, but I have not seen any improvement in the effectiveness of broadcasting as a public service that is consequent upon any attempt to regulate programs externally by the Commission or by law, or any attempt to regulate the business by the Commission or by law. I have never seen a useful result come of that. . . . I trust that you will include a really strong injunction that all proper consideration be given to the development of new service in radio service . . . the maximum encouragement you can do for these things because without these things, there is no progress."

According to present activities of the Senate Interstate Commerce Committee, which is whipping into shape a revised draft of the White-Wheeler Bill (S-814), Congress will probably soon take concerted action on this legislation to provide a new Communications Act.

PHONOGRAPH RECORDS ARE BEING PRODUCED IN AFRICA according to the Department of Commerce. A suitable supply of domestic raw materials has been established. The manufacturer has had previous experience in producing records on a production basis, and thus far the monthly production is expected to approximate 50,000 records. According to reports, the records already produced are excellent in quality, comparing favorably with those produced in this country.

ONE OF THE MOST CONTROVERSIAL BILLS IN A DECADE, the science mobilization bill or Kilgore Bill, S-702, is still awaiting action in Congress. It was introduced in the 78th Congress by Senator Harley M. Kilgore (Democrat, W.Va.), "to mobi-

ELECTRICITY for RADIO WORK ANYWHERE

This unit is from
W2C Series

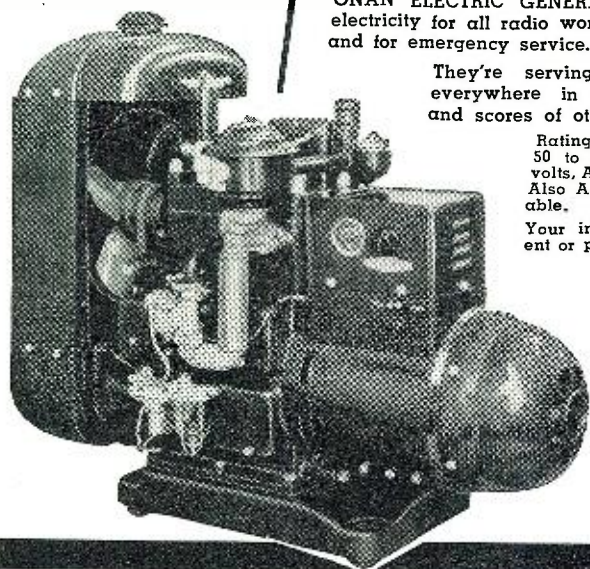

ONAN ELECTRIC GENERATING PLANTS furnish electricity for all radio work, stationary or mobile, and for emergency service.

They're serving our Armed Forces everywhere in communications work and scores of other war tasks.

Ratings, 350 to 35,000 watts. 50 to 800 cycles, 110 to 660 volts, A.C. 6 to 4000 volts, D.C. Also A.C.—D.C. models available.

Your inquiry regarding present or post war needs will receive prompt attention. D. W. ONAN & SONS, 1888 Royalston Ave., Minneapolis, Minn.

Awarded to each of the four Onan manufacturing plants

ONAN
ELECTRIC PLANTS



Send for
FREE
COPY!

PROVED ELECTRICAL ASSEMBLY PROCEDURE

Amphenol's new 28-page illustrated booklet, OK METHODS, provides an exchange of ideas for faster production on electrical assembly lines—fully tested procedures, proved in use. The many suggestions may be helpful in your assembly problems. Request your copy today.

AMERICAN PHENOLIC CORPORATION
CHICAGO 50, ILLINOIS
IN CANADA—AMPHENOL LIMITED • TORONTO

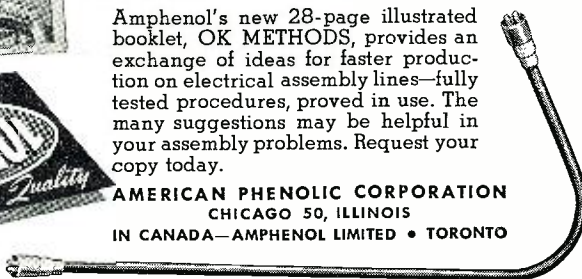



What Price Pilots?

UnCLE Sam takes a new recruit of top-notch physical and mental ability, and makes a combat pilot of him in two years, at a cost of \$30,000.

Trained and equipped* to perfection, he will be a sure-fire success as a fighting man. But what about the day his combat job is finished — can we be as certain that he will come back to

a nation of opportunity and prosperity?

Regular, substantial investment in war bonds is a double-edged sword that helps fight the war and assures a prosperous postwar economy. It is your duty and ours to encourage those who work with and for us to invest regularly and substantially . . . for everybody's future.



* Among our contributions to his equipment are communications equipment and aircraft ignition components. Connecticut Telephone and Electric Division employees are over 99% pledged to regular payroll deductions on an average of 15% of their incomes.

CONNECTICUT TELEPHONE & ELECTRIC DIVISION

MERIDEN



CONNECTICUT

© 1944 Great American Industries, Inc., Meriden, Conn.

Gothard

VIBRATION RESISTING SHUTTER TYPE PILOT LIGHT

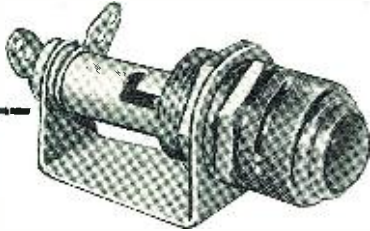

Gothard No. 431 Pilot Light is used in aircraft, ships, tanks, signal and similar applications where vibration is an important factor. Precision, snug fitting jewel and lens holder maintains set position. 90° rotation of shutter provides gradation of light from bright, through intermediate glows, to dim glow, or total dark. Faceted or plain Jewels. Also available with polarized lens. Red, green, amber, blue or opal lens.

Write for complete information

Gothard
MANUFACTURING COMPANY
 1350 N. NINTH ST., SPRINGFIELD, ILL.

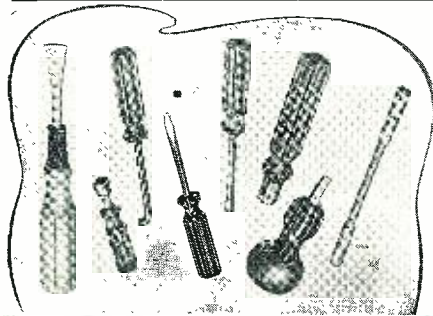

Which One?

Every one of these Vaco special drivers and small tools is performing some unusual service in industry.

In the radio and electronic field, we have created and produced, labor and time saving Vaco Amberyl-handle shock-proof and break-proof drivers and tools, in use everywhere, by radio men on the home front as well as on the battle-fronts.

Our regular catalog contains 173 standard numbers. Write for further information.

VACO PRODUCTS COMPANY
 317 E. Ontario St. CHICAGO 11, ILLINOIS
 Canadian Branch Warehouse
 560 King St. W. Toronto 8, Ont.

lize the scientific and technical resources of the nation, to establish an Office of Scientific and Technical Mobilization, and for other purposes." Unfortunately, there are many phases of the bill which are proving disturbing to many scientists. For instance, in the section of the bill providing for the administration of the office, we find that the qualifications of the administrator who is appointed by the President are not specified. Insofar as the bill is concerned, the appointee can be a political one without any scientific background. In addition, the bill does not define the terms "scientists" or "technologists" who are also appointed by the President. If such appointees fall within the scope of "scientific and technical personnel," persons (according to present standards) with "not less than an aggregate of six months training or employment in any scientific or technical vocation" could be appointed. It is entirely possible, therefore, that even apprentices might qualify for membership on the science board.

Another impractical portion of the bill concerns the National Scientific and Technical Committee. On this Committee, according to the bill, would appear members of the board in addition to nineteen and "x" members. The "x" members represent "one representative each, for each of such Federal departments as the President shall designate." The group of nineteen include four from the consuming public, three scientists or technologists, six from labor and six from management in the major fields of production and service. The representation of science on the committee is quite obviously weak.

The bill also provides for the Office of Scientific and Technical Mobilization to have exclusive control of any invention, discovery or patent arising out of any project to which the Government has made any contribution since May 27, 1941, or as the bill says, "shall hereafter contribute." Thus, the Office is apparently authorized to act as a patent licensing agency. In addition, the bill calls for the transfer of the National Roster of Scientific and Specialized Personnel to the office just mentioned, with full control over occupational deferment.

The bill actually dissolves the National Research Council and the National Academy of Sciences.

Accordingly, it is apparent that the bill tends to destroy the freedom of effort and enterprise in research and development. According to this bill, scientists might become robots. While there is no doubt that deficiencies do exist in many science procedures this bill does not alleviate the situation. Substitute measures are being studied for early presentation. Everyone looks forward with interest towards Congressional action on the pending and substitute bills.

THE SHORTAGE OF SHELLAC HAS PROMOTED the development of many substitutes. The latest sub-

stitute to come to our attention is a new synthetic known as Luckite formula 7-11-A. According to the chemists who have developed this substitute, phonograph records made with it appear to provide results superior to standard shellac records. They say that this is due to the fact that the synthetic has a finer grain. The actual wear is also slight, in comparison to the standard records, they say. Tests

MASTER DRAFTING MACHINE

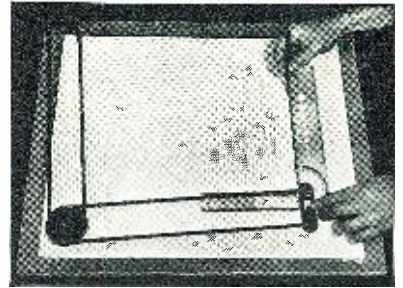

• **Biggest time-saver for dimensioned sketches, lettering and layouts ever sold at this low price. Size, 20"x24". Limited supply. While they last only \$3.95**

Order Today!

RANDOLPH RADIO
 609 W. RANDOLPH ST., CHICAGO 6, ILLINOIS

CABINET SPECIALS

Replacement cabinet in dark walnut finish plastic. Inside dimensions 10W x 6½H x 6D.
 Price..... **\$1.95**

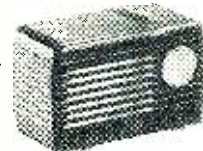

Dark walnut finish plastic cabinet to accommodate practically any Tiny Tim radio. Size 7¾W x 4¾H x 4D.
 Price..... **\$1.50**

Also blank table cabinets of walnut veneer in the following sizes:

8¼W x 5½H x 4D	\$1.95
10¼W x 6¾H x 5D	\$2.75
13½W x 7¾H x 6¼D	\$3.25

14" SPEAKERS

14" electro-dynamic speakers. 900 ohm field, 6-8 ohm voice coil. 6V6 push-pull transformer. 15 watt output. Special, only..... **\$4.49**

All types of radio parts available in today's market can be obtained at Lake's money-saving prices. Large stock listed in our new Bargain Bulletin. Write us for your copy. It's free.

LAKE RADIO SALES CO.
 615 Randolph Street Chicago 6, Ill.

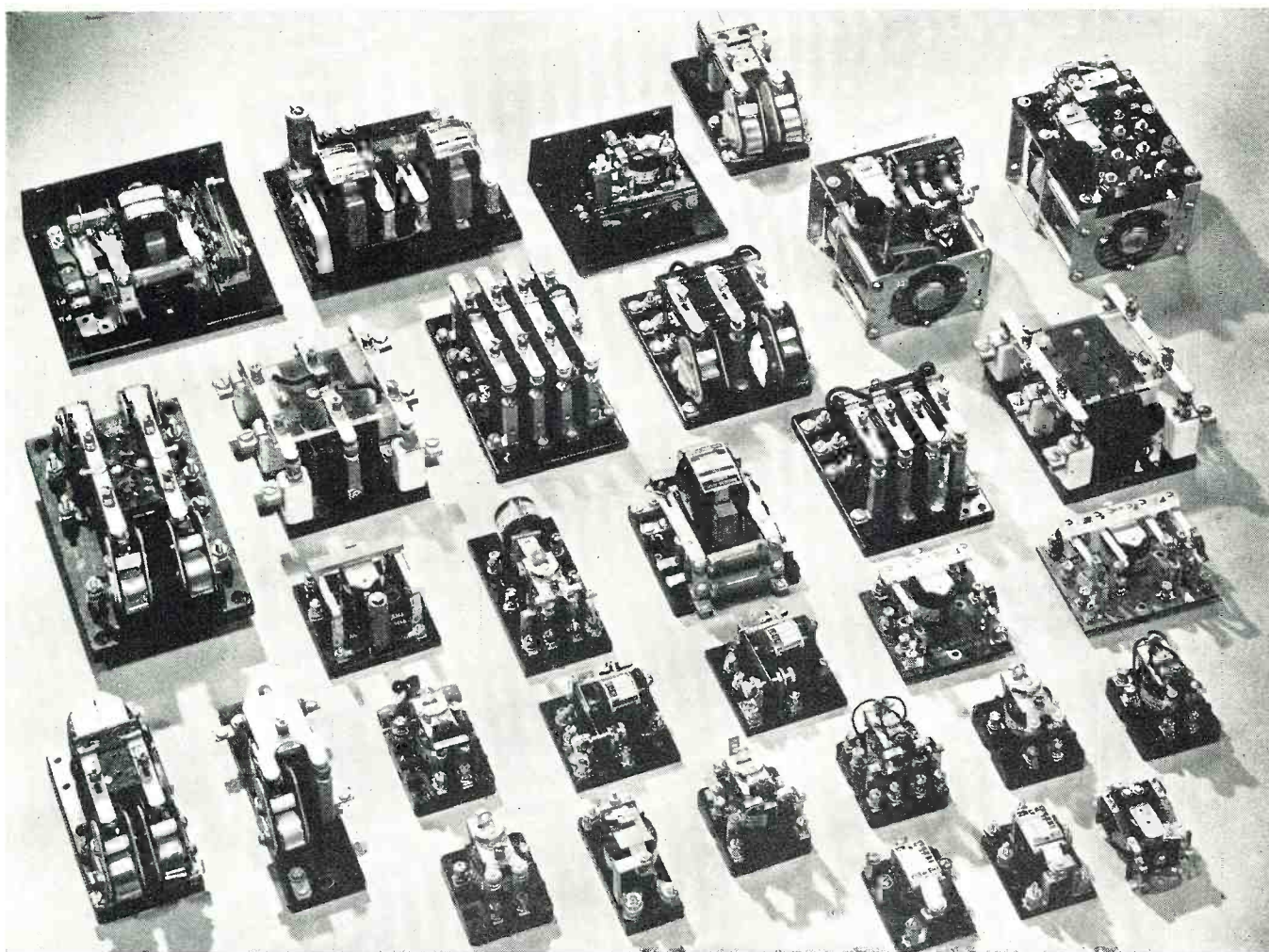

BULLETINS TELL THE WHOLE RELAY STORY

When you can select the relay that exactly meets your requirements from a regular line, you have saved man power, time and money. WARD LEONARD RELAYS include types and sizes for every

application. They all have crisp action, are dependable and durable yet consume but little current. Send for the data bulletins of interest to you.

RELAY BULLETINS

Bulletin 105

"Little Giant Relay" single pole, single and double throw. Controls $\frac{3}{4}$ HP on 115-230V.

Bulletin 106

Midget Relays for light duty available in single and double pole, single and double throw.

Bulletin 81

Intermediate Duty Relays in single and multipole arrangements, single and double throw.

Bulletin 362

Motor Driven Time Delay Relays for operation on alternating current.

Bulletin 104

Midget Relay for tight places—Vibration resistant—Double Pole, Double Throw—Available for 6 to 115 volts A.C. or D.C.

Bulletin 131 and 132

Heavy Duty Relays single and multipole, single and double, contracts rated up to 25 amp. on 125-250V.

Bulletin 251

Sensitive Type Relays for direct and alternating current operating on .014 watts.

Bulletin 351

Thermal Time Delay Relays with thermostat built into relay assembly.

Bulletin 103

Aircraft Power Relay. Single Pole, Single Throw for 24 volts at 25 amps. D.C. Withstands high values of acceleration of gravity, shock, and vibration.

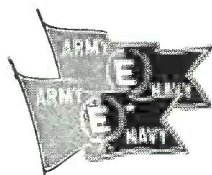

WARD LEONARD

RELAYS • RESISTORS • RHEOSTATS

Electric control  devices since 1892.



Midget Metal Base Relay measures $1\frac{1}{4}$ inches high for tight places in aircraft radio and control circuits where space is limited.

WARD LEONARD ELECTRIC COMPANY, 47 SOUTH STREET, MOUNT VERNON, NEW YORK

March, 1944

103

RADIO CHASSIS PUNCH



Saves hours of work cutting clean, accurate holes in radio chassis—for connectors and other receptacles. Simply insert cap screw in hole to be enlarged (drill small hole if necessary), turn with ordinary wrench to force punch through the metal. No reaming or filing—hole is smooth and clean. No distortion—die supports metal. Ten sizes from $\frac{1}{8}$ " to $2\frac{1}{4}$ "; also up to $3\frac{1}{2}$ " for meters. Write for free catalog 33E to Greenlee Tool Co., 1883 Columbia Ave., Rockford, Ill.



Serving the Armed Forces
...AND THE HOME FRONT, TOO!

- Despite material and manpower difficulties, and our participation in the war effort, we are producing and delivering the Government-approved Victory Line of Condensers. Write for list of Victory items and prices. Shipments are made on L265 Ratings, or better.

For VICTORY Buy United States War Bonds and Stamps

POLYMET CONDENSER CO.
 699 E. 135th ST., NEW YORK 54, N. Y.

have also shown that the scrap can be worked, milled and molded over repeatedly.

The raw materials used to produce records employing this synthetic shellac are most interesting. They are: manila and other copals, resin, cotton flock, asbestine, carbon and bone black, nigrosine dye and mineral fillers.

There are several other synthetic shellacs in the process of development. It appears as if there will be undoubtedly a variety of postwar phonograph records produced from synthetic shellac.

FOR CONTINUED EXCELLENCE in production a star has been added to each of the Army-Navy E pennants flying over the four Raytheon Manufacturing Company divisions.

In the closing paragraph of his award letter to Raytheon, Admiral C. C. Block, Chairman of the Navy Board for production awards stated, "The Navy Department extends to each and every man and woman of your Company its hearty congratulations on their accomplishments, and desires to express a fervent hope that future production will be even more outstanding."

TELEVISION HAS WON ITS SPURS in one important Washington department already. The Department of Interior which had a section devoted to radio has now included television in that section. This division will hereafter officially be known as the Radio and Television Section. This is the first Government agency to accept television as a major project.

The annual report of the Department of Interior shows that radio was used by twenty agencies of the Government during the past year. Shannon Allen is director of the section now devoted to radio and television activities.

THE ARMY-NAVY "E" production award was presented to the employees and officials of the Bell Sound Systems, Inc., 1183 Essex Avenue, Columbus, Ohio, on Thursday, December 2nd. Honorable Paul M. Herbert, Lieutenant Governor of Ohio, served as master of ceremonies and delivered the main address. Colonel H. R. Yeager, commanding officer of the Signal Corps, Aircraft Signal Agency, Wright Field, Dayton, Ohio, made the presentation address and presented the flag to Mr. Floyd W. Bell, President of the company, who in turn made the acceptance speech.

Personals . . .
Haraden Pratt, vice president and chief engineer of MacKay Radio and vice president of Federal Telephone and Radio Corporation, was awarded the medal of honor by the IRE at its annual winter conference in New York . . . **Vannevar Bush**, president of the Carnegie Institution of Washington and director of the Office of Scientific Research and Development, re-

"The Inductance Authority"
 by Edward M. Shiepe
 B.S., M.E.E.

The only book of its kind in the world. Listed by the Government among the recommended technical books. 38 full page 9x12 charts and ten pages author's instructions on how to figure all types of solenoid coils. Saves ten times its cost in tedious and time-consuming calculations. Check your work with the charts and avoid costly errors.

\$2.50 Postpaid.

GOLD SHIELD PRODUCTS (Dept. RN3)
 350 Greenwich St., New York 13, N. Y.

Short-Cut Mathematics
 COMBINED WITH
Practical Mechanics Simplified

NEW 2-in-1 reading course! Now you can learn the speedy, simplified system of calculation used by draftsmen, engineers, accountants, "master minds" on the stage. Learn easy way to multiply 4 figures by 4 figures without using old-fashioned multiplication; add long columns of figures this lightning short-cut method. Learn horsepower, slide rule, micrometer, logarithms, wood measure, puzzles, etc. Large illustrated volume complete with answers, only \$1 postpaid. Satisfaction or refund. Amaze friends with your magic-like mental powers.

FREE Complete details... mail coupon TODAY!

NELSON CO., 321 S. Wabash, Dept. 309-C, Chicago
 Please send free details about "Short-Cut Mathematics and Practical Mechanics Simplified." No obligation.

Name
 Address

SEND COUPON

B. M. Klekner, Executive Director
 Radio Training Association of America,
 437 1/2 N. Beverly Drive, Dept. ORN
 Beverly Hills, California, U. S. A.

Dear Mr. Klekner: Please send me free information and facts about Radio Opportunities and how I can train in my spare time for a BIG PAY JOB in Radio.

Name
 Address
 City
 State Country.....

ELECTRONICS BOOK Headquarters for the West

We stock many of those hard-to-get radio and electronics books, McGraw-Hill, Wiley, Van Nostrand, Rider, Ghirardi, many others. Mail orders handled at publishers' prices plus 4% for postage; please add any applicable taxes. Send 3c stamp for catalog. Telephone inquiries welcomed; Hillside 3429.

EDITORS AND ENGINEERS
 1420 No. Highland Ave. Los Angeles 28

GOOD JOBS in RADIO
For Both Men and Women

Prepare now for jobs in Radio Engineering; Broadcasting; Marine, Aviation, Police Radio; Servicing; Radio Manufacturing. Our streamlined courses give excellent preparation for Army and Navy Service Expenses low. Write for free catalog.

VALPARAISO TECHNICAL INSTITUTE
 Dept. M, Valparaiso, Ind.

RADIO ENGINEERING DEGREE IN 27 MONTHS

Intensive, specialized course, including strong basis in mathematics and electrical engineering, advanced Radio Theory and Design. Modern laboratory. Low tuition. Self-help opportunities. Also 9-month courses in Aeronautical, Chemical, Civil, Electrical and Mechanical Engineering. Enter Mar., June, Sept. & Dec. Catalog.

INDIANA TECHNICAL COLLEGE
 724 E. Washington Blvd., Fort Wayne 2, Ind.

GET INTO RADIO

ELECTRONICS TELEVISION *Now!*



Checking performance of a radio-telephone transmitter with an oscilloscope. National trained Radio Technicians, in Broadcasting Stations, in Industrial Plants and in business for themselves are well paid specialists. Their services are in urgent demand.

Shortages in trained, skilled men run into the hundreds of thousands. Wartime demands for Radio men are tremendous and will continue UNABATED after the war. The developments in all branches of electronics point to an unlimited future. That's important to you. You want training in a field that will continue to advance. National Schools offers you a time-tested method of Home Training which has helped thousands of men to more pay, and unlimited opportunity in a vigorous and expanding industry.

Shop Method Home Training by a Long Established Resident School

Here is your opportunity to get the sound, practical up-to-date knowledge in Electronics, Television, Frequency Modulation and other latest developments in Radio. This is not just instruction in theory. It is a real, down-to-earth course based on the shop training that has been developed and improved by National Schools' methods since 1905.

EASY TO LEARN THE NATIONAL WAY

Now, right at home, you can prepare quickly to be of greatest service to your country and yourself. Yes, right at home in your spare time. National's time-tested plan of Home Training will definitely establish you. In a short time, you can hold a good job in this fascinating field. Furthermore, you become equipped for an ever bigger career in the years of reconstruction after the war.



RADIO EQUIPMENT INCLUDED

You work with real radio equipment and materials which we furnish. During your National course you build experimental units, check circuits—get real practice with tools and parts. You learn by doing and in a short time you are ready for your first job in radio.

Take the important step now. Fill out and mail the coupon at once.

TRAIN DURING MILITARY SERVICE



Prepare for Radio Service in Army and Navy. In U. S. Gov't. service you install, operate and maintain most technical equipment such as secret ultra-high frequency apparatus to locate airplanes, submarines, etc. Get promotion in rank and increased pay almost from the start.

START EARNING EARLY

Many beginners start earning extra money even before they have finished their National training. They are needed for radio repair work in plants and factories, in part-time work in broadcasting studios. No previous experience is needed to start. National training is so simple and practical that every step of the way seems natural. You get ahead fast and in a very short time you have a sound grasp of technical terms, tools, parts and equipment.

GREAT POSTWAR DEMAND

Radio is only one of the courses you receive when you become a National Student. Electronics is brand new and open to every trained radio man. After this war it will produce new marvels that will be needed and used in every home. General Electric, Westinghouse and all great manufacturers have many new electronic inventions ready to market. National men, because of their knowledge and training, will be among the first to cash in. Television is a *big new opportunity*. National men will have the "know how" to merit jobs in this great industry.

COMMAND ANY OF THESE JOBS

Radio Expert
Electronics Engineer
Radio Broadcasting
Studio Technician
Television Technician
Aviation Radio
Ship & Harbor Radio
Business of Your Own
Industrial Sound

137 Different Types of Jobs to Choose From

NATIONAL GRADUATES WIN GOOD JOBS



"I have been in the broadcasting field since graduating from National. Am with Station WIBX. I recommend your School."—Fred Hoffman, Utica, N. Y.



WITH BIG FIRM

"Am employed at General Electric plant in Bridgeport as inspector on Radio for Army and Navy. I owe a great deal of my success to National Training. Wish I could see your instructors and tell them of my good luck National has brought to me."—Chas. Plunkett Danbury, Conn.

NATIONAL SCHOOLS

LOS ANGELES 37, CALIFORNIA
EST. 1905



MAIL OPPORTUNITY COUPON FOR QUICK ACTION

National Schools, Dept. 3-RNR
4000 S. Figueroa Street
Los Angeles 37, Calif.

Mail in envelope

or paste on penny postal

Please rush me, FREE and without any obligation on my part, Sample Lesson in Radio, Television and Electronics and full details of your "Shop Method" of home training. No salesman will call.

Name..... Age.....

Address.....

City..... State.....

FREE LESSON

and Opportunity Book

To prove that you can easily learn radio at home by National's famous "Shop Method" home training, we will send you this sample LESSON without cost or obligation. With it, we will send you a big, 36 page book, "Your Future in Radio, Television and Electronics."

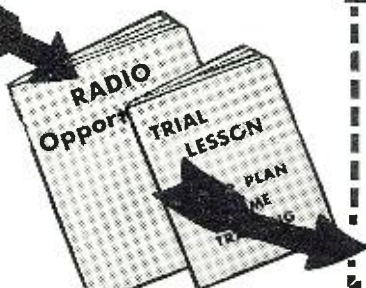

NOW—A REALLY HIGH-POWERED— Radio Engineering Library

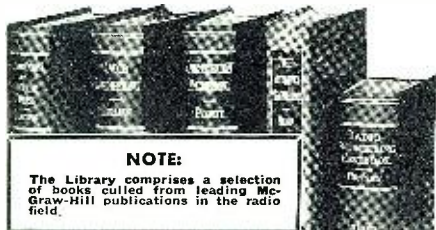

NOTE:

The Library comprises a selection of books culled from leading McGraw-Hill publications in the radio field.

- especially selected by radio specialists of McGraw-Hill publications
- to give most complete, dependable coverage of facts needed by all whose fields are grounded on radio fundamentals
- available at a special price and terms

THESE books cover circuit phenomena, tube theory, networks, measurements, and other subjects—give specialized treatments of all fields of practical design and application. They are books of recognized position in the literature—books you will refer to and be referred to often. If you are a practical designer, researcher or engineer in any field based on radio, you want these books for the help they give in hundreds of problems throughout the whole field of radio engineering.

5 VOLUMES, 3319 PAGES, 2289 ILLUSTRATIONS

1. Eastman's FUNDAMENTALS OF VACUUM TUBES
2. Terman's RADIO ENGINEERING
3. Everitt's COMMUNICATION ENGINEERING
4. Hund's HIGH FREQUENCY MEASUREMENTS
5. Henney's RADIO ENGINEERING HANDBOOK

10 days' examination. Easy terms. Special price under this offer less than books bought separately. Add these standard works to your library now; pay small monthly installments, while you use the books.

10 DAYS' FREE EXAMINATION—SEND COUPON

**McGRAW-HILL BOOK CO.,
330 W. 42nd Street, New York 18, N. Y.**

Send me Radio Engineering Library, 5 vols., for 10 days' examination on approval. In 10 days I will send \$3.00 plus few cents postage, and \$9.00 monthly till \$24.00 is paid, or return books postpaid. (We pay postage on orders accompanied by remittance of first installment.)

Name

Address

City and State

Position

Company RN-3-44

Back the 4th War Loan Drive



BURSTEIN-APPLEBEE CO.
1012-14 McGee St. Kansas City, Mo.

RADIO ENGINEERING!

Radio today offers great future for women as well as men. Demand for graduates exceeds supply. Courses also in Civil, Electrical, Mechanical, Chemical, Aeronautical Engineering, Business Administration, Accounting, Secretarial Science. Tuition, living costs low. 61st year. Cosmopolitan student body. Enter March, June, Sept., Jan. Catalog.

DEGREE IN 27 MONTHS

TRI-STATE COLLEGE 1634 College Ave. Angola, Ind.

ceived the 1943 Edison medal of the American Institute of Electrical Engineers . . . **Orrin E. Dunlap, Jr.**, manager of RCA's department of information, is now director of advertising and publicity for RCA. He succeeds **Horton H. Heath** who is now with NBC as assistant to **Frank Mullen**, vice president and general manager. Mr. Dunlap was formerly radio editor of the New York Times . . . **Colonel Albert L. Warner**, former CBS Washington correspondent has been appointed chief of the War Department press branch in the Bureau of Public Relations. He succeeds **Colonel J. Noel Macy**, president of the Westchester Broadcasting Corporation . . . **E. K. Cohan** has resigned as director of general engineering of CBS . . . **William B. Lodge** has resumed supervision of Columbia's general engineering design and developmental activities . . . **Sam Curtis**, former chief engineer of WNAC, Boston, died recently. He was one of the Nation's early pioneers in radio, having received a license to operate in 1912 . . . **Reau Kemp**, well-known sales executive in the radio and household appliance field, has resigned from the Washington office of the War Production Board to accept a position as Sales Director with the Warwick Manufacturing Corporation.

-30-

QTC

(Continued from page 40)

Apparently Maritime has now come to the point where it can "pick its man" rather than the former policy of taking everyone who came along and trying to make radio officers of them. For those who are really interested in marine radio and want to get into the game it's a good chance to get started and to get good training at no cost, something that can't be done in peacetime. It costs real cash then to get marine radio training. Applications for training in the Maritime Service can be made at any of the recruiting centers in the larger cities and ports. In New York the office is at 45 Broadway, local offices are located in Newark, N. J., and upstate in Buffalo.

FISHERMEN'S strike was recently settled and everyone has gone back to work—the trawlers have been tied up for the past couple of months. Tankermen unloading in a rather "one-sided" neutral port this winter report their cargo loaded directly into Nazi oil cars and started on its way to Hitler & Company as fast as it could be taken out of the tanker. If this is actually the case, looks like someone is trying to play both ends against the middle.

A. FAREI has taken out a new cargo assignment. Ernest MacDowell left the deep blue ocean for a new berth ashore. E. Richardson and A.

Rattigan have taken out new assignments from the East Coast. Leif Hvidsten has been transferred to a Mississippi flying field since joining the Air Corps. H. Roberts is back after a trip on his tanker during which his craft was suffering from "engineitis"—he reports back from the shipyard again and says its beginning to look like home now.

Apparently there is still a demand for good radio technicians—letter from Otis Hill, Hawaiian Airlines Limited, Inter-Island Building, Honolulu, in which he mentions he could use a couple of good men for a permanent job. "O. H.," who resigned from the old "Maui" in 1927, is Superintendent of Communications for the above outfit, so if you're looking for a steady job with a postwar future, get in touch with him. Otis sends along a couple of items. Reports P. A. T. Hendricks, an old-time brass pounder for many years, dropped in to see him not long ago. Hendricks is now Chief Operator on a large passenger liner that formerly sailed out of San Francisco. Charlie Cross, formerly of Matson Navigation Company, has settled down with a nice little wife and is connected with the Berkeley Police Department. R. L. Simpson, ex-Chief on the "Maui," is now a Warrant Radio Officer in Uncle Sam's Navy somewhere "Down Under." Another old time Matson man, Jeff Lloyd, is now with the USED out in Honolulu.

Another letter informs us that the writer has been getting the ole "pass the buck" story between draft board, union and Maritime Commission. There have been more like this one which reads, in part: "I received my license around the first of November, obtained my seaman's papers and was put on the Union list. A month later I found that they had taken my name off the list with the explanation that the draft board had to approve my being on the list before I was eligible. I received a note from them stating that they didn't consider that sufficient for a deferment even though I have two children. They wanted me to do something else. When I saw the board personally they told me I had to have an O. K. from the War Shipping Administration before I could have permission to get on the Union list. The W.S.A. told me they could do nothing until I had actually signed articles. The Union couldn't put me on the list without the draft board's O.K." That sure is the old run-around in modern style. You can not well blame men who have gone to the time and trouble to learn marine radio and then receive treatment like the above.

L. Hulme and S. Saumle both are out on new assignments from the East Coast as is R. Greaves. G. Rostad is out on a new tanker billet for a change. Vincent Willex and L. Naugen have new cargo jobs that will keep them busy for awhile. Assignment turnover is generally slow after the past holidays, which is to be expected.

-30-

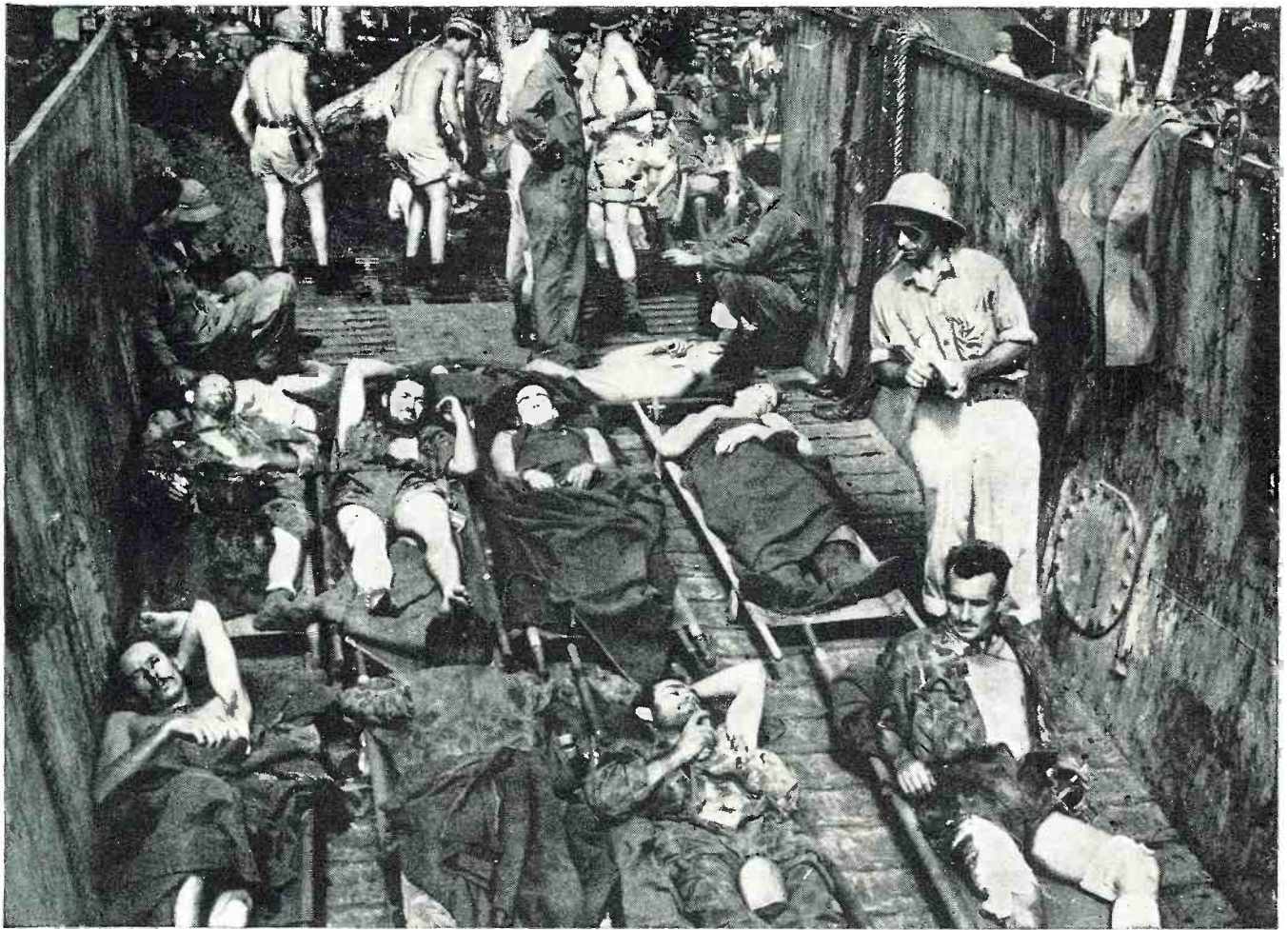

Pin-up picture for the man who "can't afford" to buy an extra War Bond!

YOU'VE heard people say: "I can't afford to buy an extra War Bond." Perhaps you've said it yourself . . . without realizing what a ridiculous thing it is to say to men who are dying.

Yet it *is* ridiculous, when you think about it. Because today, with national income at an all-time record high . . . with people making more money than ever before . . . with less and less of

things to spend money for . . . practically every one of us has extra dollars in his pocket.

The very *least* that *you* can do is to buy an *extra* \$100 War Bond . . . above and beyond the Bonds you are now buying or had planned to buy.

In fact, if you take stock of your resources, and check your expenditures, you will probably find that you can

buy an *extra* \$200 . . . or \$300 . . . or even \$500 worth of War Bonds.

Sounds like more than you "can afford?" Well, young soldiers can't afford to die, either . . . yet they do it when called upon. So is it too much to ask of us that we invest more of our money in War Bonds . . . the best investment in the world today? Is that too much to ask?

Let's all BACK THE ATTACK!



ZIFF-DAVIS PUBLISHING CO.

This is an official U. S. Treasury advertisement—prepared under auspices of Treasury Department and War Advertising Council

March, 1944

107

What's New
(Continued from page 49)

The complete instrument is small, light in weight, and economical to operate. It is enclosed in an attractive, portable walnut case, the cover of which may be removed so that the instrument can be placed on a shelf or stand in full view of the operator. In addition, the well-illuminated dial permits the scales to be read easily even in poorly lighted locations.

SPRING-LOCK FASTENER

Elastic Stop Nut Corporation of America, Union, N. J., announces that they have acquired world rights to a new fastener which will add to the scope of the company's work in present war production as well as in postwar commercial use. The new fastener is a spring-lock device invented by Dr. E. L. Mack, and perfected by the Aircraft Parts Development Corporation, Summit, N. J., under the direction of D. C. Hungerford.

The new fastener is a lightweight unit of extremely rugged construction and is particularly suited for holding the engine cowlings of high-speed war planes. The Army Air Forces have tested it at Wright Field and have found that it meets specifications for use in any Army airplane. Also, after complete testing, the Navy's Bureau of Aeronautics has found that it meets

Navy specifications for aircraft of that branch of the service.

In addition to its important uses on airplanes, this fastener is suited to many postwar commercial applications, such as access plates on farm machinery, panels on motor trucks, home heating units, radio equipment,

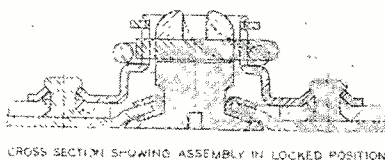
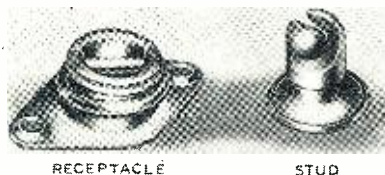

and at any point where a quick-acting vibration-proof non-rattling fastening is needed.

The addition of this fastener to the Elastic Stop Nut Corporation's production further enhances its position in supplying high-grade fastenings of all types as part of the Postwar Planning Committee's program for being in a position to furnish special fastenings which will be required for the heavy postwar production of radio equipment, automobiles, rail and bus lines, and other uses.

in 4 oz. containers with applicator, also pints, quarts and gallons.

Further details regarding this product may be had by writing to E. Karelson, Inc., 125 West 45th St., New York.

VACUUM TUBE CHART

It has been announced by National Union Radio Corporation, Newark, N. J., headquarters that a Visual Aid Vacuum Tube Chart for instruction purposes has just been published.

The Chart, measuring 30" by 45", is noteworthy for its technical excellence and detail and shows all parts of a typical radio tube individually and in relation to the final construction. It also contains element classifications and symbols for diodes, triodes, tetrodes, pentodes and multi element and multi unit types including diode triode, double triode, diode pentode and pentagrid converters. Sketches of base pin arrangements and numbering systems for vacuum tubes are also included.

The Charts are printed on heavy paper for years of service. They are equipped with wooden dowels top and bottom to facilitate hanging on laboratory or classroom walls.

Copies of the Chart are available through National Union Distributors, free of charge to recognized universities, colleges and Signal Corps instruction centers or at \$1.00 each to individuals outside of the recognized institutions conducting fully accredited radio courses.

RADIO TUBES

We have "HARD-TO-GET" and "HARD-TO-FIND" Tubes available and coming in every day. Over 100 different tube numbers. Join our list of preferred customers by writing for those tubes you've been trying to obtain. Tubes for Ray Guns, Phonographs, and all types of coin-operated machines.

All Numbers Are Subject to Prior Sale! NET PRICES.

0Z4	\$1.65	6V6GT	\$1.15
1Q5GT	1.65	6Z4/84	1.10
2A3	2.00	7A8	1.35
3Q5GT	1.65	7B7	1.35
5Y3/GT75	7F7	1.65
6A7	1.00	83	1.35
6A8	1.35	84/6Z4	1.10
6C5	1.15	12SK7GT	1.10
6D6	1.00	12SQ7	1.00
6F6	1.15	12SQ7GT	1.10
6H6/GT	1.15	24A90
6Q7/GT90	25L6GT	1.15
6J595	2675
6J5GT95	2770
7695	35/51	1.00
7795	3790
7890	4290
6K7G	1.15	43	1.10
6N7/GT	1.65	50L6GT	1.10
6Q7/GT90	5685
6SK7	1.05	5795
6SQ7	1.05	117Z6/GT	1.65
6SQ7GT	1.15		

We Have Many Other Tube Numbers! Every order subject to prior sale. WPB LIMITATION ORDER No. L265 makes "Supplier's Certificate" mandatory with each order. ALL SHIPMENTS EXPRESS C.O.D. DO NOT SEND CHECK OR MONEY ORDER. ONLY MAIL ORDER BUSINESS ACCEPTED!

Chicago Novelty Company, Inc.

1348 Newport Avenue Chicago 13, Ill.

GLASS DRILLING AIDE

For those who have accurate, careful and rapid drilling in glass to perform, as in the optical trade—a new product has been developed, according to the manufacturer, E. Karelson, Inc., designers and producers of Diamond Cutting Tools. It is known as Sinszine.

It has a property that assures rapid, smooth cutting; another which lubricates and gives greater life to the Tool; a third that is a cooling agent for the Tool; and a fourth that prevents smears or greasy deposits. By means of a cloth, any glass to which Sinszine has been subjected, can be easily and quickly wiped off, leaving a brilliant luster—like a diamond. It is put up

PHONO-NEEDLE COUNTER CARD

Aero Needle Company, 737 North Michigan Ave., Chicago, is offering a new counter card to the trade featuring the Aeropoint "111" long-life phonograph needle.

The card contains a "baker's dozen"—13 attractively packaged needles instead of the usual 12—giving the dealer the advantage of an extra sale



per card. The display is done in four colors with a toned border in three dimensions to give it depth.

Aeropoint phonograph needles incorporate the exclusive shock-absorbing curved spring design.

Mfrs.' Lit.
(Continued from page 46)

Electric Company. In the booklet, simplified circuit diagrams are used liberally in explaining the fundamentals of the many types of electronic controls available to meet the exacting requirements of individual resistance welding processes and jobs.

Titles of the six articles reproduced in the booklet are: Electronic Welding Control; Seam and Pulsation Welding Controls; Special Welding Controls; Timers for Welding Control; Energy Storage Welding Controls; and Servicing Resistance Welding Controls.

A pictorial presentation of all types of electronic controls for resistance welding follows the article. Also portrayed are the many electric accessories *G. E.* has available for resistance welding processes, including the electrode pressure gage, the magnetic oscilloscope, cable, capacitors, motors, air circuit breakers and the pointer-stop ammeter.

This booklet is available upon a request for GET-1170, to the *General Electric Company*, Schenectady, New York.

MYCALEX BOOKLET

An eleven-page publication describing properties, advantages and applications of *G. E. mycalex* has been published by the Specialty Division of the *General Electric Company's* Electronics Department at Schenectady, New York. This booklet is available on request.

G. E. mycalex is a material made from mineral ingredients to meet exacting high-frequency insulation requirements. It is used extensively as an insulator in various types of electrical apparatus, particularly in radio, industrial control and heating equipment, and is produced in plates, rods, strips and disks from which parts are machined to finished shapes. It also can be compression-minded into simple shapes with and without metal inserts.

ELECTRONICS IN INDUSTRY

A clear-cut exposition of the practical part electronics is playing in various industrial fields is graphically presented in a 44-page booklet just released by the *RCA Victor Division of Radio Corporation of America*. Profusely illustrated in color, and written in non-technical language, this booklet, "Electronics in Industry," is being made available to business executives, manufacturers, and industrialists in whose fields the science of electronics may find applications.

The plainly-worded text and four-color illustrations dispel the mystery often associated with electronics by showing the workings of practical electronic devices now in operation in numerous fields of industry, government, education, and entertainment.

RCA electronic devices are shown improving products, making new products possible, eliminating safety hazards, and saving time, space, manpower, and costs in such familiar industrial operations as molding, soldering, localized hardening of metals, paint baking, riveting, gluing wooden veneers, and seaming fabrics.

Anyone who is eligible for one of these booklets should write to *RCA Victor Division of Radio Corporation of America*, Camden, N. J.

PILOT LIGHT ASSEMBLIES

Pilot Light Assemblies for use in every conceivable electrical, electronic, radio, aircraft, or industrial application, are described in the new *Dialco* catalog.

All *Dialco* Assemblies must meet three tests: Exacting engineering standards; 100% practicability; attractive appearance. Made as small as possible, the units enable manufacturers of complete equipment to use standard available Tungsten, Mazda, and Neon lamps.

To obtain a copy of this catalog, write directly to the *Dial Light Co. of America, Inc.*, 90 West Street, New York 6, N. Y.

DRY BATTERIES

The complete story of the development and uses of dry batteries has been published in a 48-page booklet that has attracted much attention for its readable and authentic text. It is now used by the Navy, Coast Guard and Marine Corps Training Divisions, as well as many colleges and other educational institutions.

"The Inside Story of Dry Batteries: A Guide for Students," is the title of this booklet. It has been prepared by scientists of *National Carbon Company, Inc.*, the country's oldest and largest dry battery manufacturer, and takes the reader from Alessandro Volta's discovery of the electro-chemical principle, in 1798, to the efficient units of today.

Readers who would like to have a free copy should write to the *National Carbon Company, Inc.*, 30 East 42nd Street, New York 17, New York.

FLUXINE CHART

Anyone interested in welding, brazing or silver soldering will find considerable use for the new *Krembs Fluxine Chart* . . . a handy key to finding the best flux to use in connection with a host of metal-joining jobs.

The Chart comes in bulletin form, is easy to use and is handy for reference. It gives a list of all the common metals and alloys—and many of the rarer ones—and recommends the most satisfactory flux to use when joining them by different processes. It is sponsored by an organization of welding and brazing consulting engineers, recognized as authorities in their field.

Men engaged in metal-working may obtain a complimentary copy of this

**Electronics
RADIO
ENGINEERING**

NEW COURSES FOR MODERN NEEDS

RADIONICS, the science of electronic applications, is widening its horizon hour by hour. There's a secure future in this field for YOU—provided you put **OUR TRAINING ON YOUR must list NOW.**

Needed at once are specialists in **Radio, Police Radio, Aviation Radio, Broadcasting, Television, Frequency Modulation, High Frequency Broadcasting, and Commercial Radio Telegraph.** That need will continue.

Our school is co-educational. It offers to women as well as men streamlined elementary and advanced courses for **Radio Servicemen, Radio Engineering Assistants, Radio Test and Maintenance men.** The work is thorough, practical, void of frills. The courses are approved by **State Vocational Departments, Major Airlines, State Police Systems, Radio manufacturers, and hundreds of Broadcasting Stations.**

Credit is given for Army radio courses and experience toward any of our courses. High school graduation or its equivalent necessary for advanced courses. Tuition at pre-war levels. Send for catalog today.

MAIL THIS COUPON NOW!

VALPARAISO TECHNICAL INSTITUTE,
Dept. R., VALPARAISO, Ind.

NAME.....

P. O. ADDRESS.....AGE.....

CITY AND STATE.....

CATALOG REQUEST—RADIO NEWS

2 IMPORTANT RADIO BOOKS

BASIC RADIO

JUST OUT!

By **G. L. Boltz**
Well-known British Authority

Covers the many principles of radio and gives the basic knowledge you need to study to go on to advanced work. Clarifies each essential idea by describing simple experiments and pointing out the facts.

CONTENTS: Fundamental ideas and definitions, Ohm's Law, Magnetism and Electromagnetism, Induction, Condensers, Alternating Current, Uses of Inductance and Capacitance, Waves, Tubes, Use of Tubes—(1) Oscillators, Transmission of Oscillations, (2) Detection, (3) R. F. Amplification, (4) A. F. Amplification, Receivers, Aerials and Feeders. **272 Pages, 166 illus., \$2.25.**

AERONAUTIC RADIO

by **M. F. Eddy, Lieut. U. S. Navy, Ret'd.**

A manual for Operators, Pilots, and Radio Mechanics. Follows requirements of the F.C.C. and C.A.A. and actual approved usage such as course guidance and instrument landing. Thoroughly covers the theoretical part of the aviation radio operator's license examination. Helps to acquire quickly skill in operation of radio equipment and understand instructions.

502 Pages, 198 Illustrations, \$4.50

THE RONALD PRESS COMPANY
Dept. M902 15 East 26th St., New York 10, N. Y.

Please send me books checked—

BASIC RADIO, Boltz..... \$2.25

AERONAUTIC RADIO, Eddy..... 4.50

On receipt I will pay postman cost plus few cents C. O. D. charge. If not entirely satisfied, I may return them within 5 days. (Sent postpaid if you remit with order. Same Guarantee.)

Name.....

Home Address.....

City & State.....

Check here for complete Aeronautics' Book catalog.

SOME ENGINEERS WE DON'T WANT AT NATIONAL UNION



Let's make it plain. There are a lot of engineers WE DON'T WANT. We have an outstanding group of engineering specialists who are GOING PLACES. They're thinkers, doers, practical dreamers. We're proud of them. WE DO WANT more engineers to join them but they have to be fellows who measure up. If you're not just trying to hit a high spot today. If you want to get into the exciting war work we're doing now and ride along on our great peace time electronic tube band wagon — THIS IS YOUR BIG OPPORTUNITY. We are adding to our staff engineers who specialize in

ELECTRONIC TUBES
PRODUCTION
DEVELOPMENT
MEASUREMENTS
PHYSICS
ELECTRICITY
TRANSMITTING TUBES.

Our laboratories in Newark, N. J., offer ideal working conditions. We prefer that you have a degree in electrical engineering, physics, chemistry or mathematics—your experience, however, may be sufficient.

Why don't you find out whether you're one of the engineers National Union DOES WANT. Write and tell us about yourself or Phone HUmboldt 2-5252, Ext. 72, for appointment.



**NATIONAL UNION RADIO
CORPORATION**

50 Spring Street, Newark, 2, N. J.

★ INDUSTRIAL ★ MAN-POWER BUREAU

ENGINEERS

CHECK WHAT WE HAVE TO OFFER

We may be a little different. We feel that a job should offer more than a high salary. Our philosophy is that a job should be as comfortable and reassuring as a fireside slipper. Dream to the limit of your imagination. Make use of all your talents to improve your position and pay. Raise hell if you think you're right. That's our story, and here's what we're looking for:

- Engineers with Amplifier experience
- Radio Engineers with mechanical ingenuity
- Engineers with a knack for Audio design
- Engineers who prefer RF problems
- Engineers with electro-physical apparatus design background

Our company is as old as radio itself, with a diversified background and a wide range of techniques in radio and electronics. The Jobs we offer aren't "opportunistic" propositions. They provide permanent berths for men of ability and vision. If you like our philosophy, and have the "know-how" to fill our requirements, let us hear from you. Our associates know of this ad.

Box 334, % Radio News
540 N. Michigan Ave., Chicago 11, Ill.

ESTABLISHED MANUFACTURER'S AGENT

Wanted By

West Coast Manufacturer covering New York City, Eastern Pennsylvania including Philadelphia, New England States, Maryland, Virginia, and New Jersey, who is well acquainted with Radio Parts Distributors, Philadelphia Signal Corps Procurement District, Manufacturers of Electronic equipment; excellent possibilities for Hard Working, Conscientious man, during and after the war. Write full details regarding lines carried and territory covered to Box No. 332 Radio News, 270 Madison Avenue, New York 16, N. Y.

WANTED!

Experienced Designer on small electric motors. Must be A-1. Submit full qualifications.

HARVEY MACHINE CO. INC.
6200 Avalon Blvd., Los Angeles, Calif.

WANTED ENGINEERS— TECHNICIANS FOR THE FAIRCHILD AVIATION CORP.

This long established instrument company now has positions open in the engineering department, for engineers, laboratory technicians and laboratory assistants for development and production in connection with war work. Positions are open in both senior and junior grades. Men experienced in general electronics or any phase of radio including ultra-high frequencies, production or developments will be considered. Salary in keeping with experience and background.

These are unusual opportunities for capable people interested in their present and post war future. Men who are qualified but not engaged at their highest skills and those not engaged in essential war work should apply. Reply by mail giving full details including age, education, experience and availability.

Write to

OFFICE OF CHIEF ENGINEER
**FAIRCHILD
AVIATION CORP.**
475 10 Ave., N. Y. 18, N. Y.

TECHNICAL WRITERS WANTED

Engineers and physicists who have had experience in (spare time) writing technical manuscripts on electronic design or applications including radio, television, facsimile, etc. Highest rates.

Reply Box 310, c/o RADIO NEWS
540 N. Michigan Ave., Chicago 11, Ill.

IMPORTANT TO ENGINEERS

We are compiling a register of Technicians and Electrical Engineers experienced in the manufacture and design of fractional horsepower electric motors—AC and DC—and electronic gadgetry. In establishing contacts and relationships we hope mutual benefits can be reached. We wish to lay our plans now for additions to our staff for post-war positions which can be filled now or later. All correspondence held in strict confidence.

THE ALLIANCE MANUFACTURING CO.
ALLIANCE, OHIO

"This section is designed to help the radio industry obtain trained, experienced, technical men to facilitate vital war production. Before applying for any of these positions consult your local United States Employment Service office to determine War Manpower Commission regulations concerning the changing of jobs. If you are already employed in war work at your highest skill, stick to your present job."

WESTERN ELECTRIC CO.

In PEACE

Source of supply for the
Bell System

In WAR

Arsenal of communication
equipment

wants

RADIO ENGINEERS

For Design of
Radio Test Sets

also

TESTERS

To do inspection and testing of
Radio Equipment

RELEASE STATEMENT AND U.S.E.S.
CONSENT NEEDED

Write or apply in person to:

C. R. L.
EMPLOYMENT DEPARTMENT

100 Central Ave.
Kearny, N. J.

WANTED

Radio Engineer For Important War and Postwar Work

Well established company located in Kansas City, Missouri, has fine opportunity for Radio Engineer with ability to design circuits for piezo-electric crystals. Must have knowledge of crystal industry, constructive imagination, and drive. Firm anticipates rapid post-war expansion. In reply give full details of education, experience, and date available. Also indication of salary expected. Application held in strict confidence.

Crystal Products Co.

1519 McGee St.
KANSAS CITY, MO.

POSITIONS OPE.

Design Engineers
Field Installation
and
Maintenance Engineers
at

WESTINGHOUSE

For Field Service Work
with
Micro-Wave Equipment

Opportunity for Service
Outside the United States
If Desired.

Radio Engineers and Electrical Engineers acceptable for brief training course prior to field assignments.

No one employed at his highest skill in essential industry should apply.

Applicants living outside the Baltimore area must obtain a "Statement of Availability" from their nearest United States Employment Service office.

Apply in Person or by Letter to

RADIO DIVISION
WESTINGHOUSE ELECTRIC &
MANUFACTURING COMPANY
2519 Wilkins Avenue
Baltimore, Maryland

RADIO ENGINEERS

Men wanted with laboratory research and complete electrical or mechanical chassis design experience.

Trav-Ler Karenola Radio
& Television Corporation
1028-36 West Van Buren St.
CHICAGO 7, ILLINOIS

ENGINEERS

Electrical—Mechanical
Aeronautical

For design, production and application work on fractional horsepower motors and mechanical devices. Plant located in city of 20,000 population immediately adjacent to Dayton, Ohio. Apply by letter giving education and experience to,

LEAR AVIA, Inc., Piqua, Ohio
Engineering Personnel Dept.

Must comply with W.M.C. regulations

RADIO STATION TECHNICIANS

Male or Female

TRANSMITTING OR RECEIVING

For Point-to-Point International Radio-communications Stations in the United States and abroad.

Applicants possessing at least an F.C.C. Radiotelegraph Commercial License preferred.

Do not apply if utilizing full skill on other war work.

Apply weekdays except Saturdays, between 10 A.M. and 3 P.M., personnel dept., or write

R. C. A.

Communications, Inc.

66 Broad St., N. Y. C.

ENGINEERS

Junior, Semi-Senior and Senior

Wanted for production developmental work. Must have some experience as technician and background in theory. Interesting work. Good living conditions. Salary in keeping with experience and background. Write stating qualifications in full. Interview arranged promptly.

Write to: Personnel Department

SPRAGUE SPECIALTIES CO.

NORTH ADAMS, MASS.

Applicants will be engaged only in strict compliance with regulations of the War Manpower Commission.

ENGINEER WANTED

Radio and electric motors, design
and Electronic Products.

Box No. 335 c/o Radio News

Inter-Communication System



SAVE TIME—EFFORT—MONEY

Ideal for Radio Servicemen, Factories, Hospitals, Army Camps or Service Centers. Easy to install, operates on AC or DC current.

This unit provides two-way conversation between Master Station and up to 5 Remote Stations. From Master Station you can carry on a separate conversation with any one Remote Station. Remote Stations can call and communicate with the Master Unit.

Model No. 908A—Including: One Master Station, One Remote Station, 50 Feet wire cable.

\$34.95

Model No. 909—Extra remote station.

\$7.50

Additional wire per 100 feet.

\$2.75

Price
Notice: PRIORITY RATED ORDERS with rating of AA-5 or higher receive immediate shipment. Orders without priority rating acceptable, subject to WPB authorization.

SPECIALS

No. 14D—Dynamic speaker, 14", 800 ohms. Regular list price \$13.20. Only **\$4.95**

No. 12 UPM—Heavy duty 12" permanent magnet speaker. Only **\$14.95**

Write today for our new bulletin of radio component parts, cabinets, complete console radios and de luxe phonograph recorders.

Mutual Radio Products Company
2926 Shakespeare Avenue Chicago 47, Illinois

7 Days

Free Examination

PRACTICAL RADIO INFORMATION

Including Frequency Modulation—Television, etc. Inside Radio Information for all Servicemen—Aircraft Pilots, Students. AUDEL'S RADIO-MAN'S GUIDE contains 772 Pages, 400 Diagrams & Photos is complete—Gives Authentic Principles & Practices in Construction, Operation, Service & Repairs. Covers clearly and concisely Radio fundamentals—Ohm's Law—Physics of sound as related to radio science—Measuring instruments—Power supply—Resistors—Inductors—Condensers—Transformers and examples—Broadcasting stations—Radio Telephone—Receivers—Diagrams—Construction—Control systems—Loud speakers—Antenna systems—Auto Radio—Phonograph pickups—Public Address Systems—Aircraft & Marine Radio—Radio Compass—Beacons—Automatic Radio Alarms—Short Wave—Coil Calculations—Testing—Cathode ray oscillographs—Static Elimination—Trouble Pointers—Underwriter's standards—Units and tables—Frequency Modulation—REVIEW QUESTIONS & ANSWERS, Ready Reference Index.

\$4 COMPLETE • PAY ONLY \$1 A MO. Get this practical information in handy form for yourself—Fill in and MAIL COUPON TODAY

AUDEL, Publishers, 49 W. 23rd St., N.Y. Mail AUDEL'S NEW RADIO-MAN'S GUIDE for free examination. If O.K., I will send you \$1 in 7 days; first month \$1 monthly until \$4 is paid. Otherwise I will return it.

Name _____
Address _____
Occupation _____
Reference _____ RN

chart by writing on their company letterhead to *Krembs and Company*, 676 West Ohio Street, Chicago 10, Ill.

CANNON BATTERY CONNECTORS

Cannon Electric's first complete Bulletin on its line of Battery Connectors for aircraft, engines and general industrial uses has just been issued.

Twenty-four pages and cover illustrate and describe a variety of battery connectors used with battery parts for engine starting, for the quick disconnect of large storage batteries, general service batteries, and rack battery installations. Application photos and condensed data sheets are also included.

Of particular interest is the new quick disconnect battery plug and kit for use on batteries conforming to AN-W-B-141 specifications.

Copies will be sent free upon request. Write to Catalog Department, *Cannon Electric Development Company*, 3209 Humboldt Street, Los Angeles 31, Calif.

RADIO FREQUENCY LACQUER

A new and improved radio frequency lacquer with a remarkably low loss factor over a wide frequency range has recently been offered for various electronic applications by *Communication Products Company*, 744 Broad Street, Newark, N. J.

In a 24-page booklet, now ready for distribution, the uses of Q-Max A-27 Radio Frequency Lacquer are illustrated and described. The electrical and physical properties of Q-Max, as determined by careful laboratory tests, are recorded in a series of useful graphs and charts.

Illustrated graphically, for a wide frequency range, are the dielectric constant, power factor and loss factor, while data is included for dielectric strength, density, drying time, adhesion and other characteristics.

CABLE AND WIRE DATA

Cannon Electric Development Company, 3209 Humboldt Street, Los Angeles 31, California, has just published a 24-page loose-leaf booklet on Signal System, Cable and Wire Data for engineers, estimators, wiremen and the electrical industry in general.

Among the data will be found the following: standard telephone cable color code, interphone telephone cable, switchboard telephone cable, wire types used in telephone and signal installations, resistance of copper wire, carrying capacities of wires, etc.

The pages, 4x6½, are 3-hole punched to fit into standard data books. Copies will be sent free upon request.

PIN-UP BOOKLET FOR AIR CORPS

A new 3-color booklet, "How To Use Your Electrically Heated Flying Clothing," has been prepared and published by the Pioneer Products Division of the *General Electric Company* for the Materiel Command of

NEW! ALLIED'S Rapid R-F RESONANCE & COIL WINDING CALCULATOR

only 25¢
Simple! Easy to use! For fast accurate determination of resonance factors and coil winding data. Only 25¢ postpaid. No. 37-955.

ALLIED RADIO CORP.
833 W. Jackson, Dept. C1-C-4, Chicago 7

RADIO TECHNOLOGY

RCA RCA Institute offers an intensive two-year course of high standard embracing all phases of Radio and Television. Practical training with modern equipment. Also shorter specialized courses in Commercial Radio Operating, Radio and Television Servicing, and Aviation Communications. For Free Catalog write Dept. RN-44.

RCA INSTITUTES, Inc.
A Radio Corporation of America Service
75 Varick St., New York 13, N. Y.

Specify SAUERISEN
ACIDPROOF CEMENTS—COMPOUNDS FOR
Tanks, Sewers, Stacks, Floors
Technical cements for all purposes.
Send sketches or samples
Sauerisen Cements Company • Pittsburgh 15, Penna.

Radio Servicemen:
RADIO PARTS—TUBES
BARGAIN PRICES—NO PRIORITIES
I.F. Coils—456 kc. \$0.39
5 inch PM Speakers..... 1.29
G.T. Tube Shields..... .05
Write Today for Bargain Bulletin
RADIO DISTRIBUTING COMPANY
P.O. Box 497 — PASADENA 18, California

Guaranteed Rebuilt
VIBRATORS—\$1.00 ea.
Send old vibrator. For very prompt delivery, enclose remittance and return postage. We rebuild any kind of vibrator or relay. Send your old vibrator to
BEST VIBRATOR CO., Box 5802
Cleveland 1, Ohio

Correspondence Courses in
RADIO and ELECTRICAL ENGINEERING
ELECTRICAL ENGINEERING Get good electrical field. Prepare yourself at Low Cost. for secure future. Modern courses. So simplified anyone can understand quickly.
RADIO ENGINEERING Extra fine course in radio, public address, photo-electric work. Trains you to be super-service man, real vacuum-tube technician. Servicemen needed badly. Diploma on completion.
Send postcard or letter for Free LOW \$25 Either
Copies of school catalogs, full details, all about deferred pay- AS Course
ment plan, etc. SEND NOW!
LINCOLN ENGINEERING SCHOOL, Franklin Stn., Box 61-R 63
(Formerly at Lincoln, Neb.) WASHINGTON, D. C.

PRE-INDUCTION
for Civilians and those entering Military Service
New classes now starting for men and women
● Radio Operating ● Code
● Radio Servicing—Electronics
NEW YORK Y. M. C. A. SCHOOLS
7 West 63rd Street, New York City

COMMERCIAL RADIO INSTITUTE
A radio training center for twenty-three years. Resident Courses only.
Pre-Induction, Broadcast, Service and Radio Telegraphy fall classes now forming for the mid-year term beginning February 7, 1944. Literature upon request.
Dept. D, 38 W. Biddle St., Baltimore-1, Md.



Send for this FREE 52-page Book. It shows that "crack" operators rely on something besides practice to develop their high speeds and proficiency; it explains the "knack" of sound-curse and sound-consciousness—the secret of speedy sending and receiving. Once you acquire these mental processes, reading code becomes almost second nature to you! Just as the swing rhythm of a dance band becomes automatic to musician and dancer.



Champions endorse the Candler System. Is used in training Commercial Operators, Amateurs, and Radiotelegraph Specialists in Signal Corps, Navy, Marines, Coast Guard, Naval Reserve, Airlines. Wherever the fastest and most efficient operators are found, there you will find Candler trained men.

If you want s-p-e-e-d, if you have any difficulties in operating technique, if 40-50 and more w.p.m. seem fantastic speeds to you—send for this revealing book now. It's yours without cost or obligation. Simply send your name and address.

CANDLER SYSTEM CO.
P. O. Box 928 Dept. 2-C
Denver 1, Colorado, U. S. A.
121 Kingsway, London, England, W.C. 2.

LEARN CODE
the way you'll be using it



by SOUND

The best way to learn to read code is by listening to code. The best way to learn to send code is by hearing your own

sending repeated back to you. With the new All-Electric Master Teleplex Code Teaching Machine, you learn code the natural, easy, fascinating way. Only instrument ever produced which records your sending in visible dots and dashes—then SENDS BACK your own key work at any speed you desire. There are NO PERFORATIONS—NO INK Far superior to anything ever developed... a marvel of simplicity. That's why practically every school teaching code uses MASTER TELEPLEX. We furnish complete course, including the All-Electric Master Teleplex, give you personal instruction with a MONEY-BACK GUARANTEE—All at a surprisingly low cost. Write today for FREE catalog RN-6. No obligation.

TELEPLEX CO., 107 HUDSON ST., JERSEY CITY, N. J.



Basic electrical and radio theory in the simplest possible language, written especially for those without mathematical or technical training.

Dozens of complete how-to-build-it descriptions of many types of receiving, transmitting, and test equipment show practical applications. Hundreds of diagrams and large photographs.

Enlarged war-training chapters include: expanded basic principles, more test equipment which can be field-built, and mathematics for solving simple radio problems. Over 600 pages, durably clothbound, gold-stamped. From your favorite dealer, or from us, postpaid; please add any applicable taxes.

\$2.00 in Continental U.S.A. Elsewhere, \$2.25

EDITORS AND ENGINEERS
1420 North Highland Avenue, Los Angeles

the Army Air Forces, Wright Field, Dayton, Ohio.

The booklet is written in a light, non-technical style and is designed to instruct Air Force personnel in the correct operation of the F-2 type of the Army Air Forces' electrically-heated flying suit.

The art work consists of drawings placed in the copy in a layout designed to eliminate captions.

To obtain "flash" reader interest the cover drawing has a "pin-up" flavor and depicts two girls standing in the prop-wash of a plane, battling their high-flying skirts while a "Roger" looks on approvingly.

General Electric's electrically-heated flying suit is the "war-baby" of peacetime automatic blanket factory.

-30-

Book Review

(Continued from page 40)

Examples of problems which might be met by the designer are given throughout the book. Such subjects as selectivity, gain control, undesired feedback, hum, spurious beats, distortion, parasitic resonances, etc., are covered. Although special cases of fault finding are discussed in all chapters, a special chapter is devoted to the general problem of fault finding.

Calculations and formulas are given mainly to illustrate simple methods of computation. Complicated mathematics have been avoided and approximations suitable to the problem in hand have been made throughout the book.

SUCCESSFUL SOLDERING. by Louie S. Taylor. Published by McGraw-Hill Book Company, New York and London. 76 pages. Price \$1.00.

The process of soldering is used perhaps more often and in more kinds of trades and crafts than any other simple method of joining metals, and yet it is often performed incorrectly. This book treats the subject in a clear, concise, and understandable manner, and gives the necessary directions and instructions so that the least experienced person can learn to solder.

The book covers the fundamentals of the process, and then takes up in detail the various types of soldering coppers and solders, explaining the purpose and demonstrating the correct uses of each. It also takes up the special problems of soldering various metals, such as black iron, zinc, tin, stainless steel, copper, aluminum, pewter, britania metal, and lead, devoting a separate chapter for each.

Many clear illustrations are included to assist in understanding the text, and the information given will aid the experienced workman in choosing the right materials and methods for any soldering work he may encounter.

-30-

110-VOLTS AC from DIRECT CURRENT

with KATO KONVERTERS. Furnish standard 110-volt AC from 32, 110, or 220-volts DC. Good deliveries on sizes 350 through 1500 watts.

PIONEERS IN THE BUILDING OF SMALL ROTARY CONVERTERS

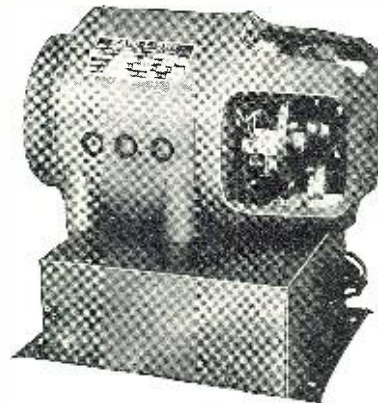

Katolight Rotary Konverter, 225 Watt

Good deliveries on 5, 7½, 15 and 25 KW AC generators. Mfg.'s DC generators, motor generators, frequency changers, high frequency generators.

Kato's entire production at present must be confined to orders with high priorities.

KATO ENGINEERING CO.
111 Rock Street. Mankato Minnesota

Order From **RADOLEK**

RADIO PARTS ELECTRONIC APPARATUS

SOUND SYSTEMS



Make Radolek your dependable buying source for everything in radio, sound and electronics. We can supply essential merchandise to repair any radio—tubes, condensers, resistors, controls, transformers, etc.—all at lowest prices.

Large Stocks: Radolek's large stocks assure the finest and most complete selections of all available items. Thousands of servicemen rely on Radolek for their entire requirements.

Fast Service. Streamlined handling of every order simplifies procurement problems and gives you fastest possible delivery. Whatever your need—for industry, the Armed Forces or Civilian replacement—ordering from Radolek saves time, effort and expense.

Get This Free Buying Guide



SEND TODAY!

RADOLEK CO., Dept. B-88.
601 W. Randolph St., Chicago, Ill.
Please send your FREE Buying Guide.

Name
Address
 DEALER SERVICEMAN SOUND ENG.

SAVE AT RADOLEK

COMPANY	AGENCY	PAGE NO.
Aerovox Corp.	Austin C. Lescarboursa & Staff	115
Alliance Mfg. Co.	Campbell-Sanford Adv. Co.	110
Allied Radio Corp.	Henry H. Teplitz	66, 112
American Condenser	C. Wendel Muench & Co.	96
American Phenolic Corp.	The Fensholt Co.	72, 73, 100
American Radio & Hardware Co., Inc.	Shappe-Wilkes, Inc.	15
Audel Publishers	Grant & Wadsworth	112
Best Vibrator Company		112
Bliley Electrical Co.	W. S. Hill Co.	84
Burstein Applebee Co.	Harry P. Bridge Co.	106
Candler System Co.	Galen E. Broyles Co.	113
Capitol Radio Engineering Institute	Henry J. Kaufman	98
Centralab	Custav Marx Adv. Agcy.	80
Chicago Novelty Co.	Sander Rodkin, Adv.	103
Commercial Radio Institute		112
Connecticut Telephone & Electric Div.	Wilson & Haight, Inc.	101
Consolidated Radio Products Co.	Burton Browne, Inc.	64
Crystal Products Co.	Burton Browne, Inc.	111
DeForest's Training, Inc.	MacDonald Cook Co.	91
DeJur Amsco Corp.	Shappe-Wilkes, Inc.	55
Delco Radio Division	Campbell-Ewald Co., Inc.	68
Detrola Corporation	Zimmer-Keller, Inc.	95
Echophone Radio Co.	Burton Browne, Inc.	5
Editors & Engineers		104, 113
Electronic Corporation of America	Shappe-Wilkes, Inc.	65
Electronic Laboratories, Inc.	Sidener and Van Riper, Inc.	67
Fada Radio & Electric Co., Inc.	Sternfield-Godley, Inc.	17
Fairchild Aviation Corp.	Commerce Agency, Inc.	110
Federal Telephone & Radio Corp.	Marschalk & Pratt Co.	9
General Electric Co.	N. W. Ayer & Son, Inc.	19
Gold Shield Products	Sternfield-Godley, Inc.	104
Gothard Mfg. Co.	Merchandising Advertisers	102
Greenlee Tool Co.	Howard H. Monk and Assc.	104
Guardian Electric Mfg. Co.	Kenedy & Co.	Third Cover
Hallicrafters	Burton Browne, Inc.	Back Cover
Hammarlund Mfg. Co., Inc.	Roeding & Arnold	20, 57
Harvey Machine Co.	West-Marquis, Inc.	110
Hytron Corp.	Henry A. Ludon	77
Illinois Condenser Co.		111
Indiana Technical College	N. W. Ayer & Son	104
International Resistance Co.	The Lavenson Bureau	60
Jensen Radio Mfg. Co.	Burton Browne, Inc.	16
Johnson, E. F. Co.	David, Inc.	85
Kato Engineering Co.		113
Kenyon Transformer Co.	Jasper, Lynch, & Fishel, Inc.	71
Lafayette Radio Corp.	Shappe-Wilkes, Inc.	69
Lake Radio Sales Co.		102
Lear Avia, Inc.	Arthur Kudner, Inc.	81, 111
Lincoln Engineering School	Buchanan-Thomas Adv. Agcy.	112
McGraw-Hill Book Co.		106
Mallory, P. R., & Co., Inc.	Aitkin-Kynett Co.	83
Meck, John Industries	Western Adv. Agcy., Inc.	76
Merit Coil & Transformer Corp.	Ross Llewellyn, Inc.	88
Millen, James, Mfg. Co., Inc.	James Millen, Inc.	10
Murdock, Wm. J., Co.	John A. Smith & Staff	70
Mutual Radio Products Co.		112
National Co., Inc.	Graydon Smith, Adv.	7
National Radio Institute	Van Sant Dugdale & Co.	3
National Schools	The Mayers Co.	105
National Union Radio Corp.	Sayre M. Ramsdell Assc.	93, 110
Nelson Co.	A. N. Baker Co.	104
New York YMCA Schools	Cecil & Presbrey, Inc.	112
Ohmite Mfg. Co.	Henry H. Teplitz	53
Onan & Sons, D. W.	Burton Browne, Inc.	100
Park Metalware Co.	Melvin F. Hall Adv. Agcy.	92
Pioneer Gen-E-Motor	Burton Browne, Inc.	74
Polymet Condenser	Sternfield-Godley, Inc.	104
Radio & Tech. Div. of Murray Hill Books	Harry P. Bridge Co.	62, 63
Radio Distributing Co.		112
Radio Receptor Co., Inc.	Shappe-Wilkes, Inc.	18
Radio Training Association of America		104
Radolek Co.	Turner Adv. Agcy.	113
Randolph Radio	Burton Browne, Inc.	90, 102
RCA	Kenyon & Eckhardt, Inc.	29
RCA Communications	Shappe-Wilkes, Inc.	111
RCA Institutes, Inc.		112
Rider, John F. Publisher, Inc.		78
Ronald Press Co.	Grant & Wadsworth, Inc.	109
Sauereisen Cements Co.		112
Shure Brothers	Henry H. Teplitz	79
Solar Mfg. Corp.	O. S. Tyson & Co.	11
Sprague Products Co.	Harry P. Bridge Co.	59, 111
Sprayberry Academy of Radio	Harry P. Bridge Co.	13
Standard Transformer	Burnet-Kuhn Adv. Co.	81
Stevens Walden, Inc.	Howard-Wesson Co.	12
Superior Instruments Co.	Loewy Adv. Agcy.	94
Supreme Publications	Henry H. Teplitz	97
Sylvania Electric Products, Inc.	Arthur Kudner, Inc.	8
Telegraph Apparatus	Burton Browne, Inc.	94
Telex Co.	Terrill Belknap Marsch Assc.	113
Thordarson Electric Mfg. Co.	Duane Wanamaker, Adv.	96
Tobe Deutschmann Corp.	Franklin Bruck Corp.	116
Trav-ler Karenola Radio & Television Corp.		111
Triplett Electrical Instrument Co.	Jones Frankel Co.	111
Tri-State College	Western Adv. Agcy.	6
Turner Co. The	Clern U. Steigmeyer	106
United Transformer Co.	W. D. Lyon Co.	56
Universal Microphone Co., Ltd.	Shappe-Wilkes, Inc.	Second Cover
Utah Radio Products Co.	Ralph L. Power	14
Vaco Products Co.	The Buchen Co.	59
Valparaiso Technical Institute	Duane Wanamaker, Adv.	102
Vaughan Cabinet Co.	Smith, Benson & McClure, Inc.	104, 109
Ward Leonard Electric Co.	Sander Rodkin, Adv.	94
Warwick Mfg. Co.	E. M. Freystadt	103
Western Electric Co.	Western Newspaper Union	87
Westinghouse Electric & Mfg. Co.	Deutsch & Shea	111
	Fuller & Smith & Ross, Inc.	79, 111

Classified

Rate 15c per word. Minimum, 10 words

CORRESPONDENCE COURSES

RADIO Communications courses qualifying for all Federal licenses. Home study and resident courses. American Radio Institute, 44 East 23rd St., New York, N. Y.

USED Correspondence Courses and Educational Books sold or rented. Inexpensive. Money-back guarantee. Write for Free Catalog listing 4000 bargains.—(Courses Bought.)—Lee Mountain, Piggah, Ala.

CORRESPONDENCE Courses and self-instruction books, slightly used. Sold. Rented. Exchanged. All subjects. Satisfaction guaranteed. Cash paid for used courses. Complete details and 84-page illustrated bargain catalog free. Write Nelson Company, 237. Chicago.

RADIO interference causes. What they are, where they come from and how to prevent them explained in new copyrighted booklet, Radio Listeners' Guide. Written in plain language by interference expert, fifteen years in the field. \$1.00 Postpaid. A. E. Rowe & Co., Inc., Dept. R, 660 Mission St., San Francisco 5, Calif.

PATENT ATTORNEYS

INVENTORS—Before disclosing your invention to any one send for Form "Evidence of Conception"; "Schedule of Government and Attorneys' Fees" and instructions. Sent free. Lancaster. Allwine & Rommel, 414 Bowen Building, Washington, D. C.

RADIO ENGINEERING

RADIO Engineering, Broadcasting, Aviation and Police Radio, Servicing, Marine Operating and Electronics taught thoroughly. Expenses low. Write for catalog. Valparaiso Technical Institute, Dept. N, Valparaiso, Ind.

WANTED

WANTED: Portable Home Recorder, new or used. Will pay cash. John J. Musser, Bowmansville, Pa.

WANTED to buy, all copies of Electrical Experimenter for year 1918. Edward Olson, 3521 W. Howe St., Seattle, Wash.

HELP WANTED

ELECTRONICS Engineer, \$4000 Bracket. Post-war opportunity with old established national manufacturing firm. Requires department head calibre scientist well experienced research and development electrically controlled mechanisms and radio apparatus. Rush credentials. Box 333, % Radio News.

MISCELLANEOUS

50L6, 35L6 and 12 series tubes repaired (60%). Quick service. 75c ea. Cullen Radio, 798 Third, San Bernardino, Calif.

PHOTO CREDITS

Page Numbers	Credits
34	Acme
12, 38, 39...	U. S. Army Signal Corps
44 (top)	National Film Board
44 (bottom), 45 (top)	General Electric
45 (bottom)	Westinghouse

Ammunition



VICTORY PAPER TUBULARS Aerovox Type 684V

AEROVOX CAT. NO.	A.S.A. SPEC. NO.	D.C. W.V.	CAPACITY M.F.D.	LIST PRICE
684V	VPC-2	600	.001	\$0.20
684V	VPC-3	600	.002	.20
684V	VPC-4	600	.005	.20
684V	VPC-5	600	.01	.20
684V	VPC-6	600	.02	.20
684V	VPC-7	600	.05	.25
684V	VPC-8	600	.1	.30
684V	VPC-9	600	.25	.45

VICTORY ELECTROLYTICS Aerovox Type PRSV

AEROVOX CAT. NO.	A.S.A. SPEC. NO.	D.C. W.V.	CAPACITY M.F.D.	LIST PRICE
PRSV	VEC-10	25	25	\$0.60
PRSV	VEC-2	50	10	.55
PRSV	VEC-3	150	20	.75
PRSV	VEC-4	150	20-20	1.30
PRSV	VEC-5	150	50	1.10
PRSV	VEC-6	250	20	1.00
PRSV	VEC-7	450	10	.85
PRSV	VEC-8	450	10-10	1.40
PRSV	VEC-9	450	40	1.75

for the HOME RADIO FRONT

• These are Victory Capacitors. Available in voltages and capacitance ratings selected to meet a wide range of servicing requirements. Indeed, these numbers, used singly or in groups, can service about 90% of the usual capacitor replacements, while much critical material and labor are being conserved for the urgent needs of our fighting men.

AEROVOX VICTORY PAPER CAPACITORS are simply certain selected values in the long-established Aerovox Type 684 tubular line. Millions already in daily use. Enviably performance records. Conservatively rated non-inductive vacuum-impregnated paper sections in extra-wax-sealed cartridges. Yellow-black-red varnished label jackets. They are just as good as they look.

AEROVOX VICTORY ELECTROLYTICS are selected values of well-known Aerovox Type PRSV Dandees. Again, millions already in daily use. Conservatively rated dry electrolytic sections in sturdy tubular housings. Extra-wax-sealed. Built for tough going.

For the duration... for dependable servicing... you can count on Aerovox Victory Capacitors: truly ammunition for the home radio front.

SEE OUR JOBBER... Consult him regarding your wartime capacitor requirements. He carries a stock of essential replacements for your regular servicing and maintenance needs. And for your more special needs, if they have a war significance, he can get unusual items on high priorities.



Capacitors

INDIVIDUALLY TESTED

AEROVOX CORPORATION, NEW BEDFORD, MASS., U. S. A. • SALES OFFICES IN ALL PRINCIPAL CITIES
Export: 100 VARICK ST., N. Y. C. • Cable: 'ARLAB' • In Canada: AEROVOX CANADA LTD., HAMILTON, ONT.

YESTERDAY... TODAY... Tomorrow

A record for long life has been earned by Tobe Capacitors through an almost complete absence of "returns". Equally notable has been Tobe's ability to master difficult specifications. The "DP" Molded Paper Condenser shown below is an example. The new American War Standards "specs" are tough ones to meet—but we meet them. Ask us for samples and judge for yourself.



SPECIFICATIONS "DP" MOLDED PAPER CONDENSERS

- CAPACITANCE.....001 to .04 MFD
- WORKING VOLTAGE.....See chart below
- SHUNT RESISTANCE.....Flash test 3 times rated DC working voltage
At 185° F— 1000 megohms or greater
At 72° F— 50000 megohms or greater
- WORKING TEMPERATURE RANGE.....Minus 50° F to plus 185° F
- OPERATING FREQUENCY RANGE.....Upper limit 40 megacycles
Q at one megacycle—average 20
- POWER FACTOR.....At 1000 cycles .004 to .006
- DIMENSIONS.....13/16" x 13/16" x 19/64"

Capacity in MMFD.	DC Working Voltage Rating	TOBE & AMERICAN WAR STANDARDS DESIGNATIONS	
		"A" Characteristic	"B"
1000	600—1500	CN35A102	CN35B102
1500	600—1500	CN35A152	CN35B152
2000	600—1500	CN35A202	CN35B202
2500	600—1250	CN35A252	CN35B252
3000	600—1000	CN35A302	CN35B302
4000	600—1000	CN35A402	CN35B402
5000	600— 800	CN35A502	CN35B502
6000	600— 800	CN35A602	CN35B602
7000	500— 700	CN35A702	CN35B702
8000	500— 700	CN35A802	CN35B802
10000	400— 600	CN35A103	CN35B103
20000	200— 300	CN35A203	CN35B203
30000	50— 150	CN35A303	CN35B303
40000	50— 100	CN35A403	CN35B403

EGYPTIAN OBELISK
Central Park, New York, dates from the 18th Dynasty (1600 BC) of King Thut-Mose, the Third.



A SMALL PART IN VICTORY TODAY — A BIG PART IN INDUSTRY TOMORROW

wherever a **tube** is used...

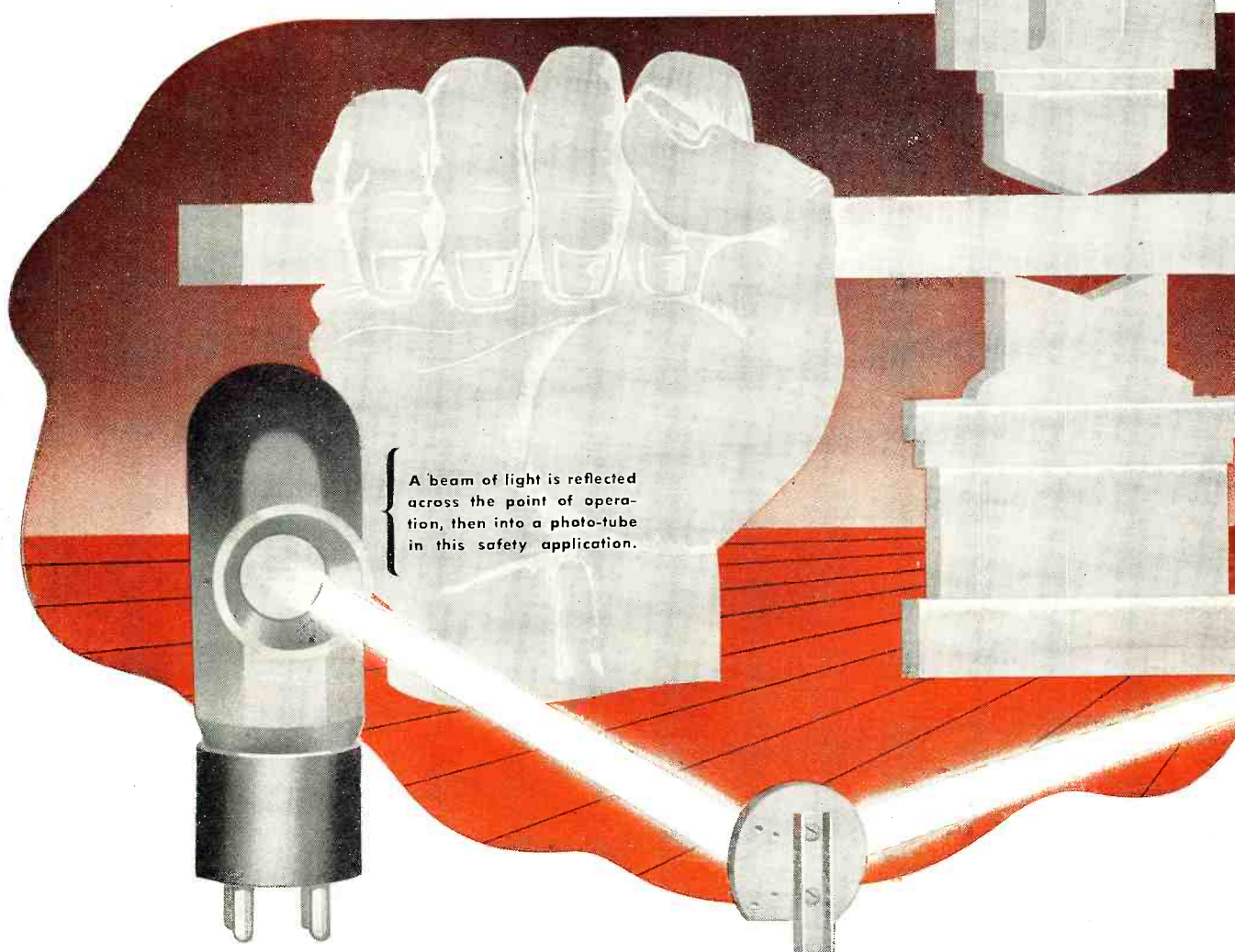

A beam of light is reflected across the point of operation, then into a photo-tube in this safety application.

THERE'S A JOB FOR

Relays BY GUARDIAN*

Where makeshift mechanical devices rudely thrust your workers' hands and fingers away from punching and forming dies, the electron tube in combination with a relay offers definite advantages for safer power press operations.

Instantly responsive, dependable and simple—a beam of light, if broken or modulated, actuates the electron tube; the relay breaks the circuit and locks the controls in the "off" position until the full light beam is restored. Typical of relays which may be used in conjunction with such a photo-tube safety application, is the Series 5 D.C. Relay by Guardian. In hundreds of other ways—especially in your postwar developments—wherever a tube is used there's usually a job for Relays by Guardian.

* Not limited to tube applications but used wherever automatic control is desired for making, breaking, or changing the characteristics of electric circuits.

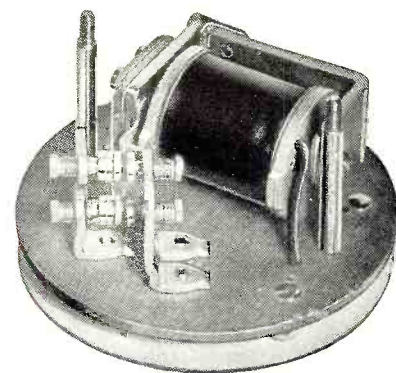

Series 5 D.C. Relay. Maximum switch capacity two normally open—two normally closed—or DPDT Contacts. Resistance range .01 up to 15,000 ohms. Send for bulletin 14.

GUARDIAN  **ELECTRIC**
1630-C W. WALNUT STREET CHICAGO 12, ILLINOIS

A COMPLETE LINE OF RELAYS SERVING AMERICAN WAR INDUSTRY

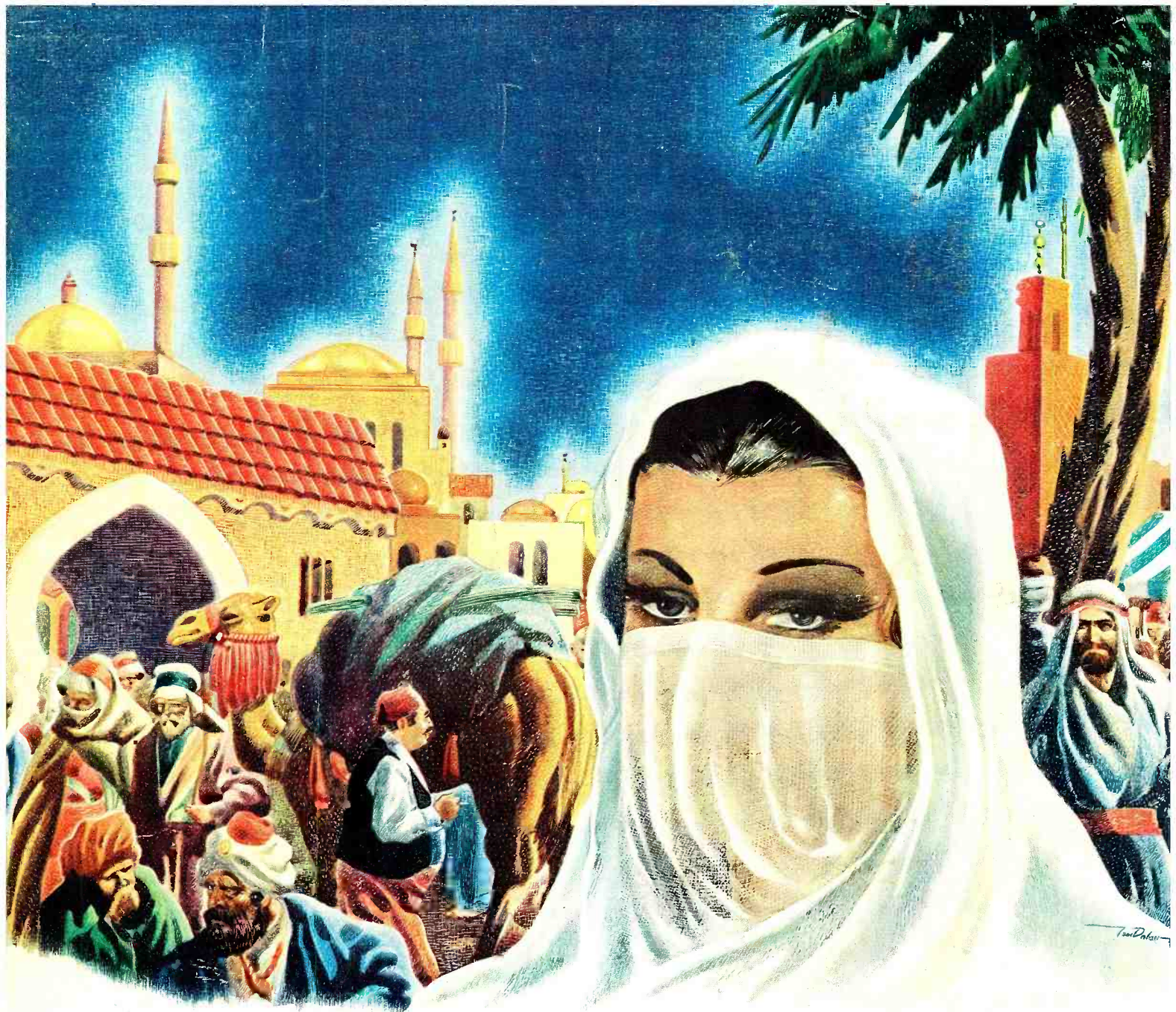

**HALLICRAFTERS IS NOT ONLY THE WORLD'S LARGEST
EXCLUSIVE MANUFACTURER OF SHORT WAVE
RADIO COMMUNICATIONS EQUIPMENT . . .**

. . . before the war they sold more short wave receivers than all other manufacturers in this field combined!

The United States entry into the war found Hallcrafters equipment immediately pressed into service with the Allied Nations all over the world and on all the seven seas . . . meeting wartime requirements altho originally designed for amateur use! Radio receivers and trans-

mitters are great weapons of war the same as any tank or plane. Evidence of the *big job* Hallcrafters is doing is the fact that they are *the 1st Exclusive Radio Manufacturer to receive the Army-Navy Production Award for the 3rd time.*

All the things *and more* that make Hallcrafters receivers and transmitters great weapons TODAY—will be embodied in the receiver Hallcrafters will build for you—TOMORROW!

BUY MORE BONDS!

hallicrafters RADIO



THE HALLICRAFTERS CO., MANUFACTURERS OF RADIO AND ELECTRONIC EQUIPMENT, CHICAGO 16, U. S. A.